

# Карданные передачи

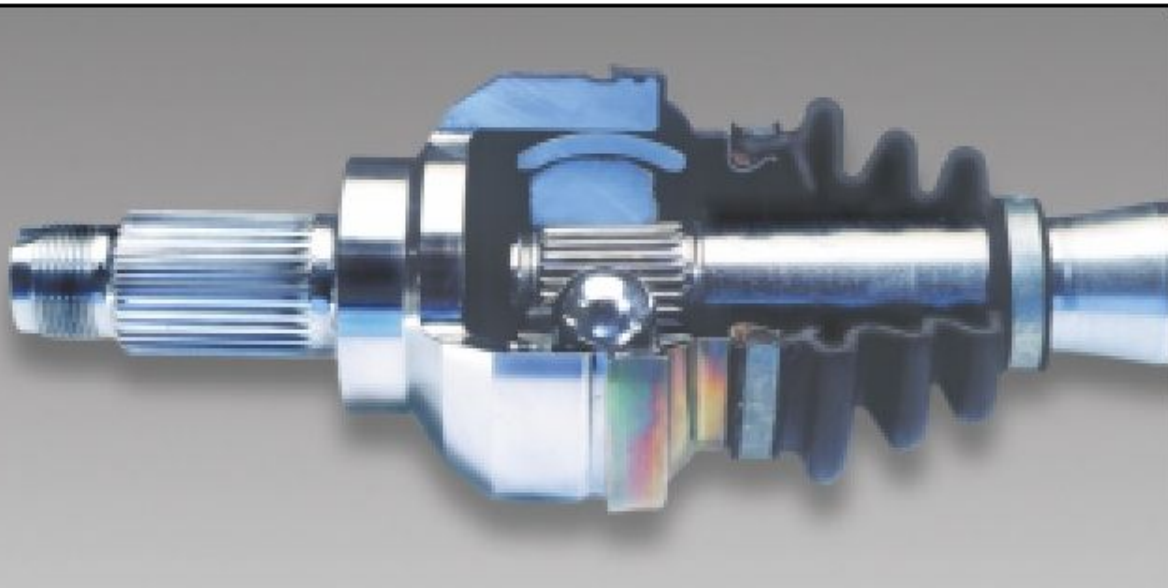

# Карданные передачи

- Предназначены для передачи крутящего момента от одного агрегата к другому, если оси их валов изменяют свое положение или не лежат на одной прямой.
- Требования
  - Передача крутящего момента при возможных в эксплуатации скоростях и углах между осями
  - Высокий к.п.д. при значительных углах между осями
  - Минимальные вибрации и шум
  - Отсутствие значительных осевых усилий и износов в компенсирующем узле

# Кинематика карданного шарнира

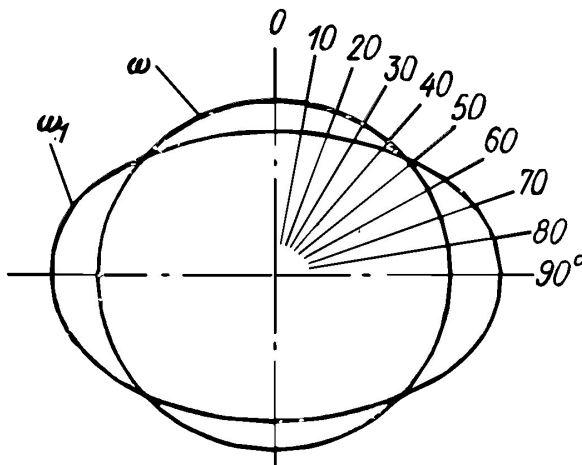
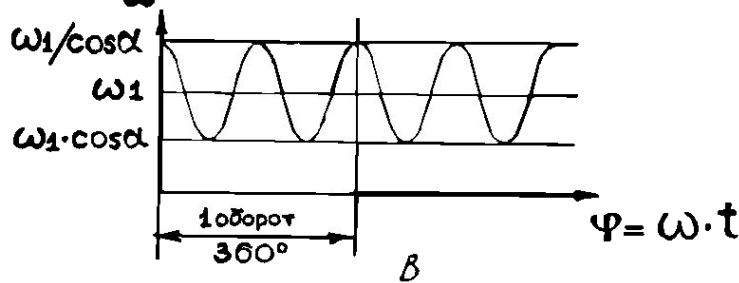
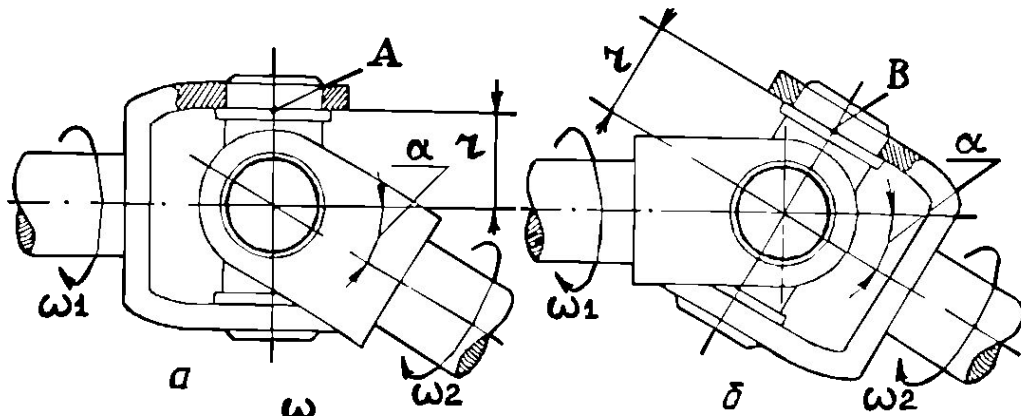

$$V_A = \omega_1 r = \omega_2 r \cos \alpha;$$

$$\omega_2 = \frac{\omega_1}{\cos \alpha};$$

$$V_B = \omega_2 r = \omega_1 r \cos \alpha;$$

$$\omega_2 = \omega_1 \cos \alpha;$$

$$\omega_1 \cos \alpha \leq \omega_2 \leq \frac{\omega_1}{\cos \alpha}$$

# Коэффициент неравномерности

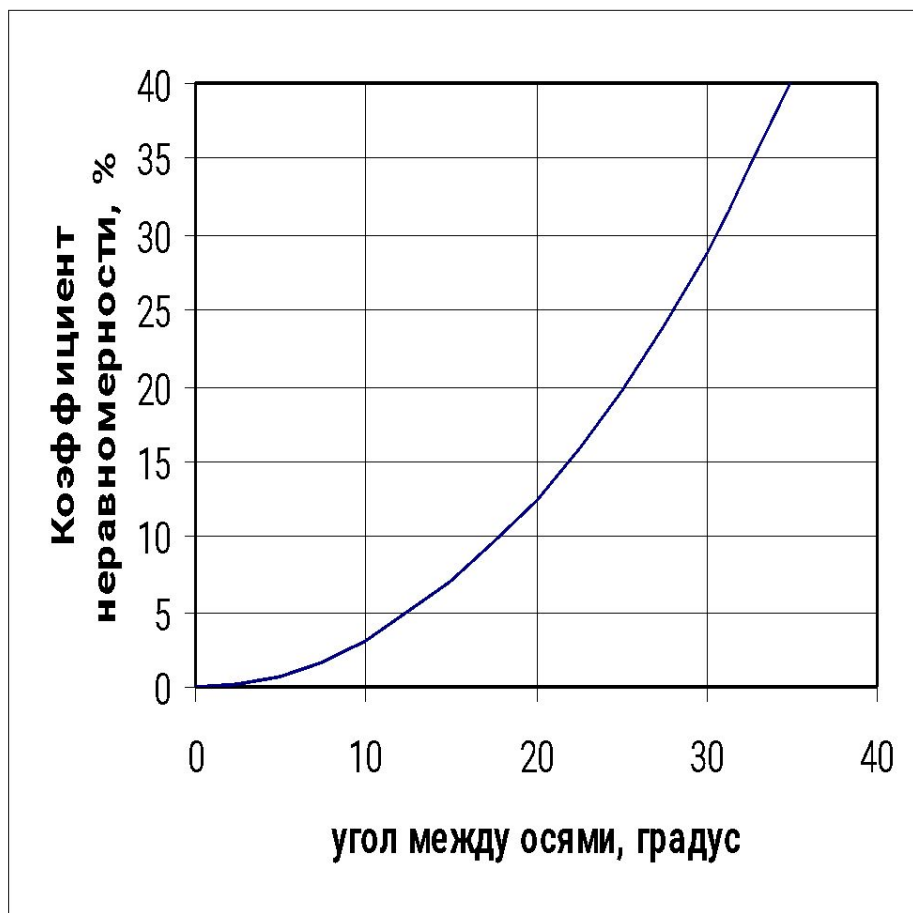

$$K_H = \frac{\omega_{2\max} - \omega_{2\min}}{\omega_1}$$

$$K_H = \sin \gamma \cdot \operatorname{tg} \gamma$$

# Схема сил (рабочий процесс)

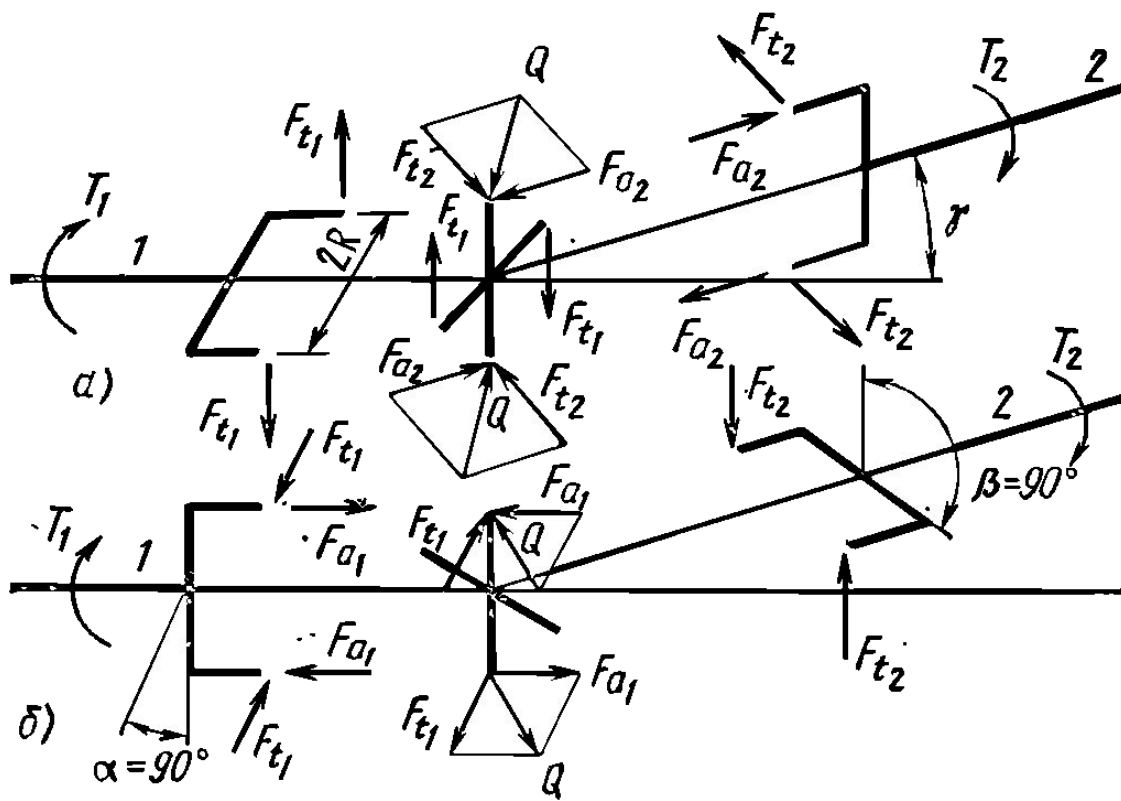

$$Q_{\max} = T_1 / (2R \cos \gamma);$$

$$F_{t2 \max} = T_1 / (2R);$$

$$F_{a1 \max} = (T_1 / 2R) \operatorname{tg} \gamma.$$

# Минимизация неравномерности вращения

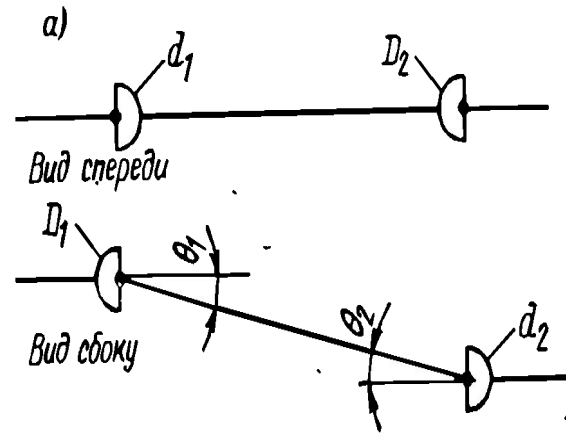
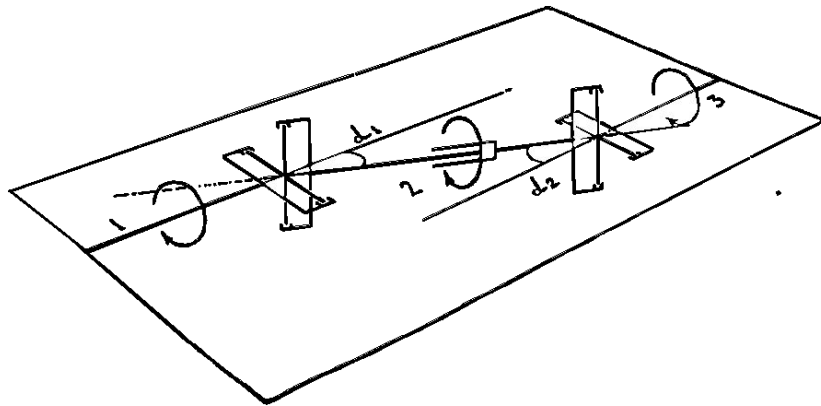
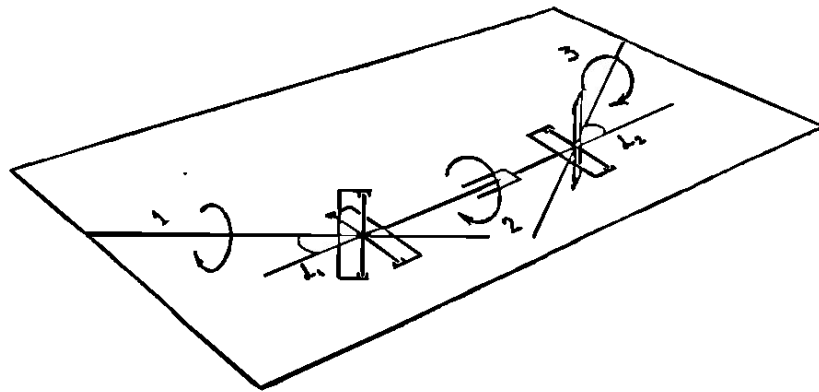

$$\theta_{рез} = \sqrt{\theta_1^2 - \theta_2^2}$$

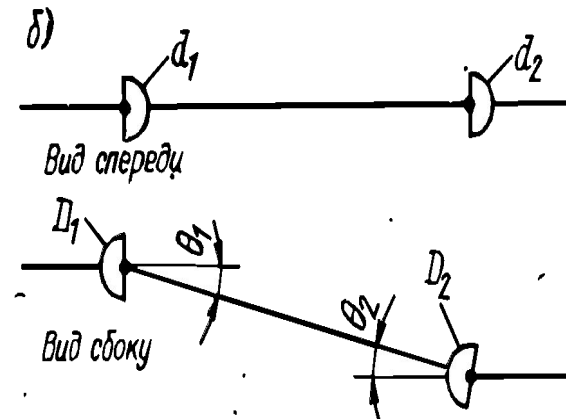

$$\theta_{рез} = \sqrt{\theta_1^2 + \theta_2^2}$$

# Детали шарнира - крестовина

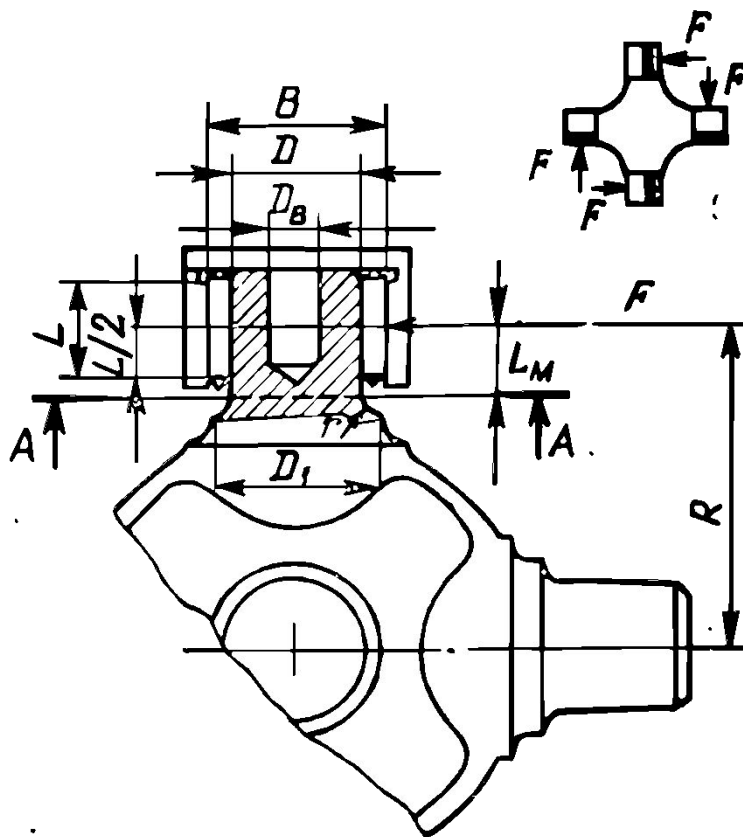

# Детали шарнира - подшипники

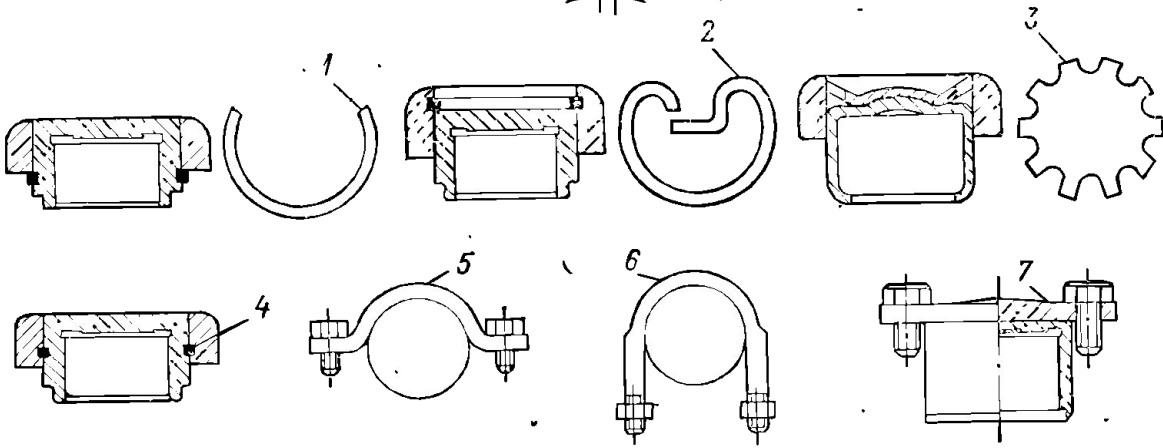
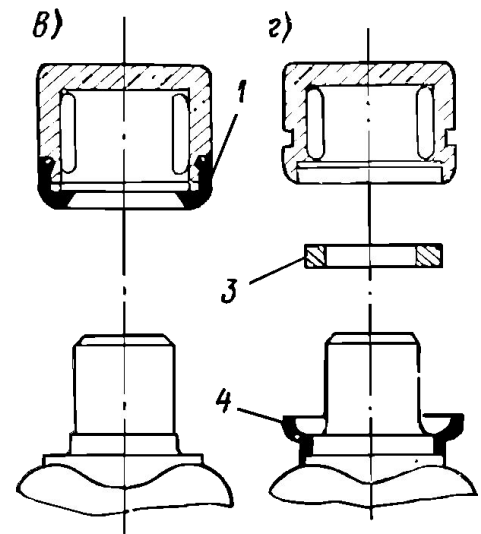
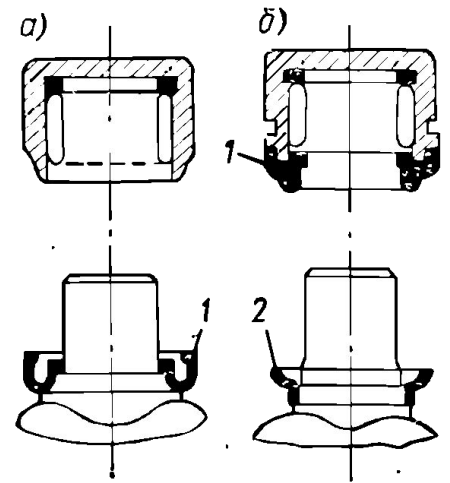
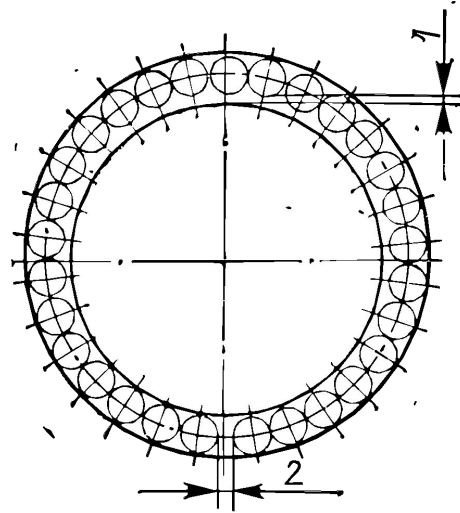



# Влияние жесткости вилки на работу элементов подшипника

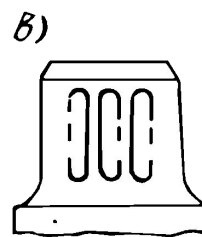
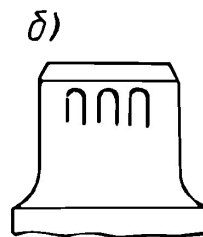
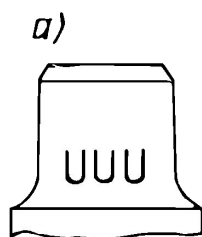
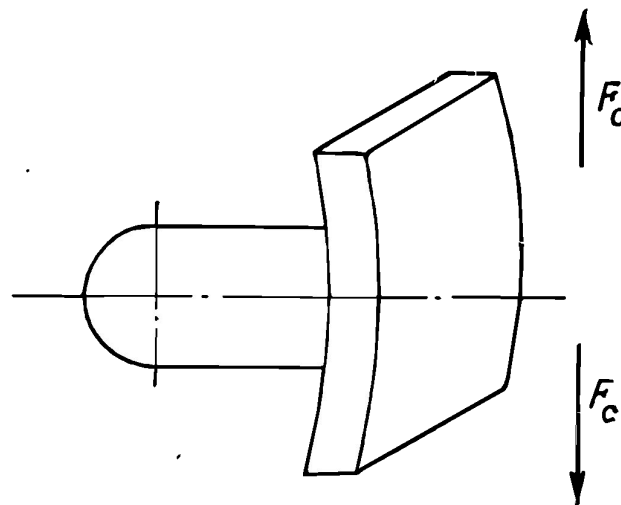
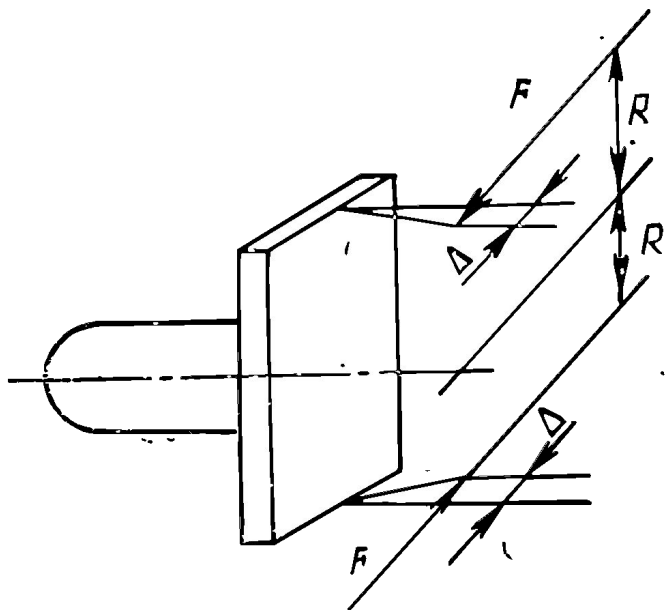

# Упругий карданный шарнир

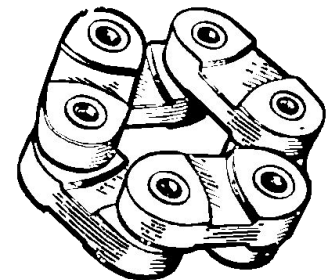
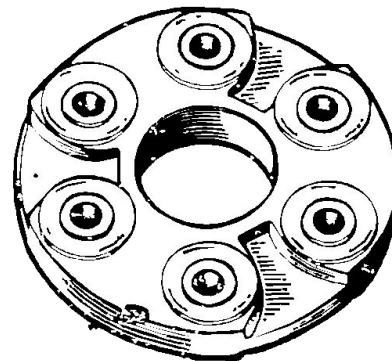
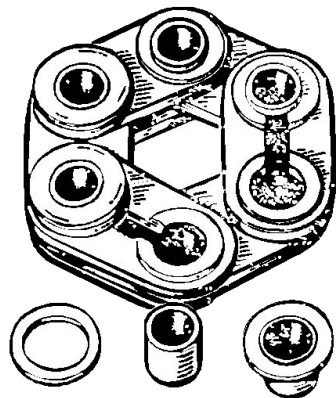
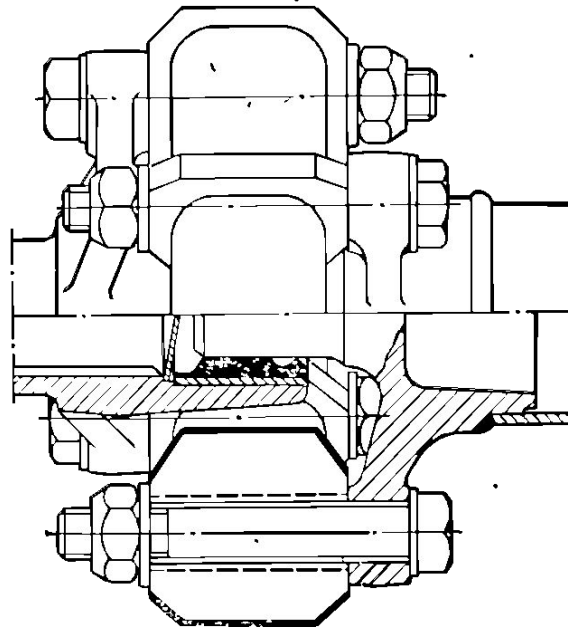
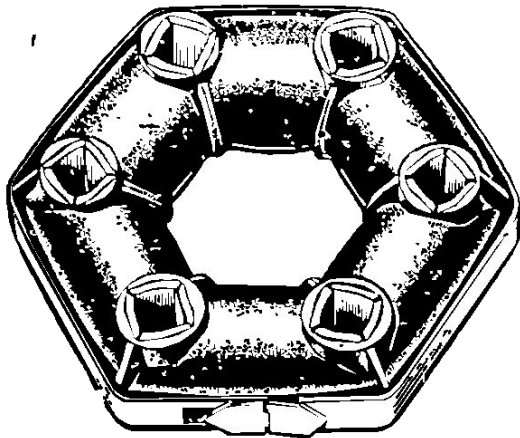

# Упругий карданный шарнир

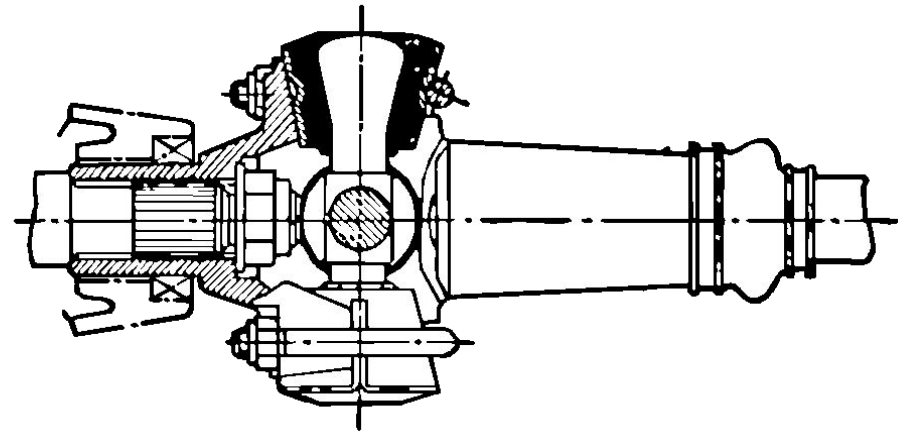
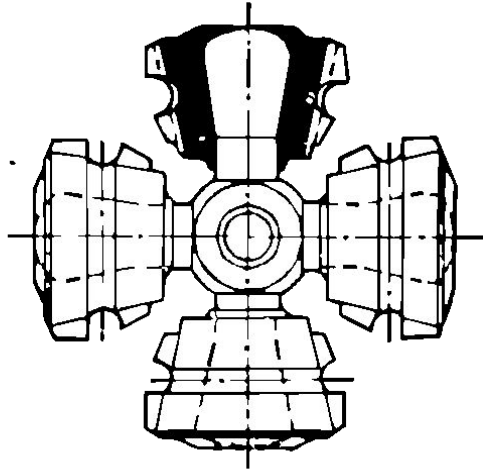
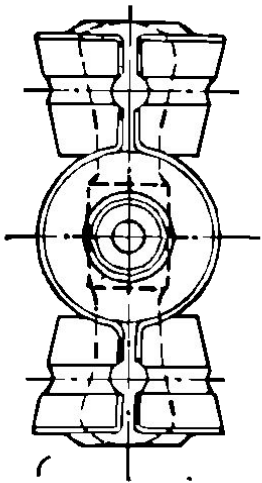

# Идея работы ШРУСа

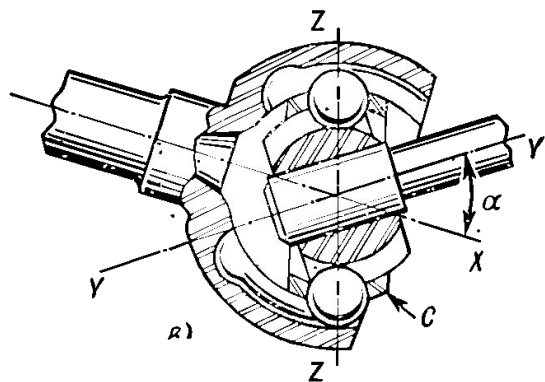
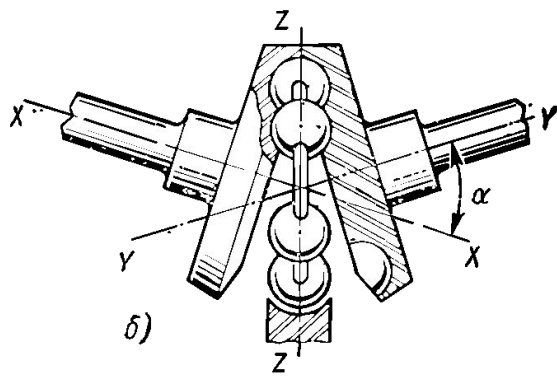
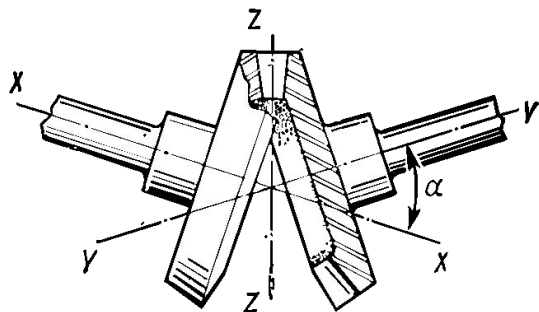

# Шарнир Рцеппа (Beerfield)

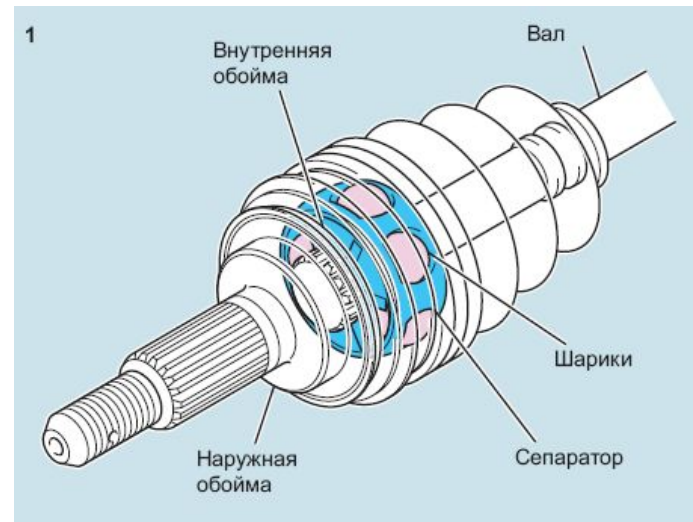
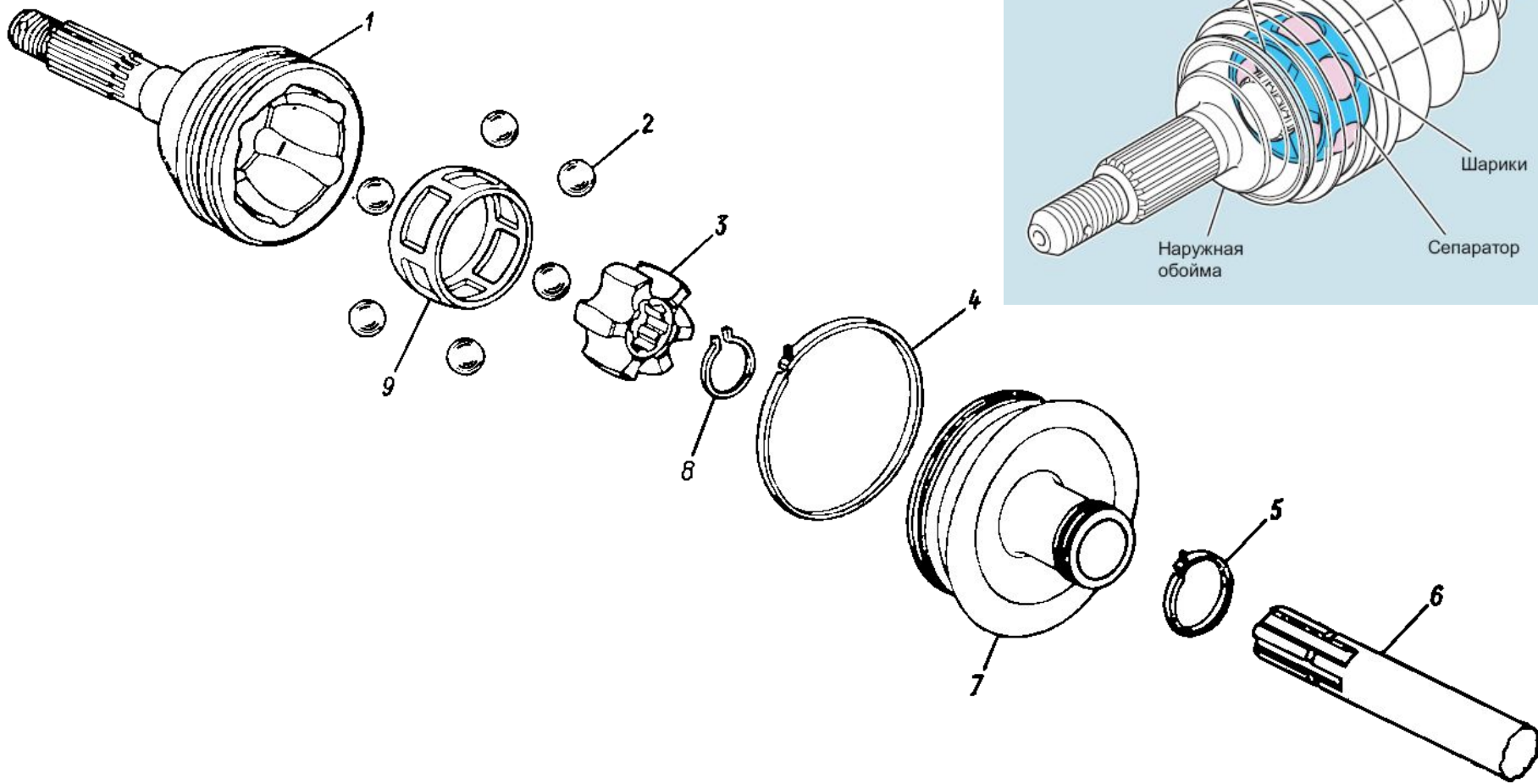

# Шарнир Рцеппа (Beerfield)

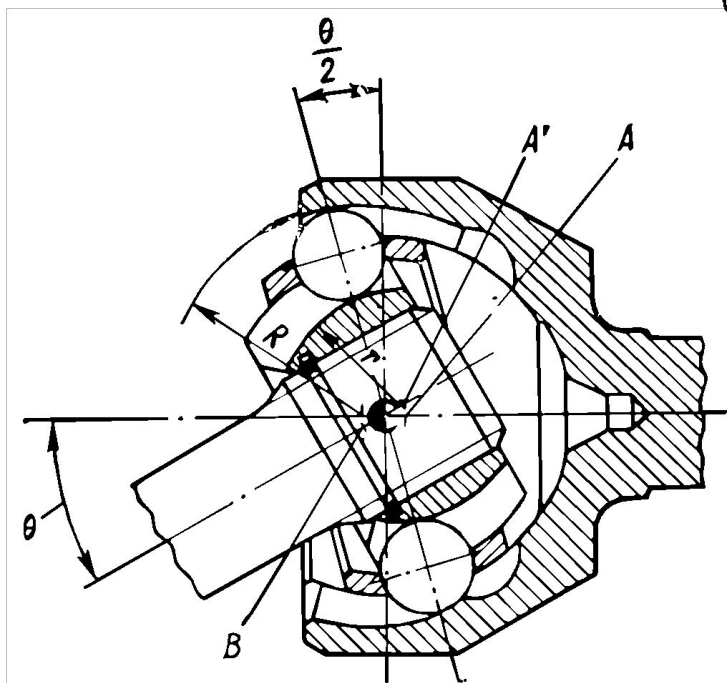
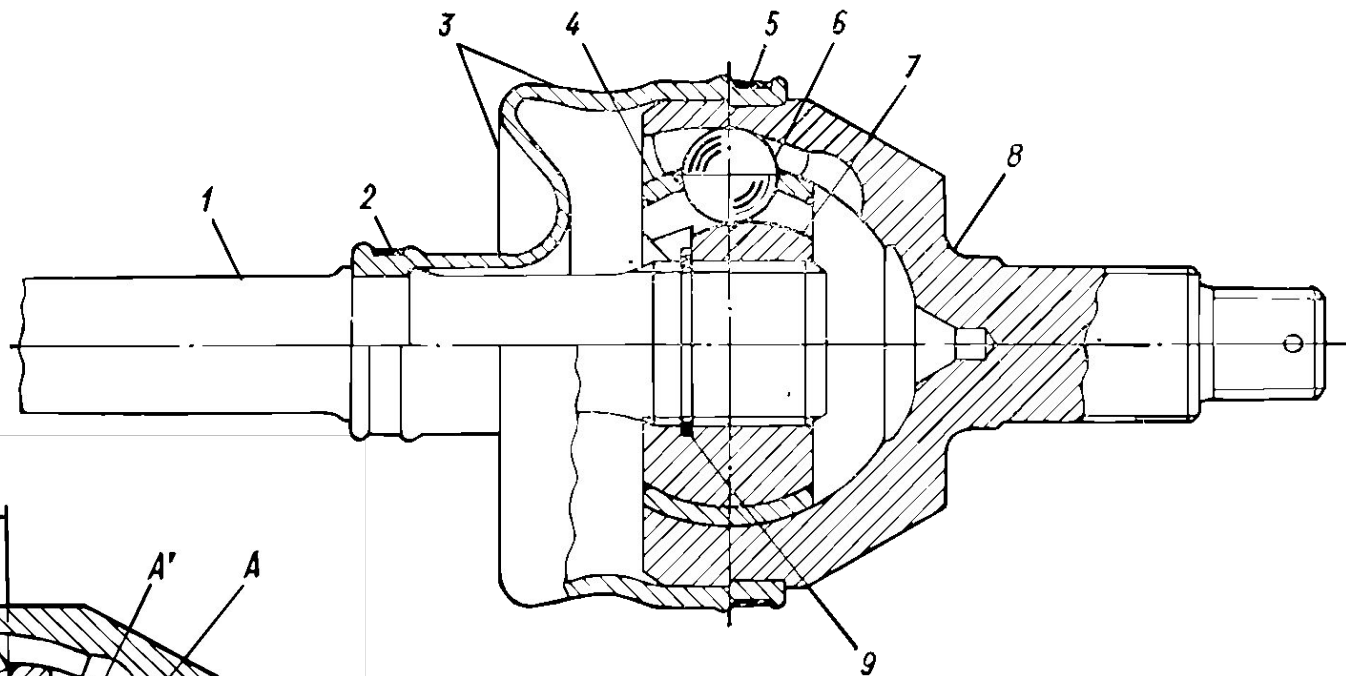

# Шарнир Рцеппа (Beerfield)

плавающего типа

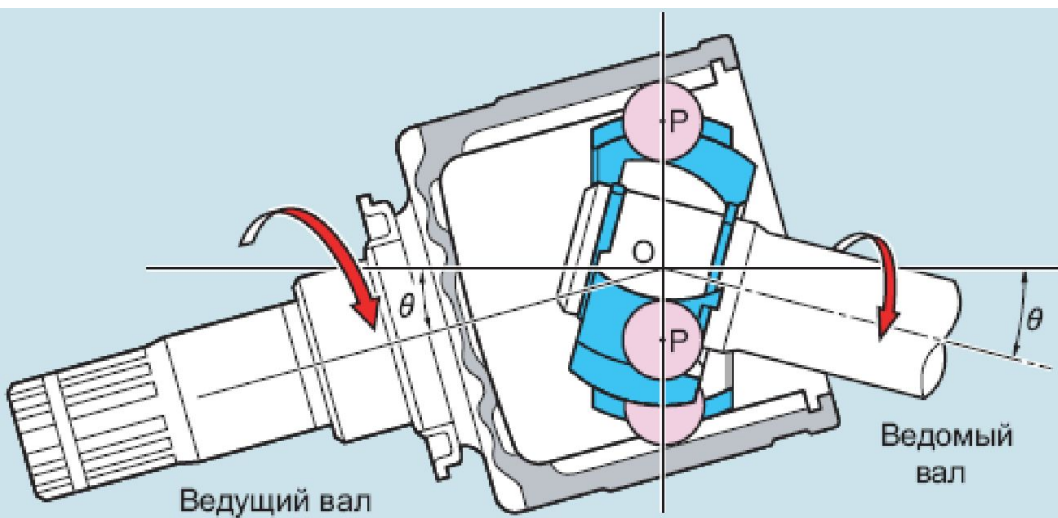
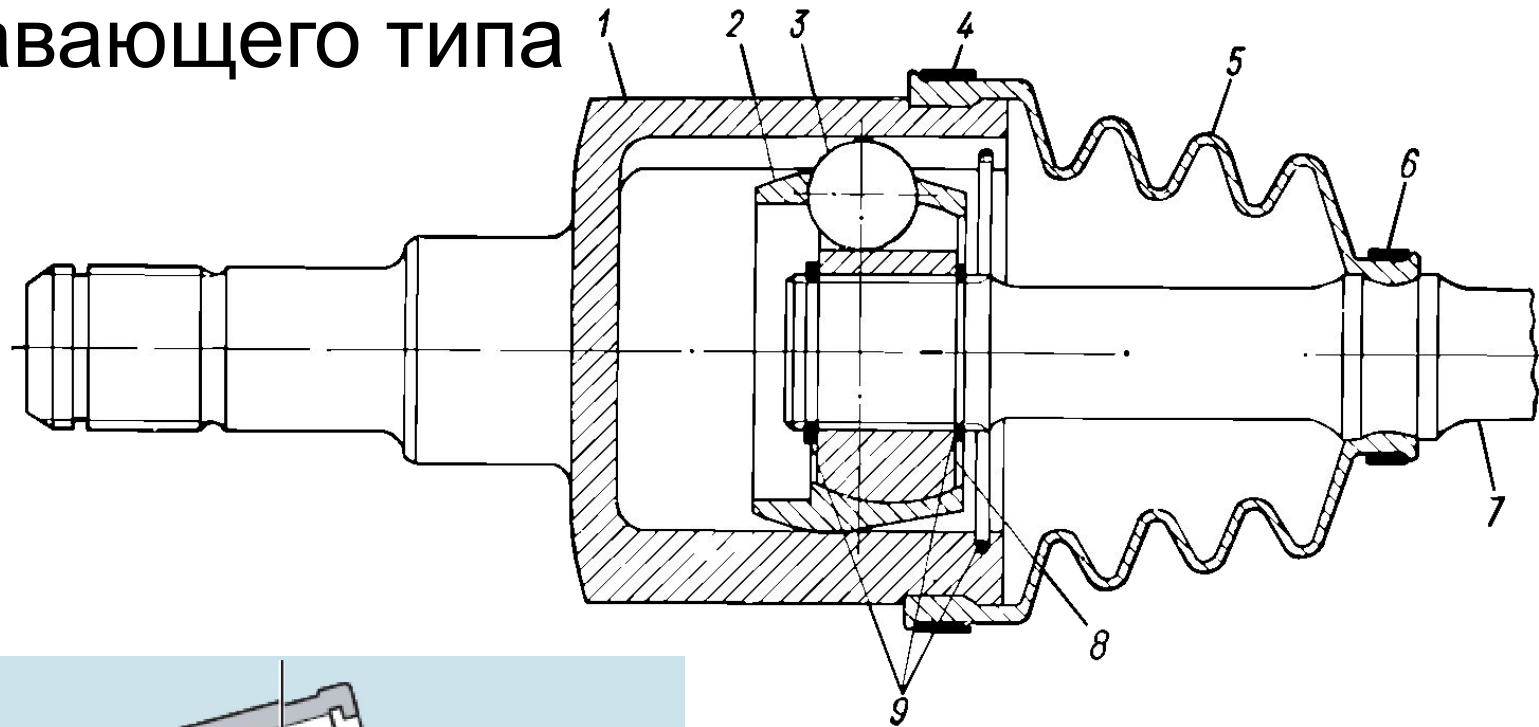

# Шарнир Трипод

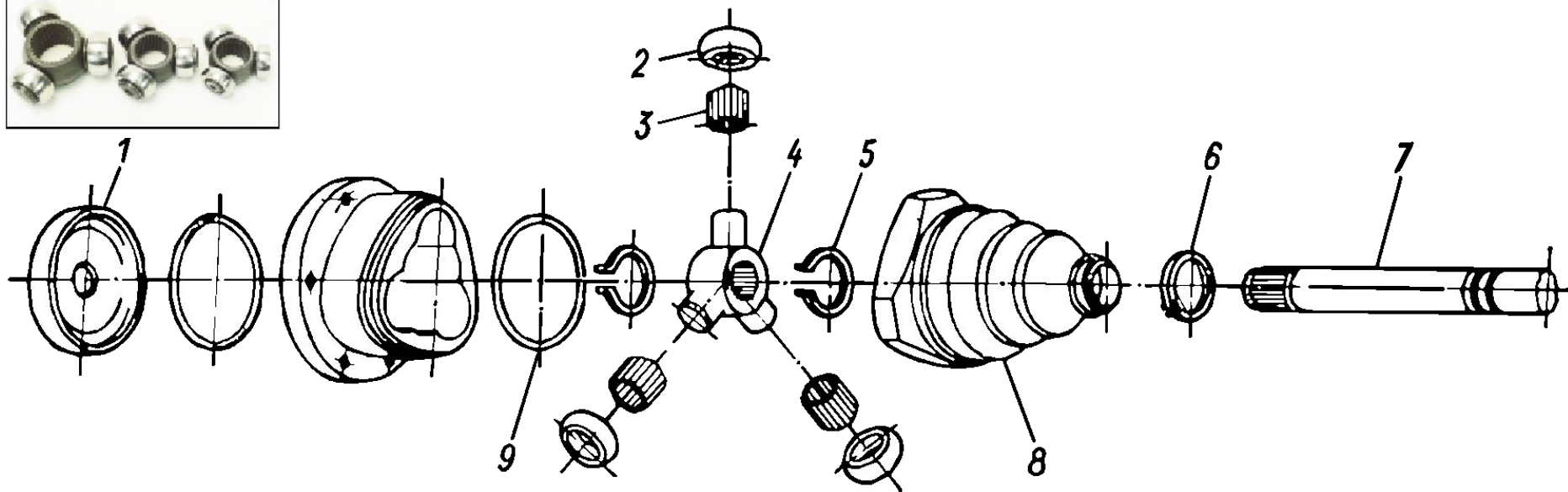
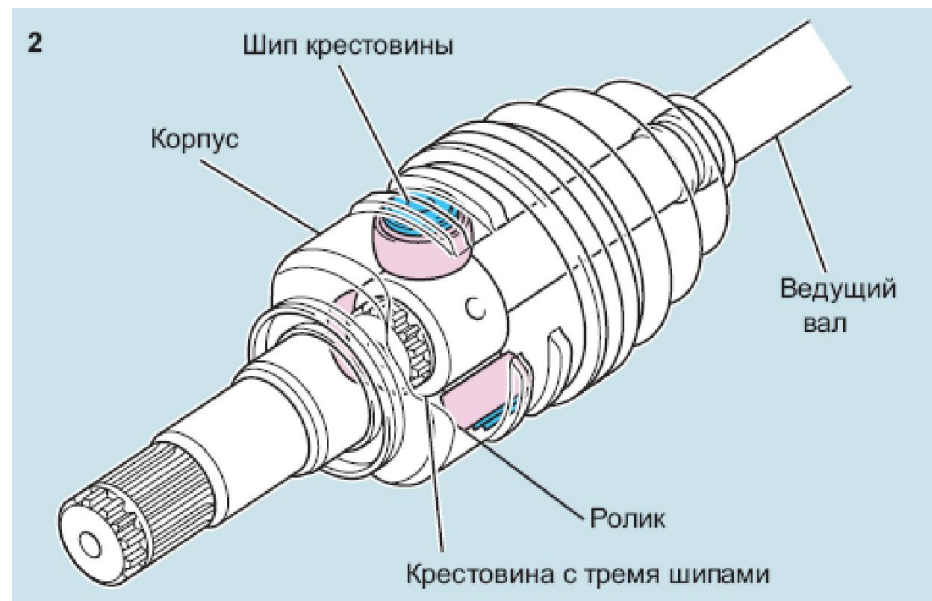



# Шарнир GKN плавающего типа



Optimized light weight easy motion high strength race version



OE specification



OE specification

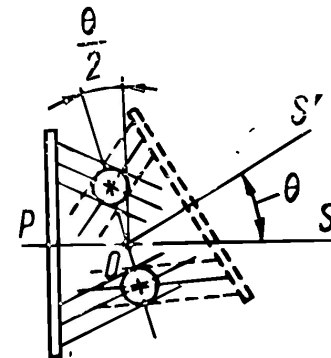
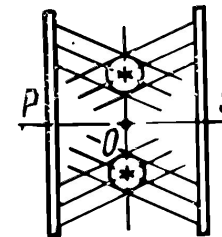
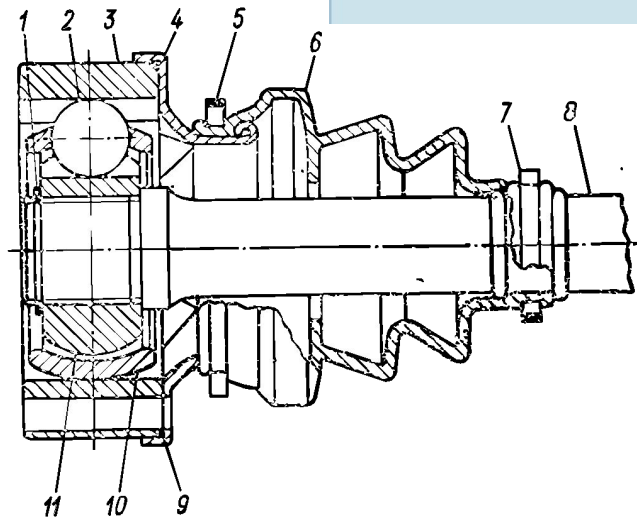
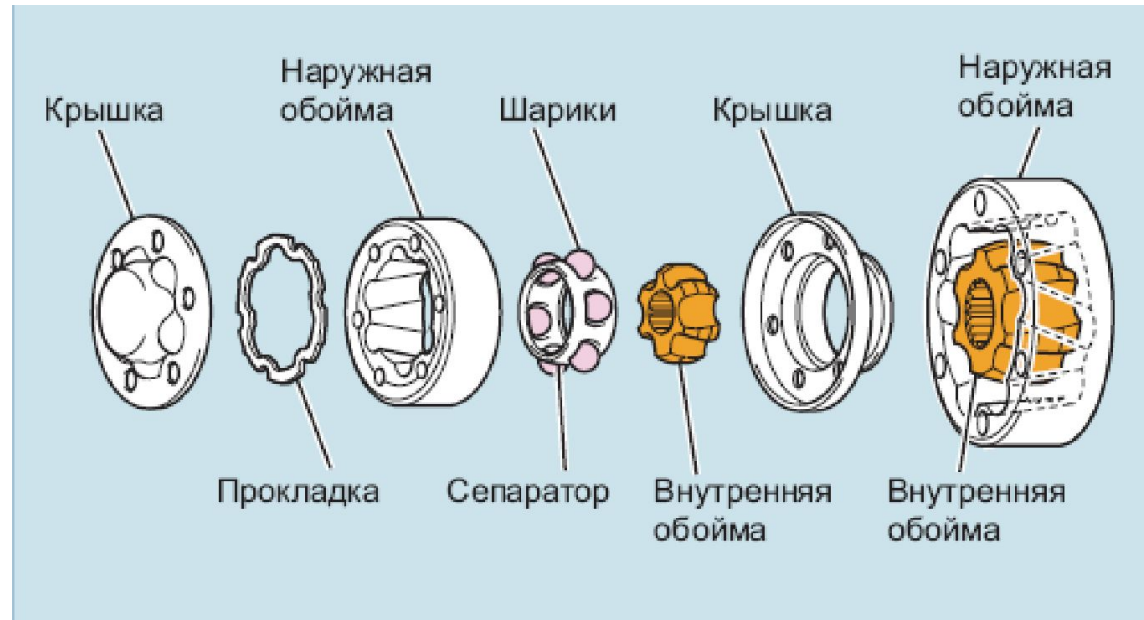

# Компенсация увода автомобиля при резком разгоне

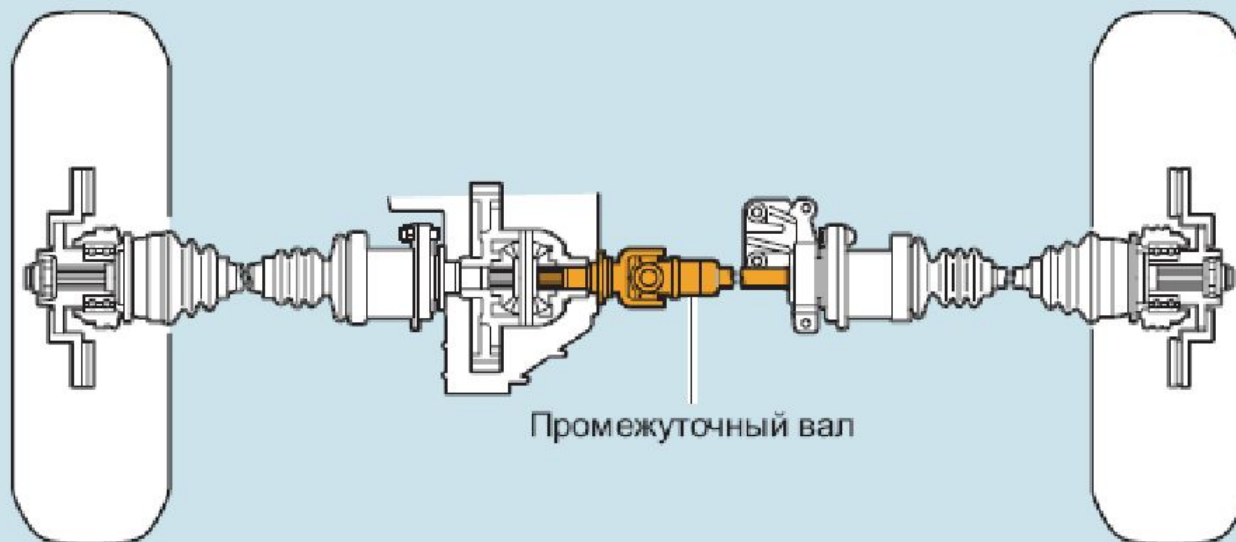
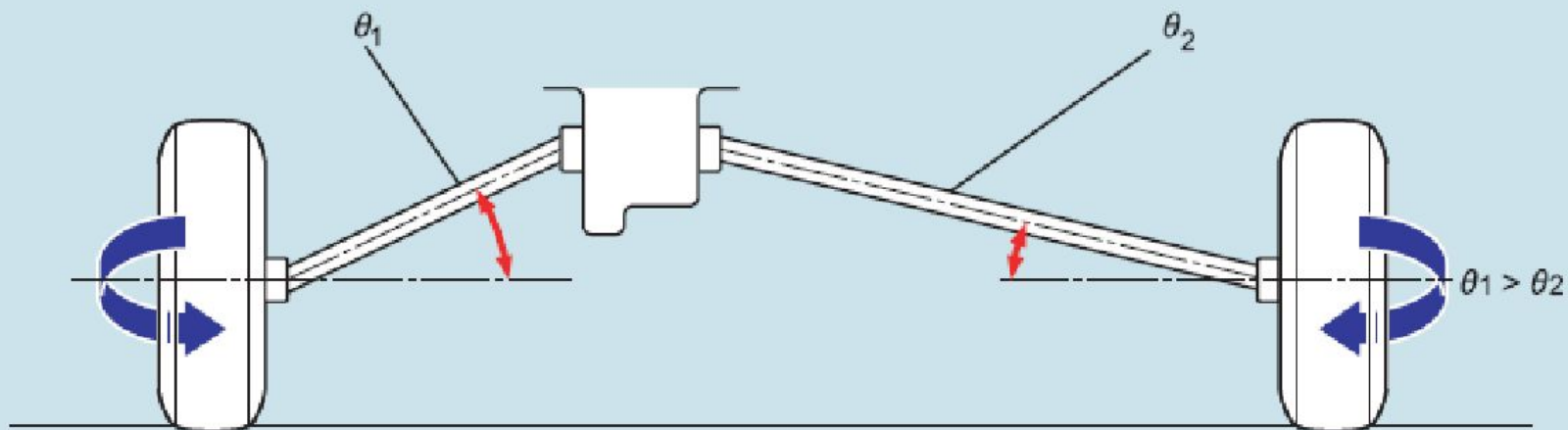

# Шарнир Вейса (Vendix)

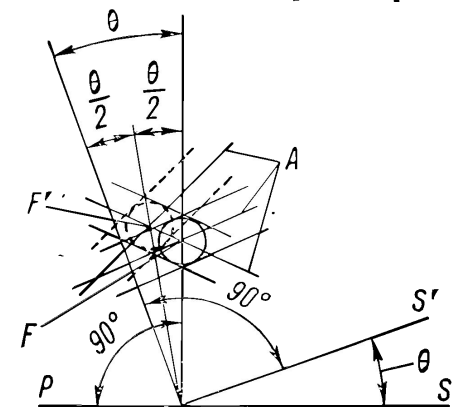
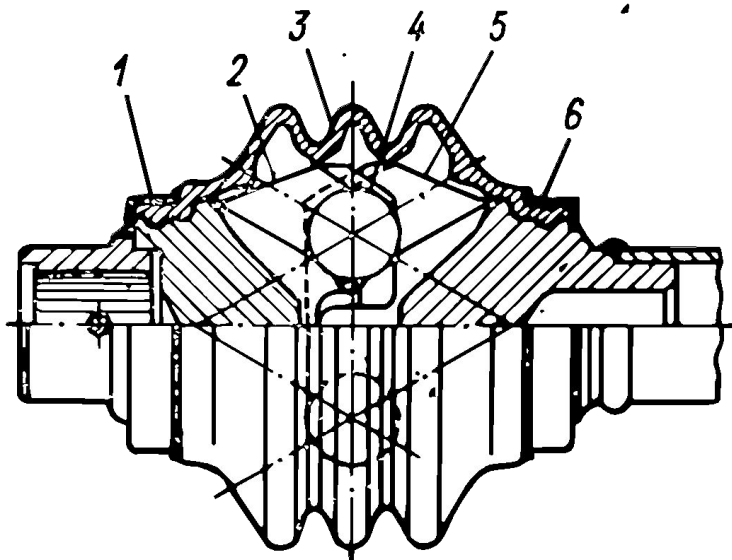
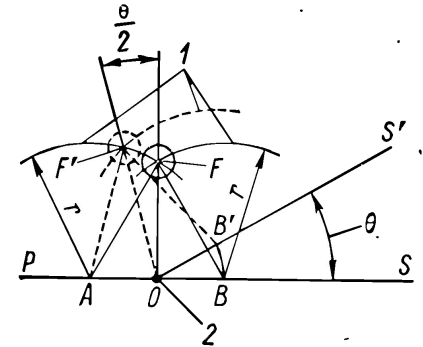
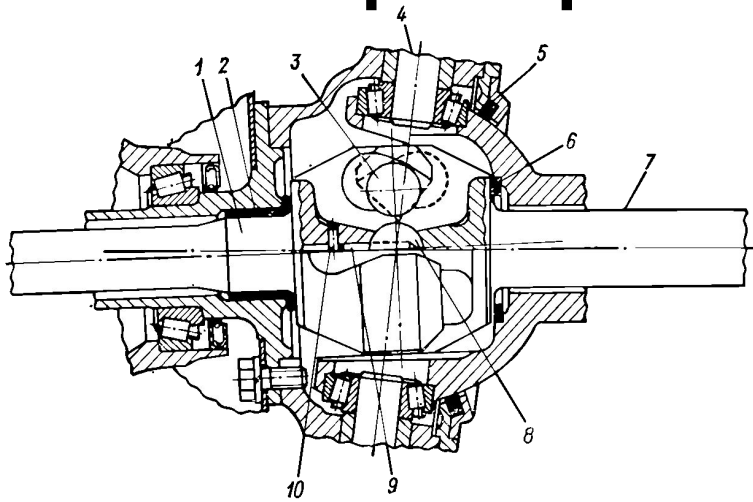

# Вибрации каплящих паралла

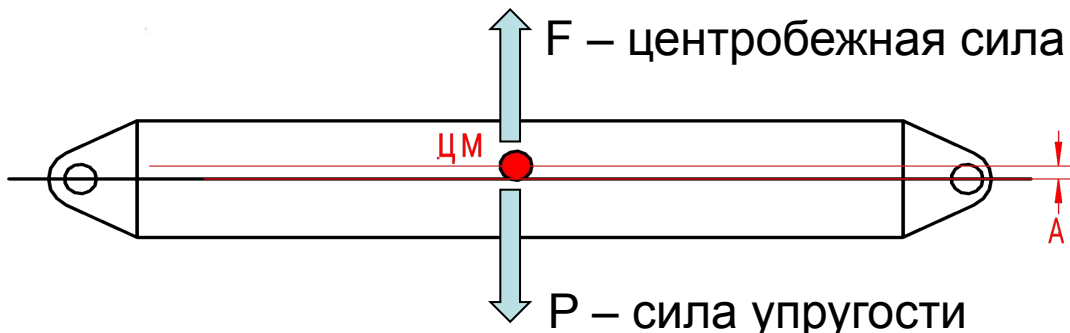
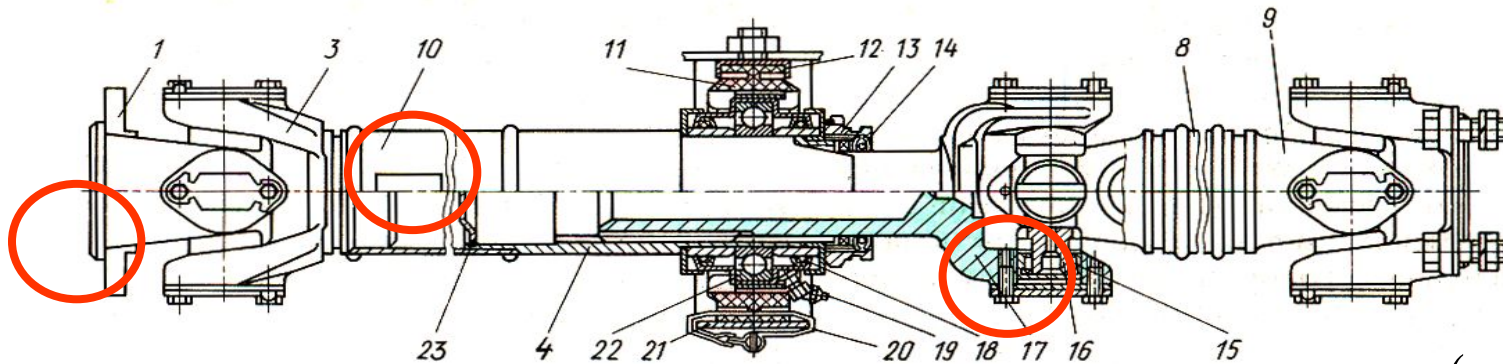

$$F = m(y + a)\omega^2$$

$$P = cy \frac{EJ_P}{l^3}$$

$$F = P$$

$$m(y + a)\omega^2 = cy \frac{EJ_P}{l^3}$$

если  $\frac{ma\omega^2}{cEJ_P - m\omega^2} = m; y = \infty$

$$\frac{cEJ_P}{l^3} - \omega^2 = 0$$

$$\omega_{KP} = \sqrt{cEJ_P / (ml^3)} \quad n_{KP} = 12 \cdot 10^4 \frac{\sqrt{D^2 + d^2}}{l^2}$$