

i20

Kappa (κ) Engine

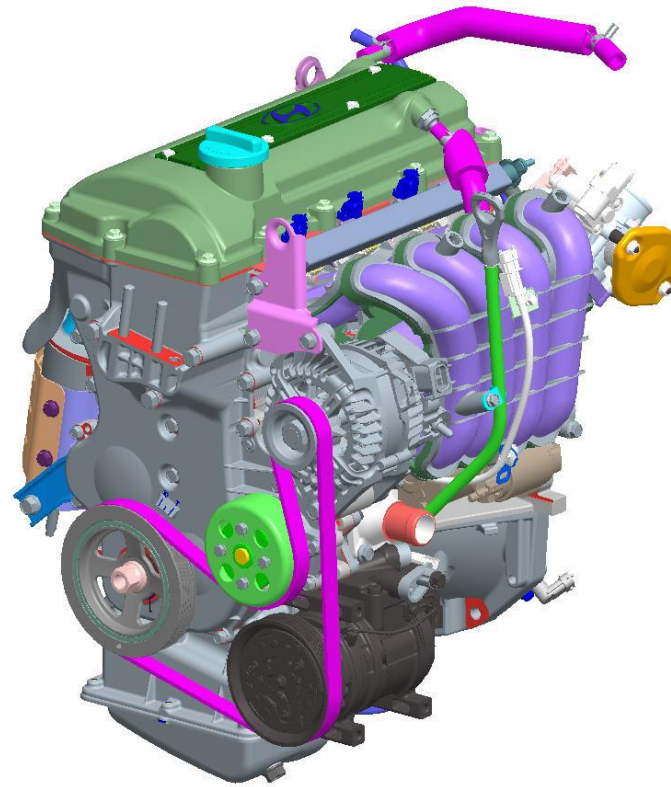

Copyright by Hyundai Motor Company. All rights reserved.

Application

Engine		Transmission		Area		
		M/T	A/T	Europe	General	India
Gasoline	Kappa 1.2L (1,197cc)	M5EF2	-	-	-	○
	Kappa 1.25L (1,248cc)			○	○	-
	Gamma 1.4	M5CF1-1	A4CF1	●	●	-
	Gamma 1.6			●	●	-
Diesel	U 1.4	M5CF2-1	-	○	○	-
	U-II 1.6	M6CF3-1	-	○	-	-

● : A/T, M/T ○ : M/T ONLY

Specification

Items	Kappa (PA)		Epsilon (TB)
	I4 1.2L	I4 1.25L	I4 1.1L
Displacement (cc)	1,197	1,248	1,086
Bore × Stroke (mm)	71×75.6	71×78.8	67×77
Bore pitch (mm)	78.5	←	72.5
Compression Ratio	10.5	←	10.1
Max. Torque (kgf.m)	11.4 / 4,000rpm	11.9 / 4,000rpm	10.1
Torque (kgf.m) @ 2000rpm	10.2	10.25	8.7
Max. Power (PS)	79 / 5,200 rpm	77 / 6,000rpm	69
Max. Speed (kph)	167	170	154

Engine Overview

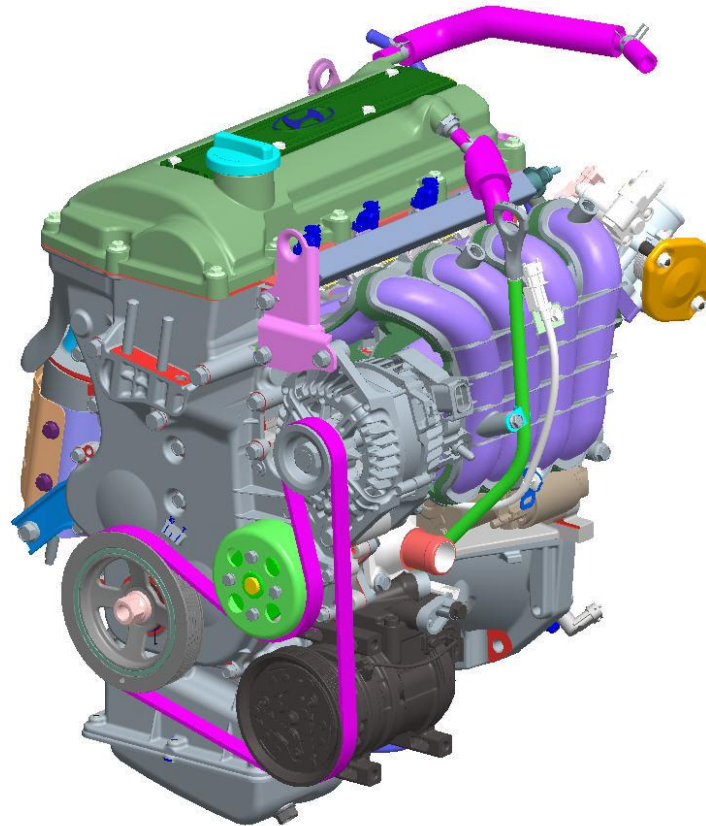
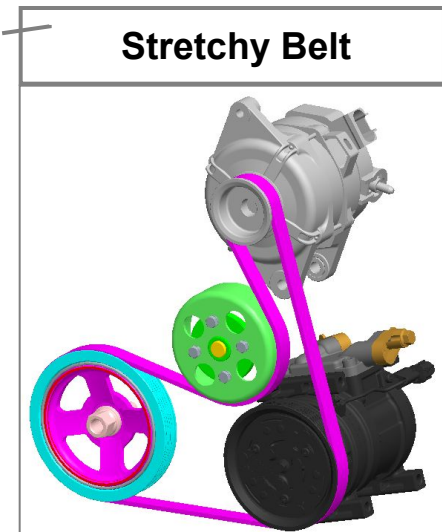
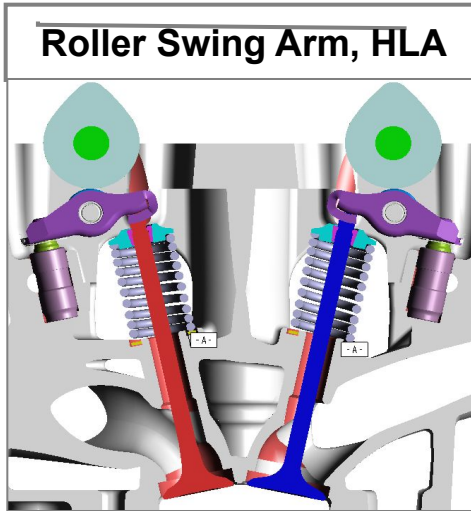

- Aluminum block
- Reversed intake and exhaust
- Timing chain

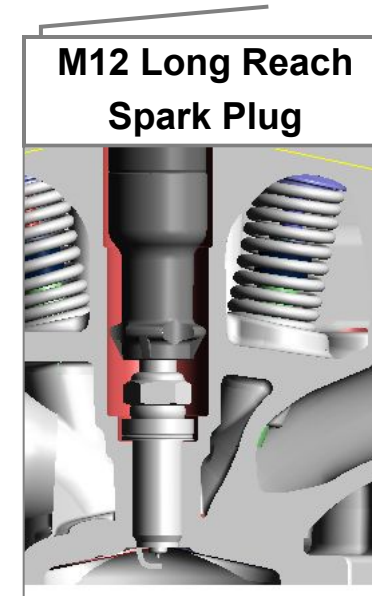

Timing Cover is combined with support bracket

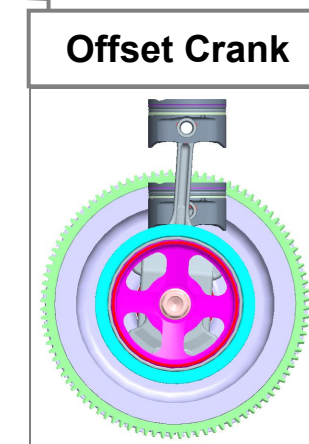

Cylinder Block / Driving Belt

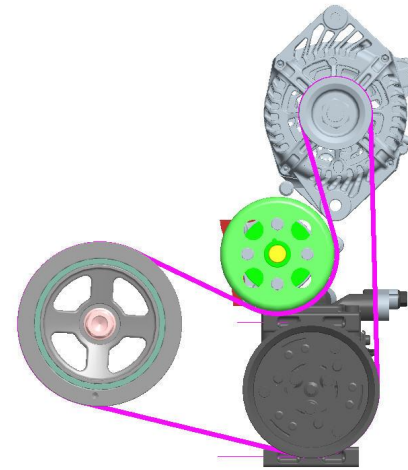
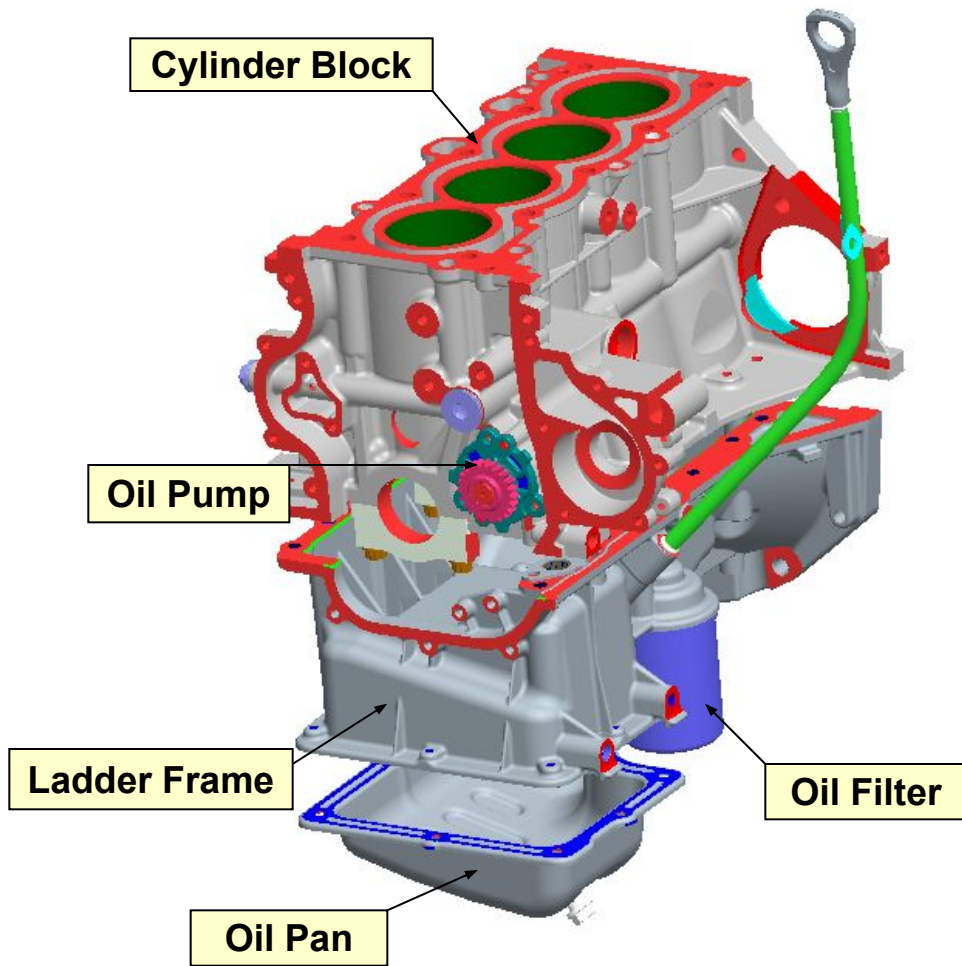

Driving Belt



SST

※ Parts No. : 09252-03100

- ▶ HPDC Aluminum Block
- ▶ Ladder frame is applied
- ▶ Stretch serpentine driving belt is used.
- ▶ Oil pump is installed in block
- ▶ Open deck

Moving Parts

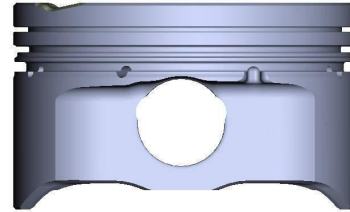
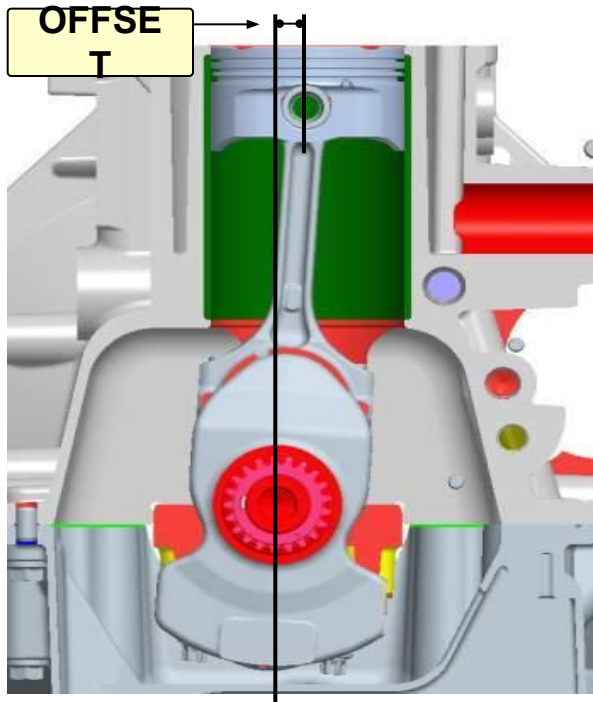

Oil Drain Hole

- ▶ Reduced side force of piston
 - Reduced fuel consumption and NVH
 - ※ Offset : Bore center and Crank bore center
- ▶ Reduced weight – 4 balance weight
- ▶ Applied oil drain hole between oil ring groove and pin hole.
 - Reduced oil consumption.
- ▶ Graphite coating (reduced friction)

1.20L

4-B/W

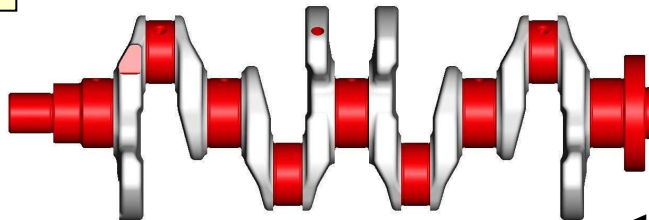

1.25L

8-B/W

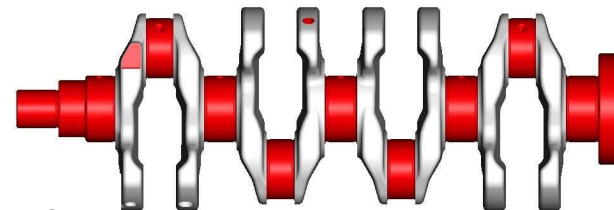

< Crankshaft

>

Cylinder Head / Cooling circuit

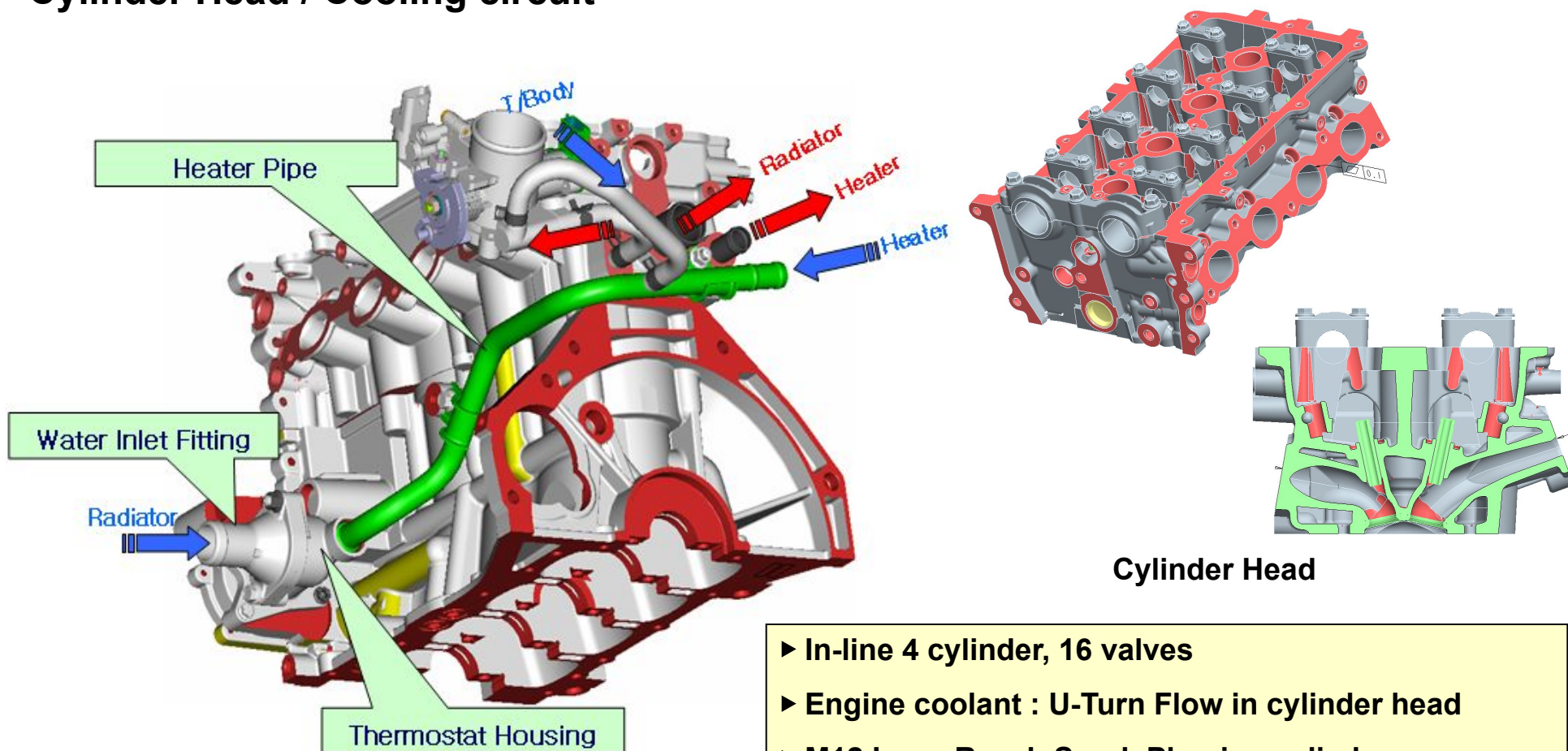

Cylinder Head

- ▶ In-line 4 cylinder, 16 valves
- ▶ Engine coolant : U-Turn Flow in cylinder head
- ▶ M12 Long Reach Spark Plug is applied
- ▶ Head bolt tightening torque : 1.5kgf.m + 90° + 120°
- ▶ Wax type thermo-state : inlet control
- ▶ ECT sensor is installed on cylinder head

Timing Chain / Valve Train

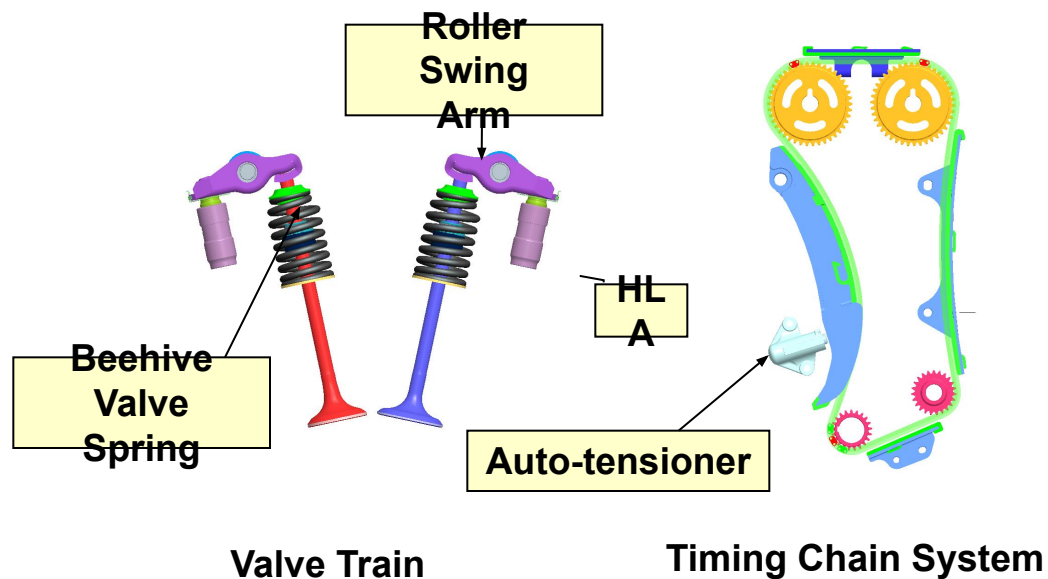
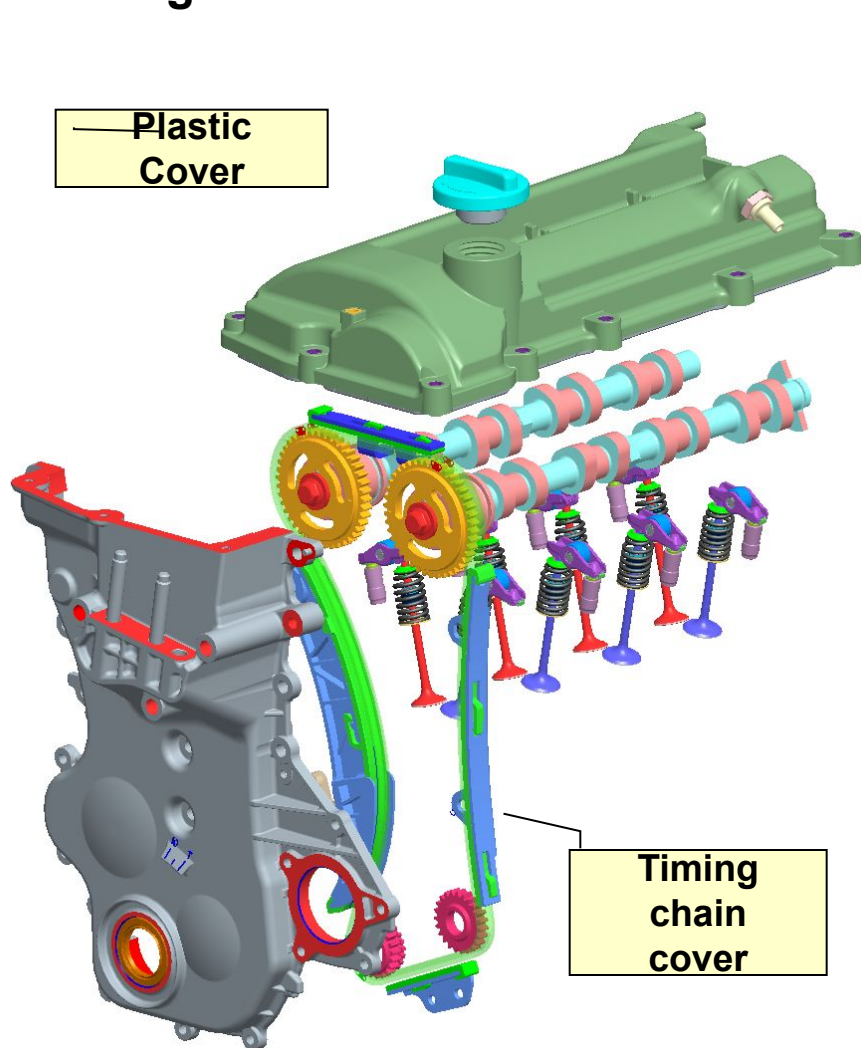

- ▶ Support bracket is combined with timing chain cover
- ▶ Roller swing arm & HLA (Improved fuel consumption)
- ▶ Beehive Valve spring (Improved fuel consumption)
- ▶ Plastic P.C.V.-Valve (Reduced weight)
- ▶ Silent timing chain (Improved NVH)
- ▶ Oil pump is operated by timing chain (1 timing chain)

Timing Chain Marks

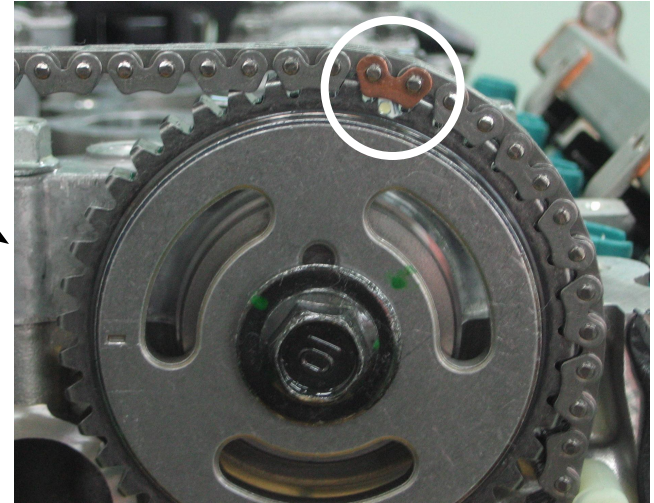
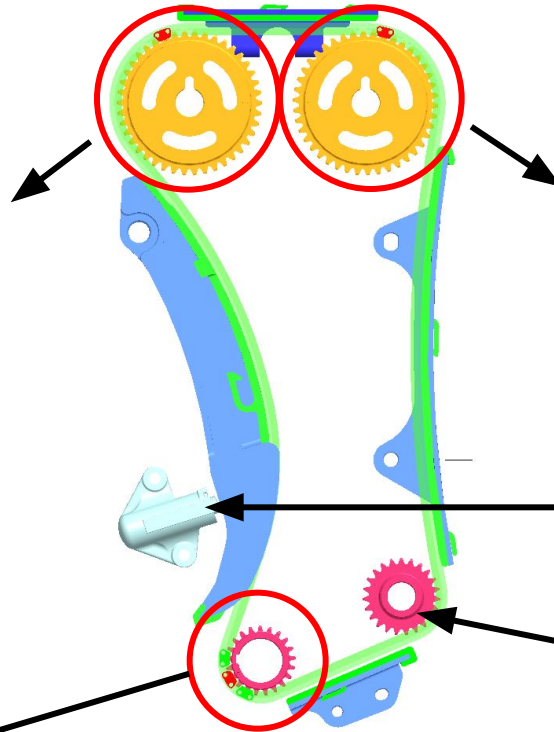
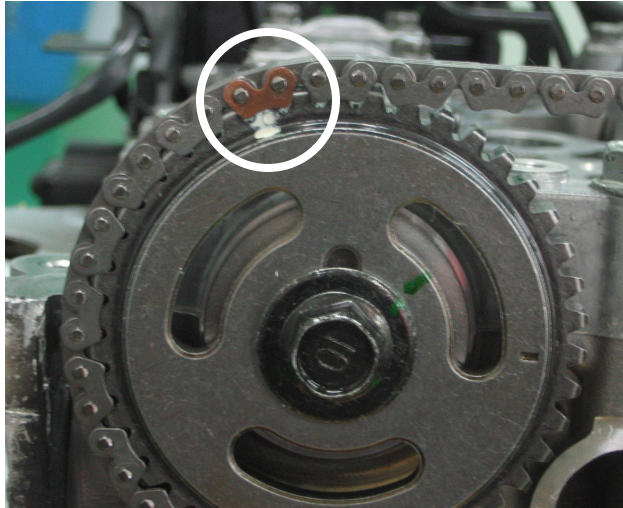

Auto-tensioner

Oil Pump Sprocket



Timing Chain System

Intake / Exhaust Manifold

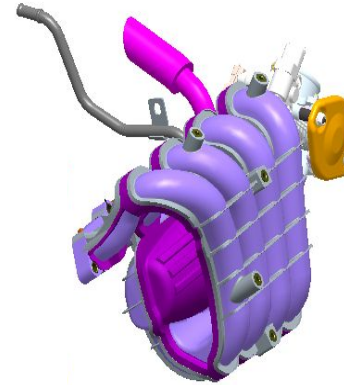
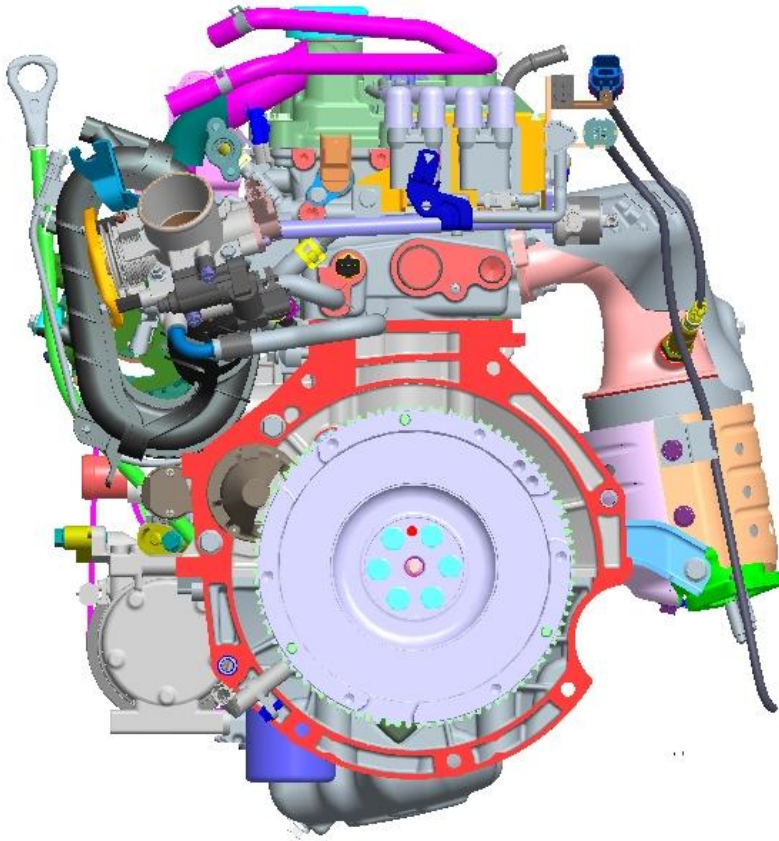

**Intake
Manifold**

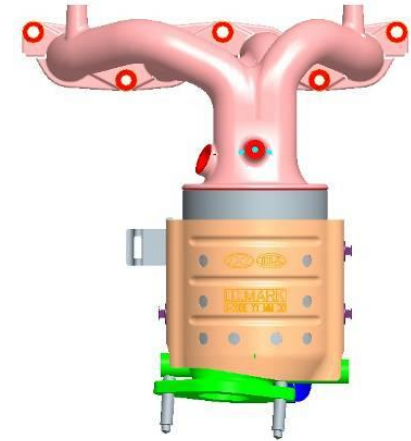

**Exhaust
Manifold**

- ▶ Plastic intake manifold : Reduced weight
- ▶ Cast iron exhaust manifold
- ▶ Intake and exhaust manifold is reversed
- ▶ Rosa type ISA is applied
- ▶ WCC is used

Location of EMS Components

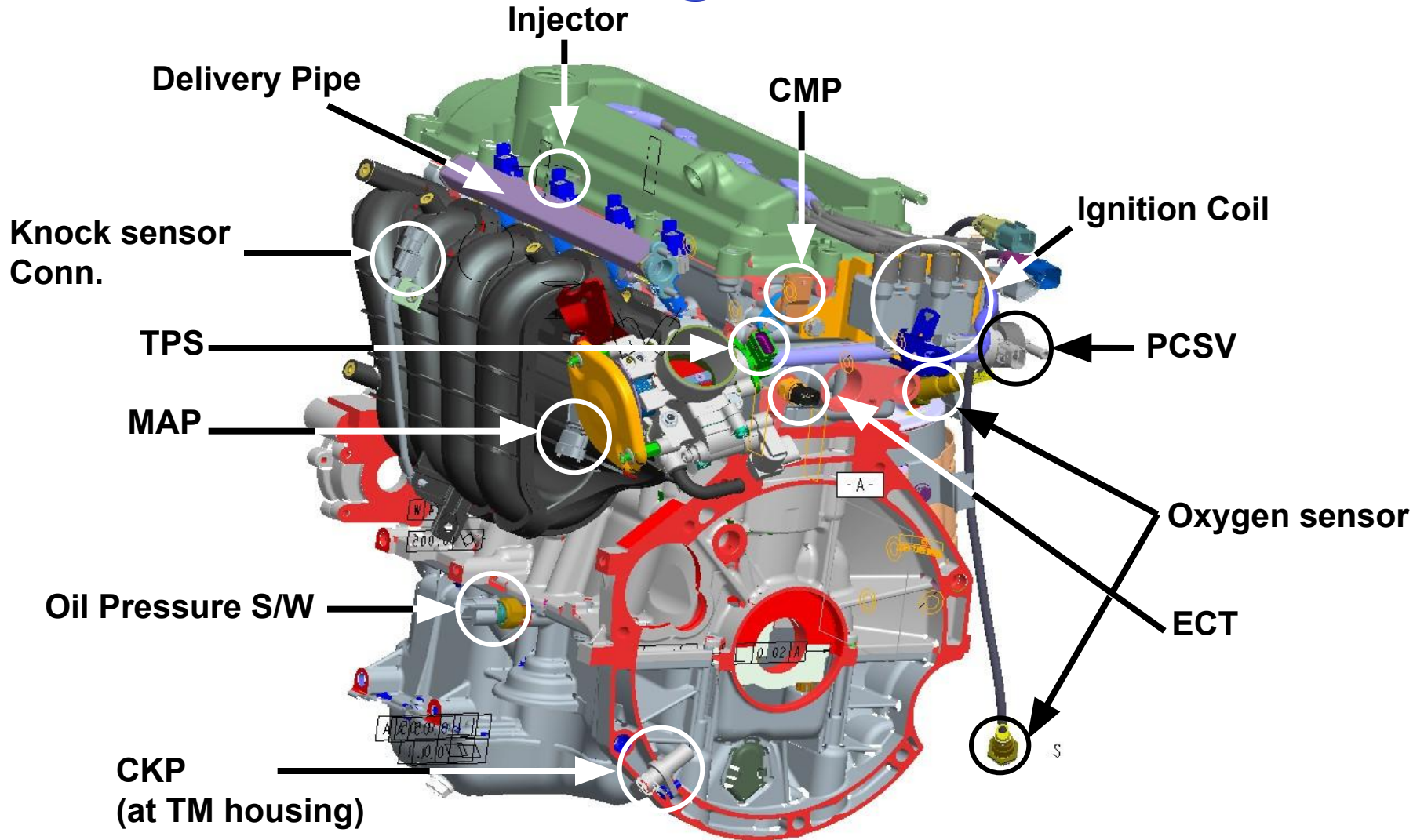

EMS Components

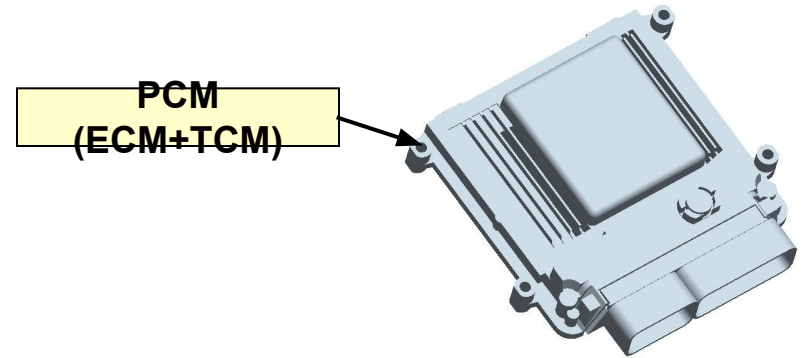
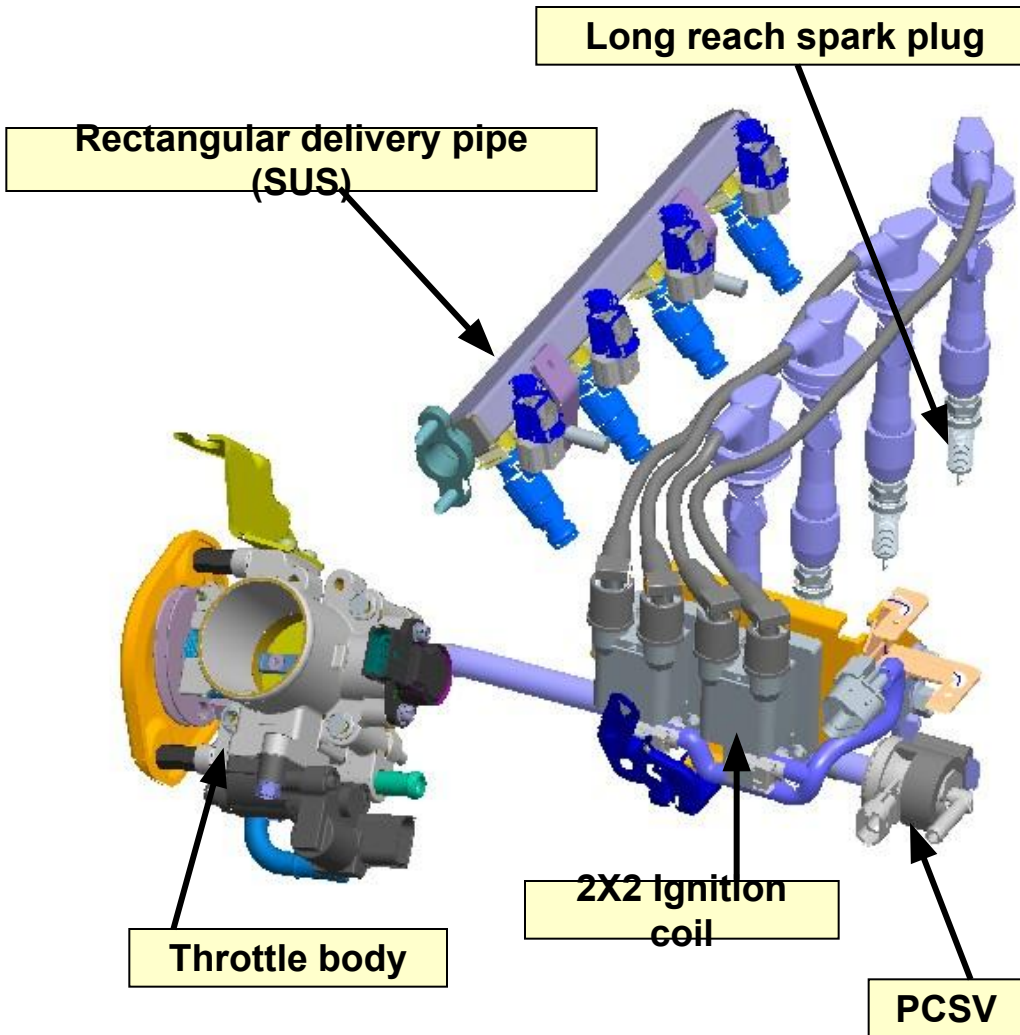

154pin

- ▶ PCM (Powertrain Control Module) - ECM + TCM
- ▶ M12 Long Reach Spark Plug
- ▶ Mechanical type throttle valve
- ▶ 2X2 Ignition Coil
- ▶ Rectangular delivery pipe (SUS)
- No needed damper

GDS – Current Data at Idle

Current Data						
<input type="checkbox"/> Selective Display <input type="checkbox"/> Full List <input type="checkbox"/> Graph						
Sensor Name	IG ON	Idle	1500rpm	3000rpm	Red zone	Unit
	Value	Value	Value	Value	Value	
<input type="checkbox"/> Transaxle Range Switch	P,N,R	P,N,R	P,N,R	P,N,R	P,N,R	-
<input type="checkbox"/> A/C On Condition	OFF	OFF	OFF	OFF	OFF	-
<input type="checkbox"/> A/C Switch	OFF	OFF	OFF	OFF	OFF	-
<input type="checkbox"/> Malfunction Indicator Lamp(MIL)	ON	OFF	OFF	OFF	OFF	-
<input type="checkbox"/> A/C Compressor	OFF	OFF	OFF	OFF	OFF	-
<input type="checkbox"/> Fan-Low Speed	OFF	OFF	OFF	OFF	OFF	-
<input type="checkbox"/> Fan-High Speed	OFF	OFF	OFF	OFF	OFF	-
<input type="checkbox"/> Ignition Voltage	ON	ON	ON	ON	ON	-
<input type="checkbox"/> Closed Throttle Position	ON	ON	OFF	OFF	OFF	-
<input type="checkbox"/> Wide Open Throttle(WOT)	OFF	OFF	OFF	OFF	ON	-
<input type="checkbox"/> Fuel Cut Status	OFF	OFF	OFF	OFF	OFF	-
<input type="checkbox"/> Cranking Signal	OFF	OFF	OFF	OFF	OFF	-
<input type="checkbox"/> Fuel Pump	OFF	ON	ON	ON	ON	-
<input type="checkbox"/> MFI Control Relay	ON	ON	ON	ON	ON	-
<input type="checkbox"/> Synchronizing Status-CKP/CMP	ON	ON	ON	ON	ON	-
<input type="checkbox"/> A/F Closed Loop Control Active(Bank 1/Sensor 1)	OFF	ON	ON	ON	OFF	-
<input type="checkbox"/> Knocking Detection	OFF	OFF	OFF	OFF	OFF	-
<input type="checkbox"/> Engine Running Status	OFF	ON	ON	ON	ON	-
<input type="checkbox"/> CVVT Actuation Status	OFF	OFF	OFF	OFF	OFF	-
<input type="checkbox"/> Oxygen Sensor Operation-Bank1/Sensor1	OFF	ON	ON	ON	ON	-
<input type="checkbox"/> Canister Purge State	OFF	OFF	ON	ON	OFF	-

GDS – Current Data at Idle

Current Data						
Sensor Name	IG ON	Idle	1500rpm	3000rpm	Red zone	Unit
<input type="checkbox"/> Canister Phase On	OFF	OFF	ON	ON	ON	-
<input type="checkbox"/> Idle Control State	ON	ON	OFF	OFF	OFF	-
<input type="checkbox"/> Manifold Absolute Pressure Sensor	4.0	1.5	1.1	0.9	3.7	V
<input type="checkbox"/> Manifold Absolute Pressure Sensor	1003	369	275	232	949	hPa
<input type="checkbox"/> Engine Load	100.0	22.3	15.7	14.5	67.9	%
<input type="checkbox"/> Throttle Position	0.5	0.4	0.5	0.5	2.5	V
<input type="checkbox"/> Throttle Position	0.0	0.0	1.2	2.4	42.7	%
<input type="checkbox"/> Adapted Throttle Position	9.3	8.5	8.5	8.5	8.6	%
<input type="checkbox"/> Battery Positive Voltage	12.6	14.0	14.2	14.2	14.2	V
<input type="checkbox"/> Battery Charging	9.4	0.0	0.0	0.0	0.0	%
<input type="checkbox"/> Engine Coolant Temperature Sensor	103	77	80	84	94	'C
<input type="checkbox"/> Intake Air Temperature Sensor	38	35	35	36	36	'C
<input type="checkbox"/> EVAP Purge Valve	0.0	0.0	5.1	11.0	0.0	%
<input type="checkbox"/> Cylinder 1 Injection Time	0.0	3.1	2.1	1.9	11.1	mS
<input type="checkbox"/> Cylinder 2 Injection Time	0.0	3.1	2.1	1.9	11.1	mS
<input type="checkbox"/> Cylinder 3 Injection Time	0.0	3.2	2.1	1.9	11.0	mS
<input type="checkbox"/> Cylinder 4 Injection Time	0.0	3.2	2.1	1.9	9.9	mS
<input type="checkbox"/> Actual Torque	0.0	11.5	11.8	11.9	0.0	%
<input type="checkbox"/> Torque Request From TCU	100.0	100.0	100.0	100.0	100.0	%
<input type="checkbox"/> Oxygen Sensor-Bank1/Sensor1	0.17	0.52	0.47	0.74	0.13	V
<input type="checkbox"/> Target Idle Speed	680	710	1410	1480	1480	RPM

GDS – Current Data at Idle

Current Data						
<input type="checkbox"/> Selective Display <input type="checkbox"/> Full List <input type="checkbox"/> Graph <input type="checkbox"/> Record						
Sensor Name	IG ON	Idle	1500rpm	3000rpm	Red zone	Unit
<input type="checkbox"/> Idle Speed Control Actuator	46.5	17.6	17.6	40.5	94.5	%
<input type="checkbox"/> Engine Speed-Fine	0	726	1403	3143	6546	RPM
<input type="checkbox"/> Engine Oil Temperature	94	65	72	76	80	'C
<input type="checkbox"/> Calculated Oil Temperature	94	65	72	76	80	'C
<input type="checkbox"/> Ignition Timing Advance for 1 Cylinder	TDC 0	BTDC 3	BTDC 24	BTDC 34	BTDC 29	'
<input type="checkbox"/> Ignition Timing Advance for 2 Cylinder	TDC 0	BTDC 3	BTDC 24	BTDC 34	BTDC 29	'
<input type="checkbox"/> Ignition Timing Advance for 3 Cylinder	TDC 0	BTDC 3	BTDC 24	BTDC 34	BTDC 29	'
<input type="checkbox"/> Ignition Timing Advance for 4 Cylinder	TDC 0	BTDC 3	BTDC 24	BTDC 34	BTDC 29	'
<input type="checkbox"/> Vehicle Speed	0	0	0	0	0	km/h
<input type="checkbox"/> Short Term Fuel Trim	-1.7	22.9	-8.5	-0.2	-1.7	%
<input type="checkbox"/> Long Term Fuel Trim-Idle Load	-7.6	-5.2	-2.6	-1.2	-0.6	%
<input type="checkbox"/> Long Term Fuel Trim-Part Load	-1.7	-1.7	-1.7	-1.7	-1.7	%
<input type="checkbox"/> Knock Adaption-Cylinder 1	0.0	0.0	0.0	0.0	0.0	'
<input type="checkbox"/> Knock Adaption-Cylinder 2	0.0	0.0	0.0	0.0	0.0	'
<input type="checkbox"/> Knock Adaption-Cylinder 3	0.0	0.0	0.0	0.0	0.0	'
<input type="checkbox"/> Knock Adaption-Cylinder 4	0.0	0.0	0.0	0.0	0.0	'
<input type="checkbox"/> Camshaft Adaption-#1	158.9	158.6	158.6	159.0	158.9	'
<input type="checkbox"/> Camshaft Adaption-#2	524.0	524.3	524.3	524.2	524.0	'
<input type="checkbox"/> Angle Between CKP & CMP #1	0.0	523.8	524.0	158.4	159.6	'
<input type="checkbox"/> Camshaft Actual Position	11.8	11.3	11.5	11.2	12.5	'
<input type="checkbox"/> Camshaft Position-Target	11.8	11.8	11.8	11.8	11.8	'