



**UNIMECH INDUSTRIES (P) LTD.**

*“Delivering Trust and  
Quality”*

## DWG Ref: 1316.350.080.00.200 CB (802 Kg Casting)

- Notes to be translated in English if possible
- Part Drg. Required for Det. No. 2,3 & 4 . – Part No. 4 not identified the location in the print. View M detail required
- Special Boring Bar – 3 Nos. to be made.
- ( $\varnothing 308 \times 600\text{mm L}$  ,  $\varnothing 90.0 \times 350 \text{ L}$  &  $\varnothing 125.0 \times 680 \text{ L}$  or  $\varnothing 70 \times 450 \text{ L}$  Back Boring Bar) – Enquiry sent to manufacturer.  
Bore Grooving tool with corner radius R3 – to be made. - Enquiry sent to manufacturer. Waiting for quote.
- $\varnothing 332.0$  bore depth required
- M120 x 4 - 7H Inner Thread Length required
- M120 thread relief details required.
- M360 x 6 - 7H Thread Length or Thread relief distance required.
- Surface Finish Ra 2.5 achievable on critical bores instead of Ra1.25.
- Details required for the 4 Holes / Grooves in View b.

# DWG Ref: 1316.350.080.00.200 CB (802 Kg Casting)

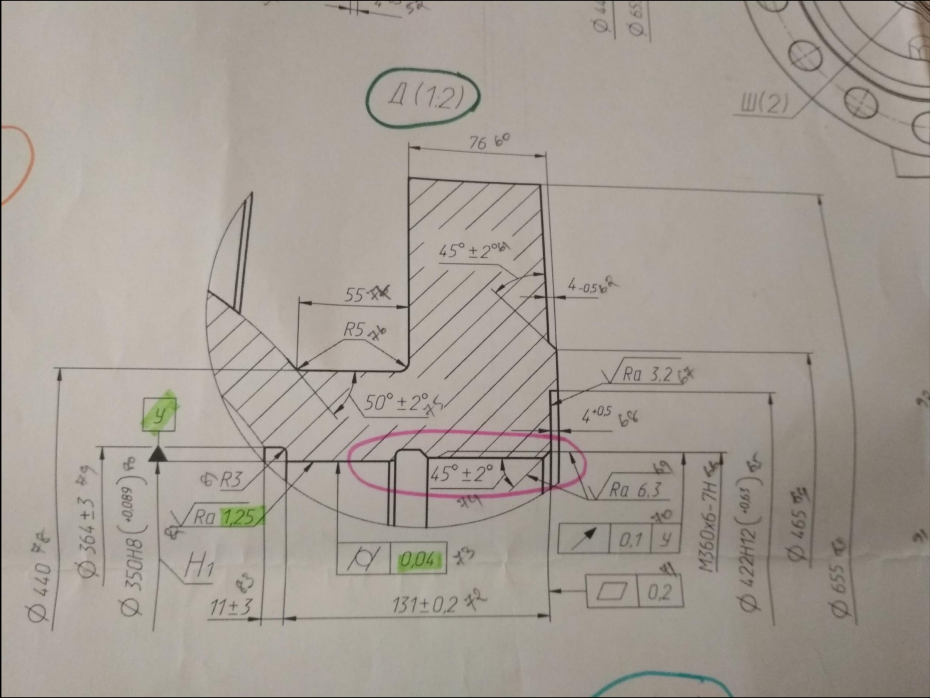

Ref Image 1

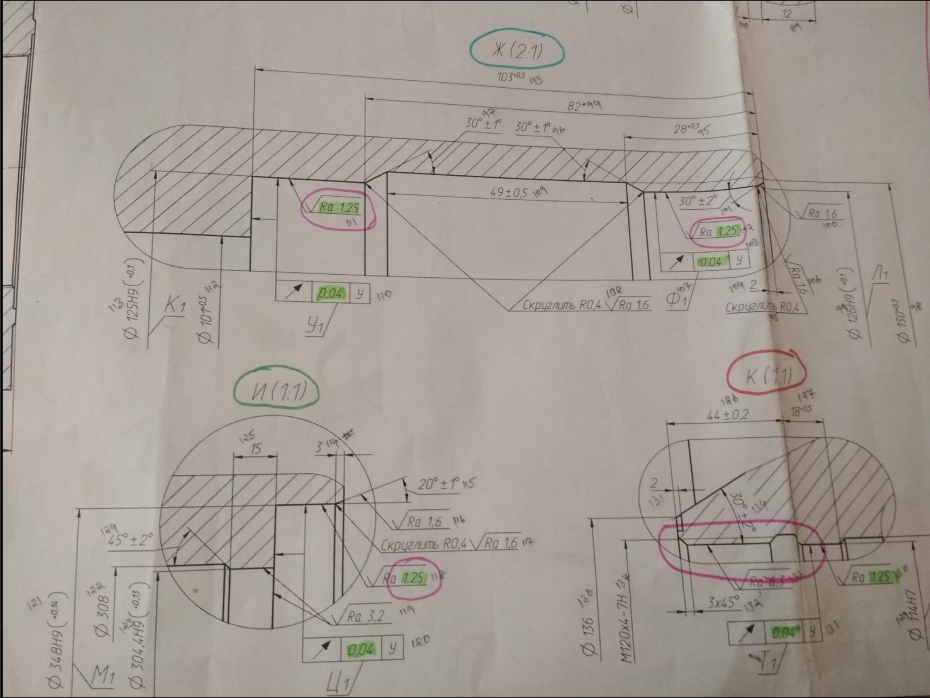

Ref Image 2

DWG Ref: 1316.350.080.00.200 CB (802 Kg Casting)

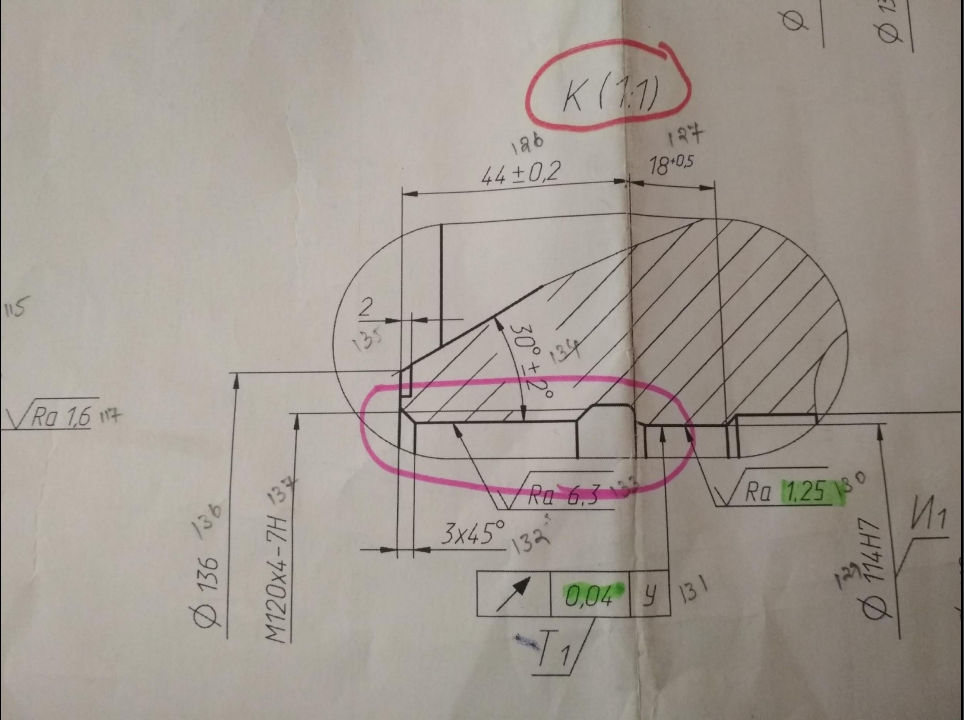

Ref Image 3

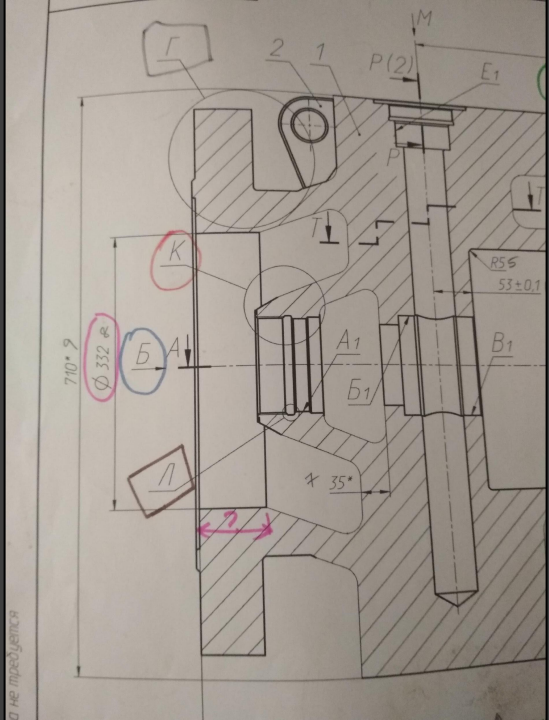

Ref Image 4

# DWG Ref: 1316.350.080.00.200 CB (802 Kg Casting)

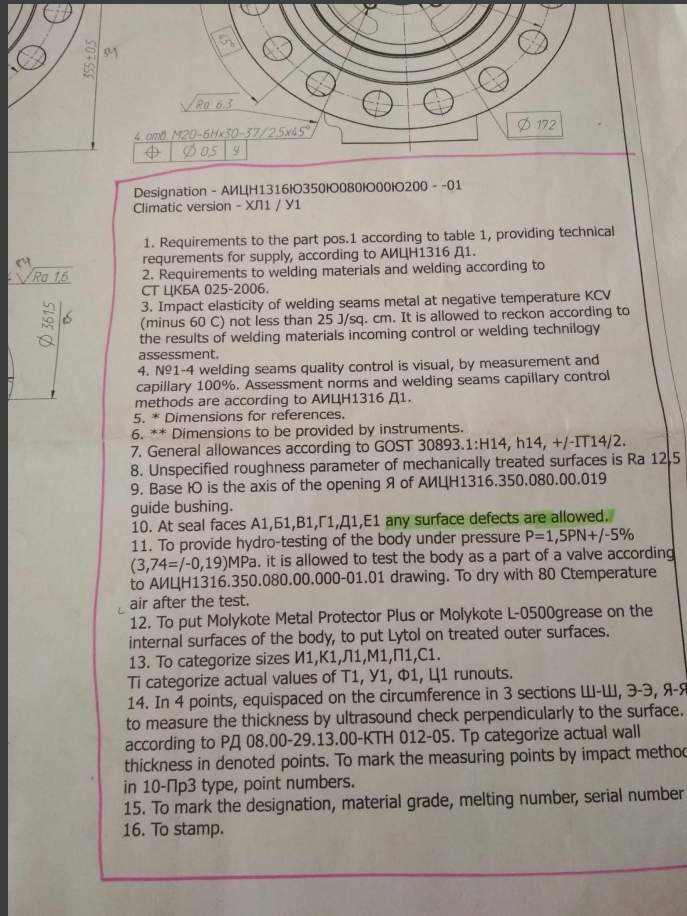

Point 10: No surface defects are allowed?

Ref Image 5

## DWG Ref: АИЦН1244.0700.160.00.001 (4833 Kg Casting)

- Details Required for the bores K(2) , ^ (3) & M (3)
- View A ( 2 ) Detail required.
- View X detail not possible to under stand.
- Face Groove B, detail given in the drg. Not marked as B. To be confirmed



DWG Ref: АИЦН1244.0700.160.00.001 (4833 Kg Casting)

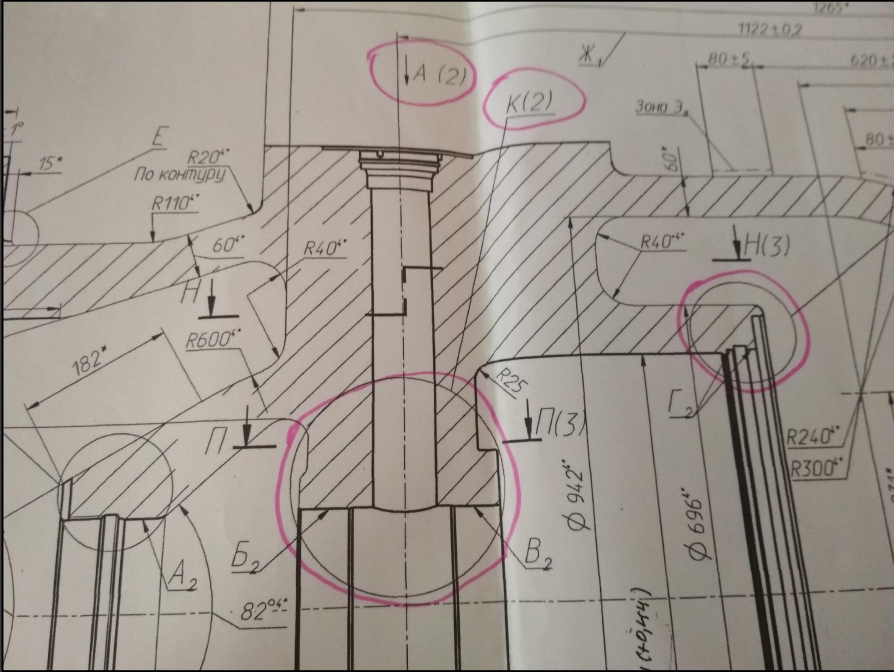
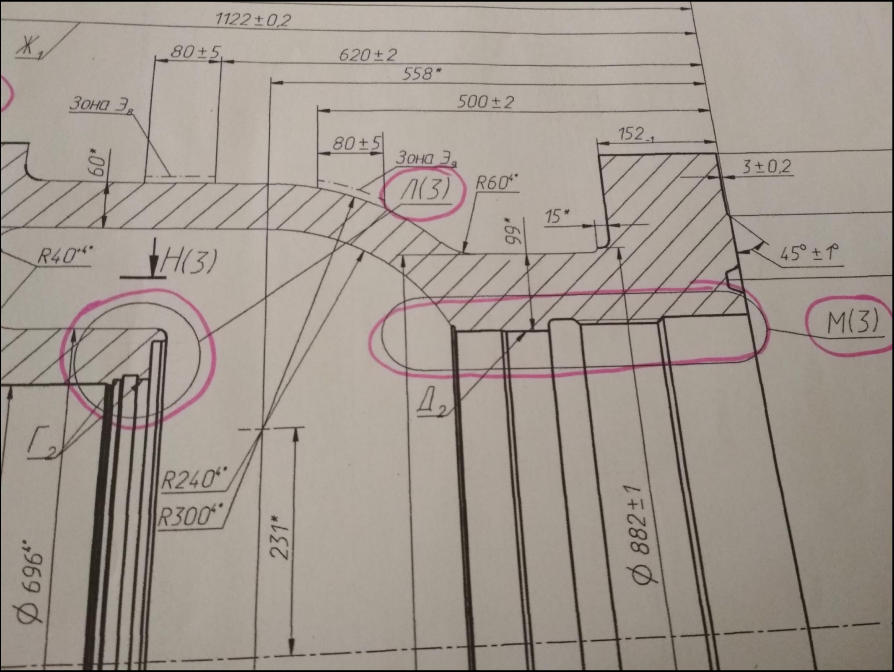

# DWG Ref: АИЦН1244.0700.160.00.001 (4833 Kg Casting)

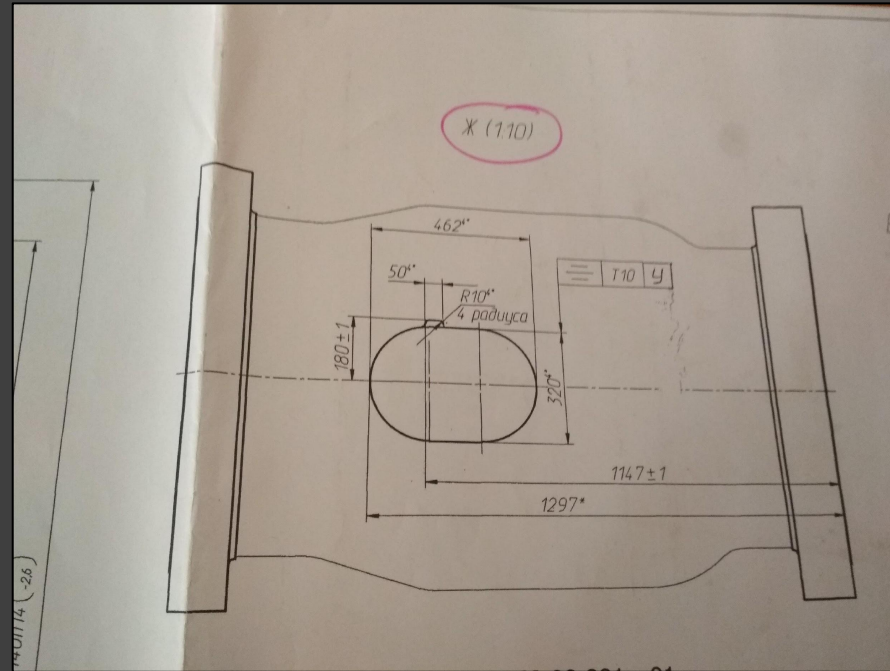
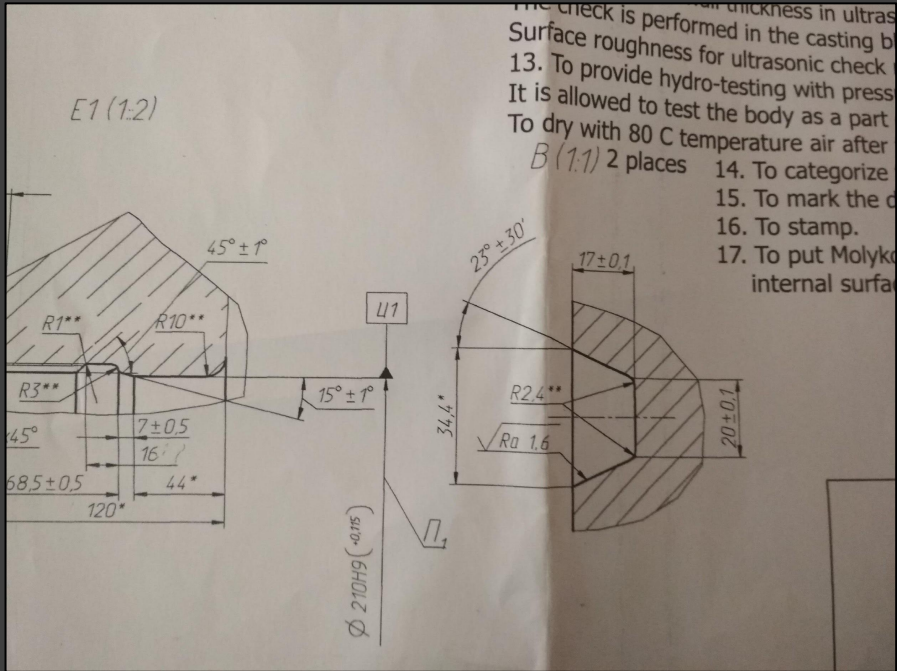



DWG Ref: АИЦН1244.0700.160.00.001 (4833 Kg Casting)

