

Aminolysis of 3,4-epoxysulfolane **1** with an excess of aqueous ammonia leads to a complex mixture of sulfolane derivatives that were isolated and identified as *trans*- and *cis*-3-hydroxy-4-aminosulfolanes **2a,b**, ether **3** and *trans*- and *cis*-3,4-dihydroxysulfonanes **5a,b**.

Since obtained experimental data do not allow us to do an unambiguous conclusion in relation to the mechanism of epoxide **1** transformation, we have performed quantum-chemical investigation of limiting stages of possible routes.

### Computation details

The geometries of structures of reactant complexes, intermediates, transition states and product were optimized using the M06-2X levels in conjunction with the 6-31++(d,p) basis set. Harmonic vibration frequencies were calculated at the same level of theory to characterize the stationary points (minima with all positive frequencies or transition state with only one imaginary frequency) and to calculate zero-point vibration energy.

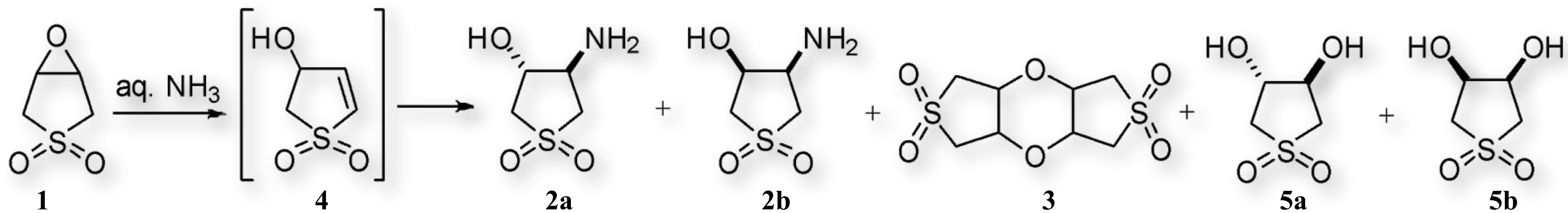

### Results

First we considered pathways of primary transformation of epoxide: back-side attack of ammonia (A1), water (A2) molecules or hydroxy anion (A3), giving *trans*-aminoalcohol **2a** or diol **5a** via SN2-like mechanism; formation of *cis*-aminoalcohol **2b** or diol **5b** by front-side attack of nucleophiles (pathways B1 - B3); and the isomerization of epoxide **1** into allylic alcohol **4** (pathway C). Next we investigated transformation of alcohol **4** which, reacting with nucleophiles, form either *trans*- **2a**, **5a** or *cis*- **2b**, **5b** products (pathways D1-D3, E1-E3). Comparison of activation barriers (fig. 1) for *trans* and *cis* opening of epoxidic ring clearly demonstrates preference of back-side attack over *cis* opening. Difference between activation barriers for *trans* and *cis* opening lies in the range 90-100 kJ/mol.

Comparison of the  $\Delta E^\ddagger$  values for routes C1 and A1-A3 let us presume that for reactions involved NH<sub>3</sub> molecule rearrangement could be considered as competing mechanisms to *trans* opening. Transition state TS<sub>C1</sub> consistent with concerted but highly asynchronous process where proton from the CH<sub>2</sub> group is transferred to the nitrogen atom while forming H-O<sub>ep</sub> bond remains within hydrogen bond length (around 2 Å).

Values of  $\Delta E^\ddagger$  for addition of nucleophiles to allylic alcohol (**2**) increase in the row OH<sup>-</sup><NH<sub>3</sub><H<sub>2</sub>O, herewith lengths of forming C<sub>1</sub>-X (X = N or O) bonds decrease in the same order. For addition of NH<sub>3</sub> molecule *trans* attack is slightly more preferable if compare to *cis*- addition, while in the case of H<sub>2</sub>O and OH<sup>-</sup> one can see the opposite picture.

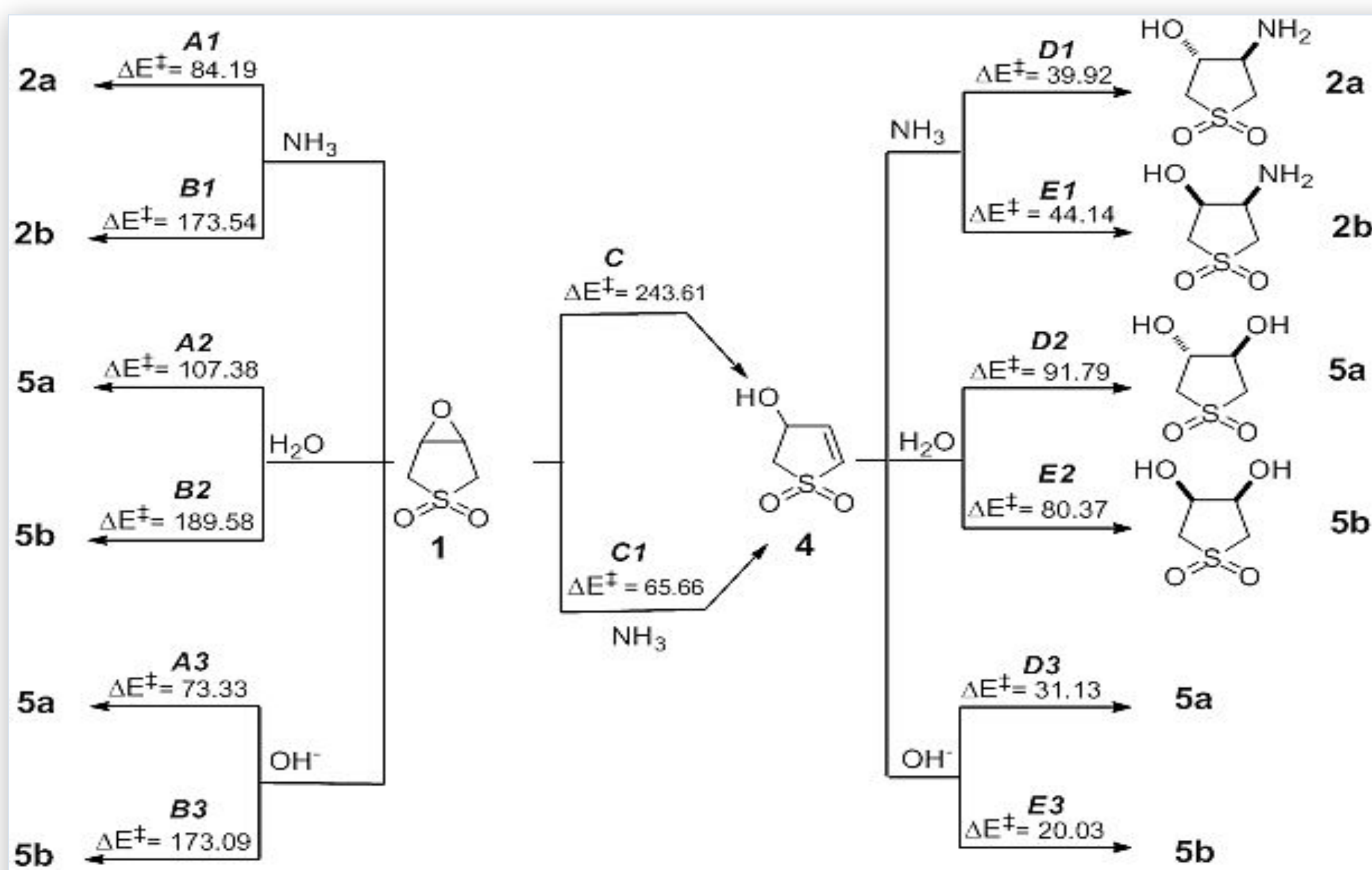

Fig.1. Possible pathways of reaction of 3,4-epoxysulfolane **1** in water solution of ammonia and calculated values of activation energy, kJ/mol

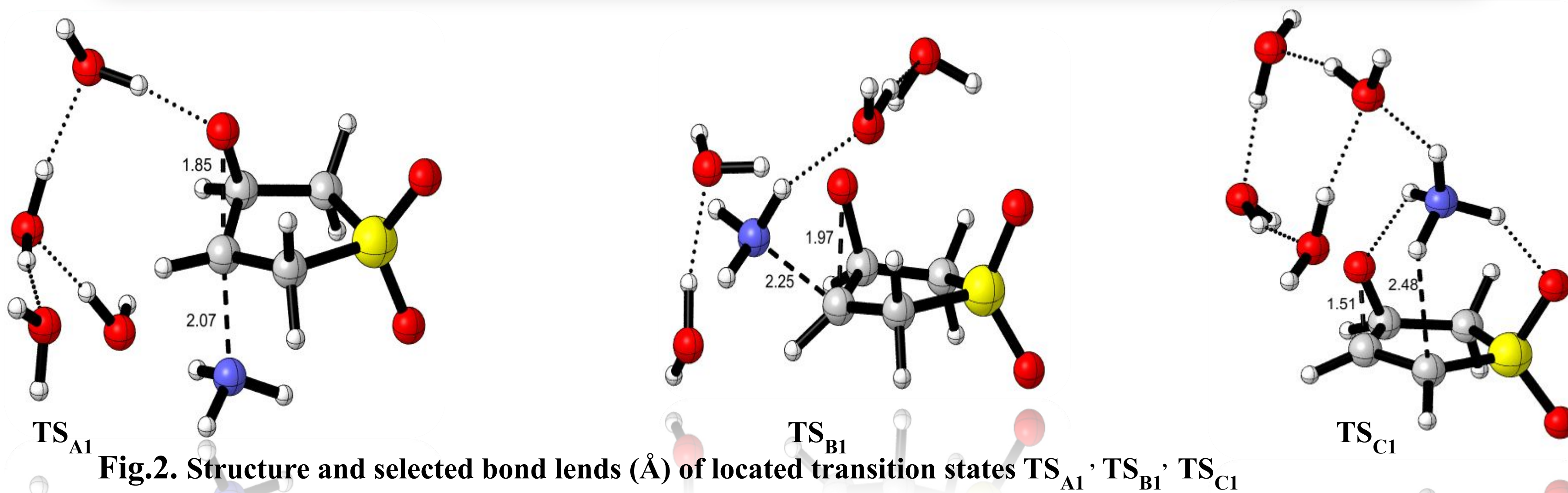

Fig.2. Structure and selected bond lengths (Å) of located transition states TS<sub>A1</sub>, TS<sub>B1</sub>, TS<sub>C1</sub>