

# INTERNAL COMBUSTION ENGINE

Komarov A.A.

---

# Four stroke configuration Operation

1. Intake
2. Compression
3. Power
4. Exhaust

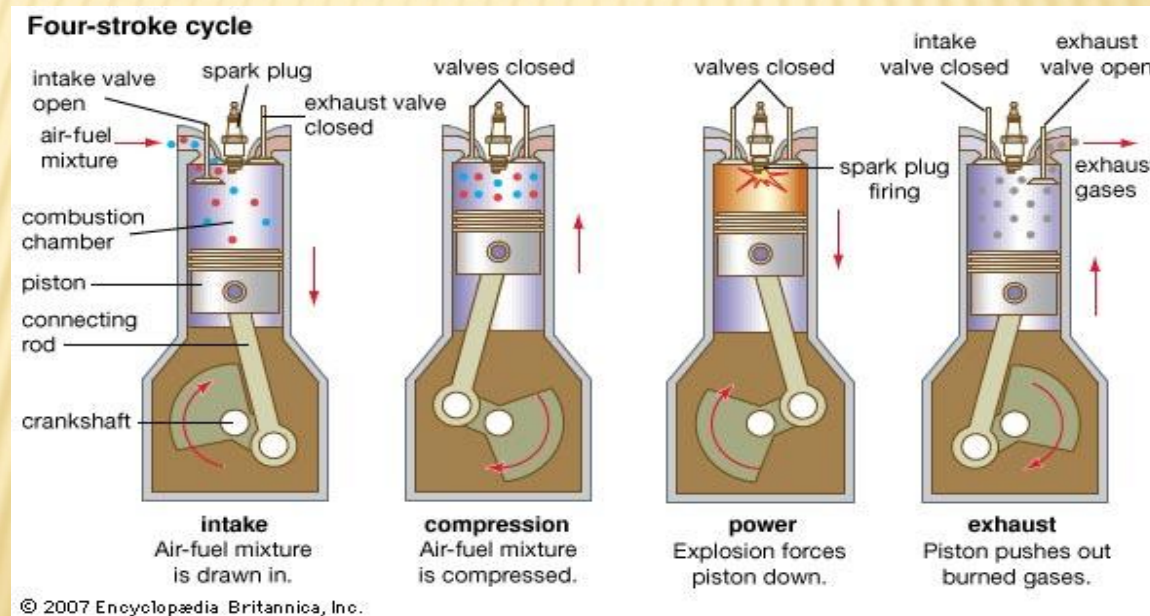

# Parts

An illustration of several key components in a typical four-stroke engine.

Crankshaft (purple).

Connecting rod (orange).

One or more camshafts (red and blue) and valves.

One or more cylinders (grey and green).

Spark plug (darker-grey).

Piston (yellow).

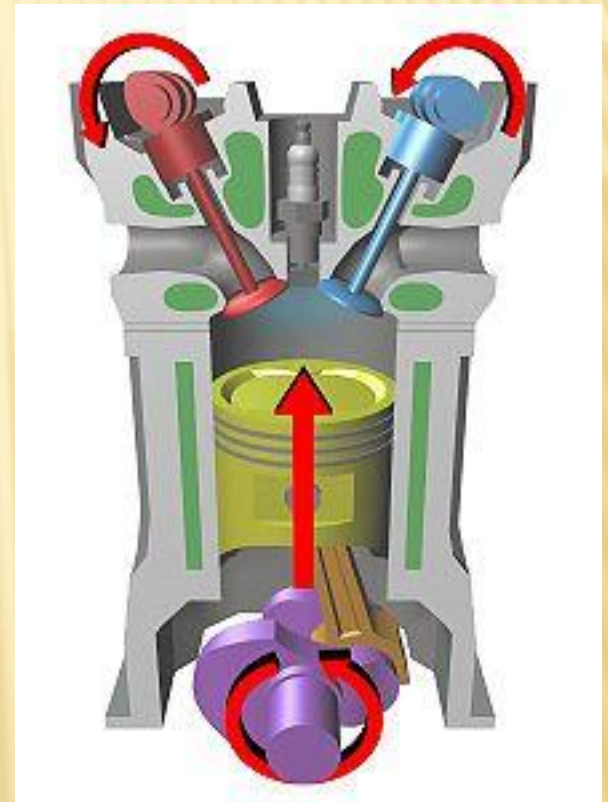



*Types of engine:*

*Inline*

*V*

*Flat (also known as horizontally opposed or boxer).*

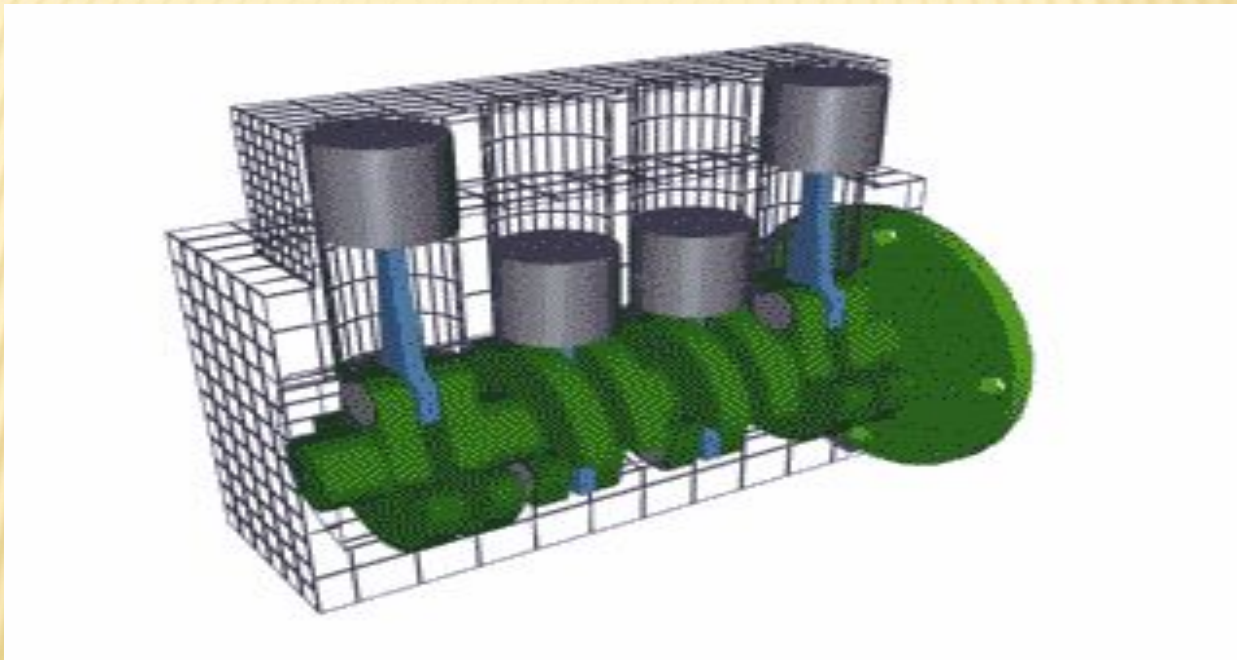

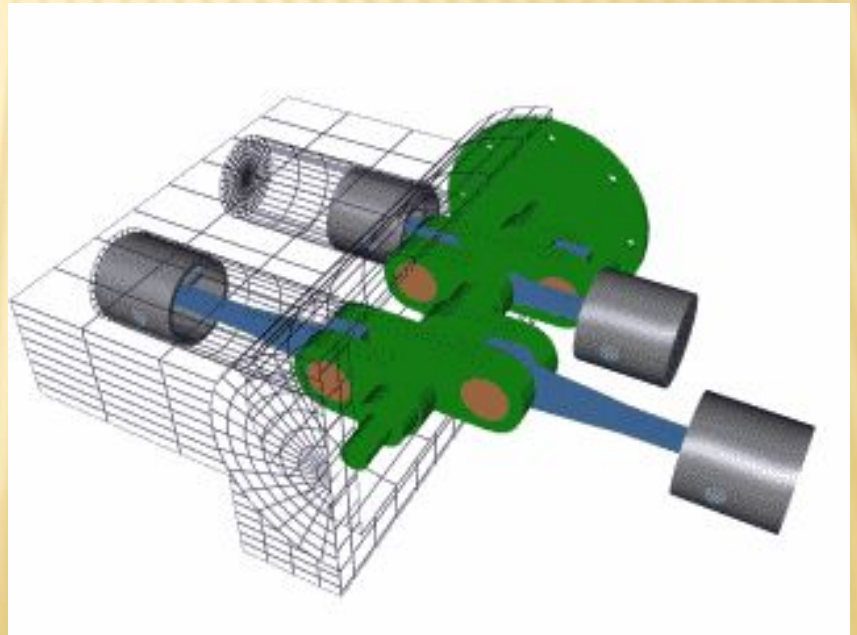
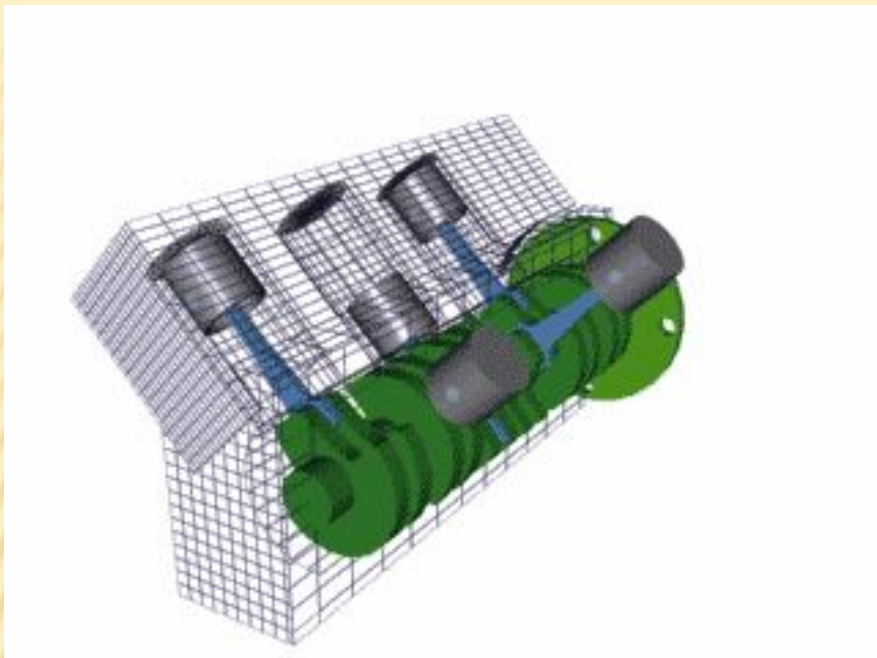

Thank you for your attention!