

а)

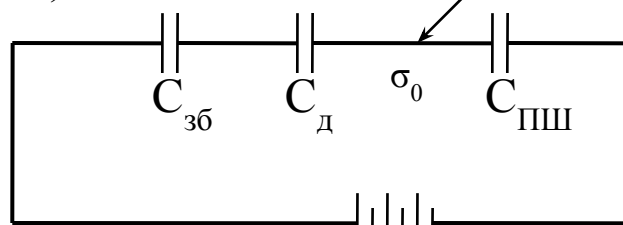

б)

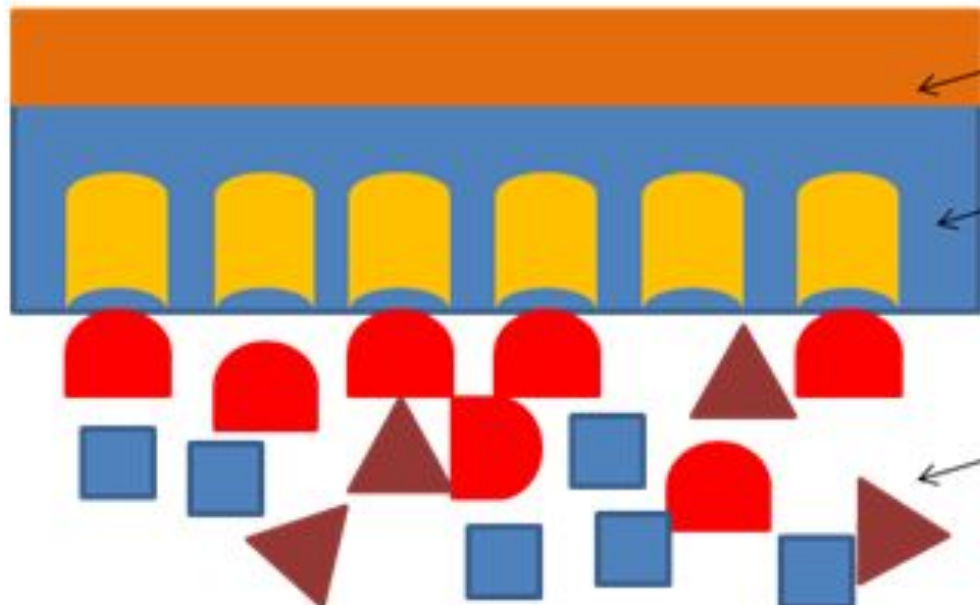

Перетворювач

Шар, що містить
реагенти для специфічного
розпізнавання

Аналіт

MOSFET: What is it and how it works

MOSFET: the **metal–oxide–semiconductor field-effect transistor:**

is a type of transistor used for **amplifying** or **switching electronic signals**.

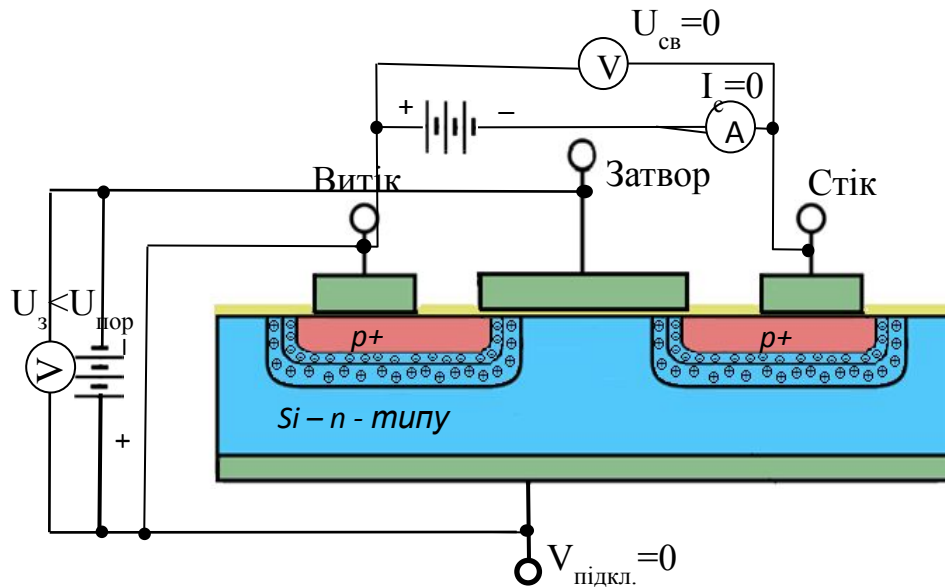

http://www.cleanroom.byu.edu/virtual_cleanroom.parts/MOSFETProcess.html

<https://en.wikipedia.org/wiki/MOSFET>

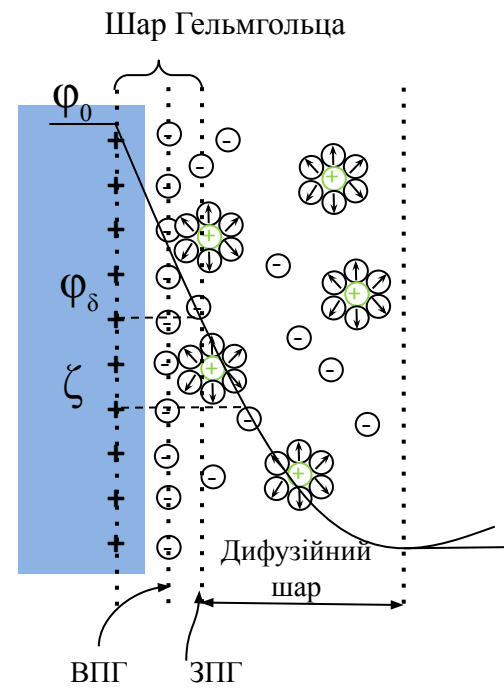
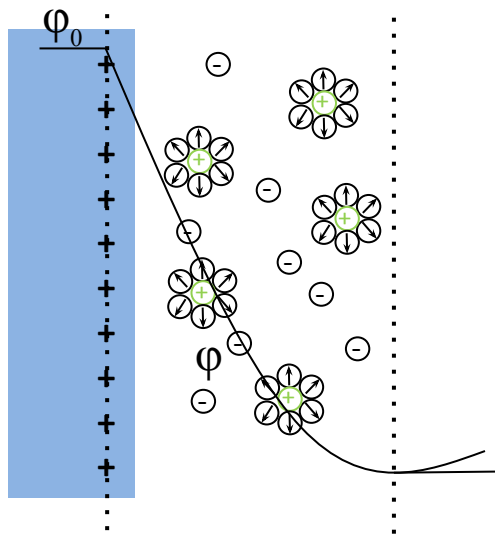
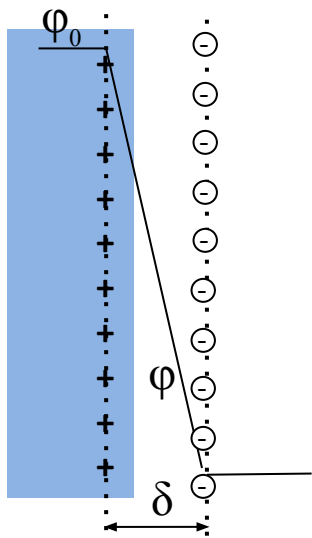

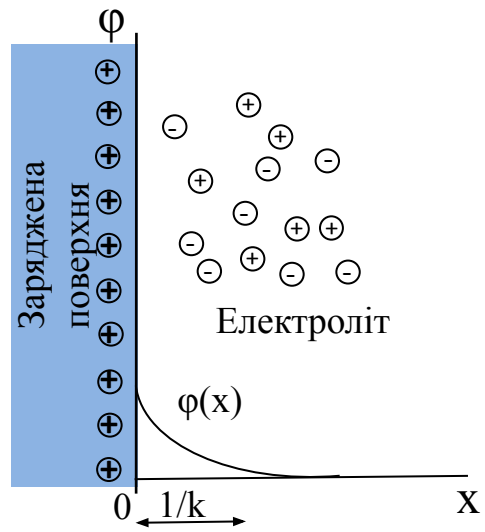

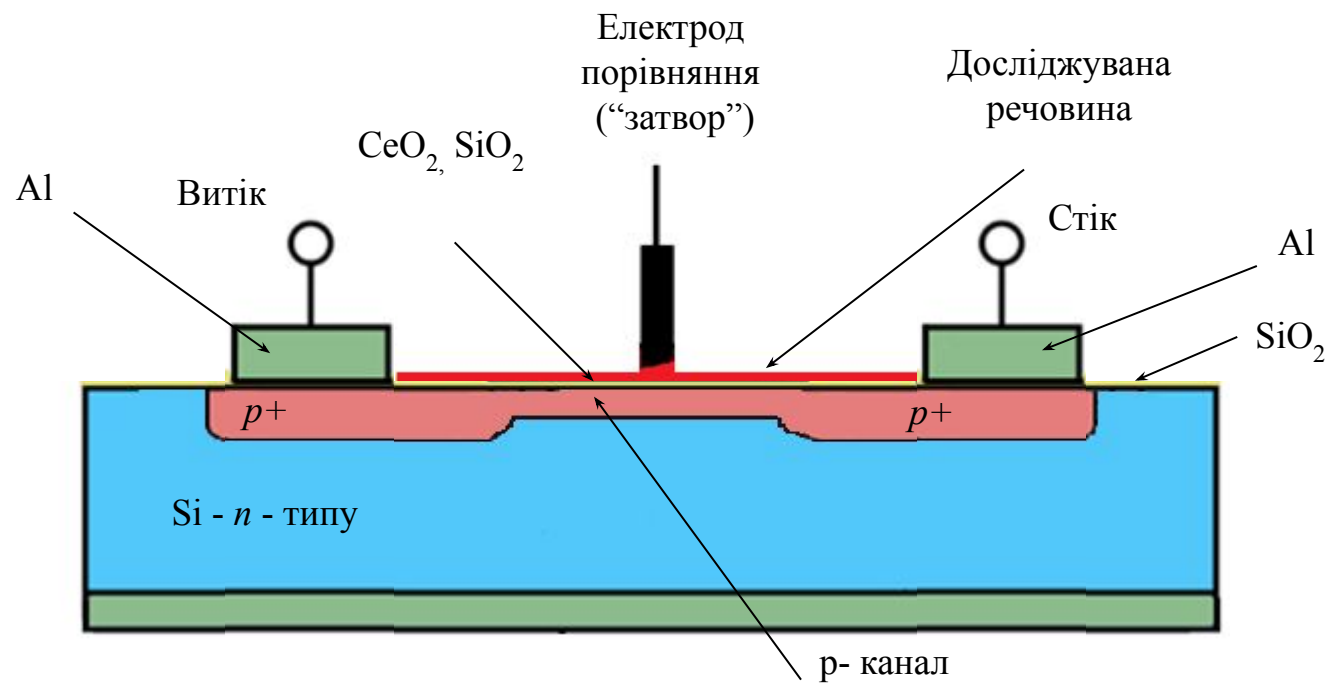

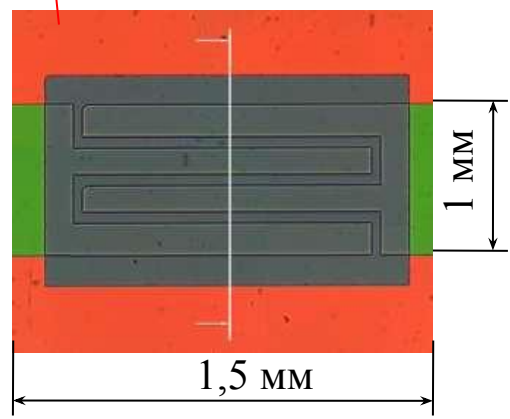
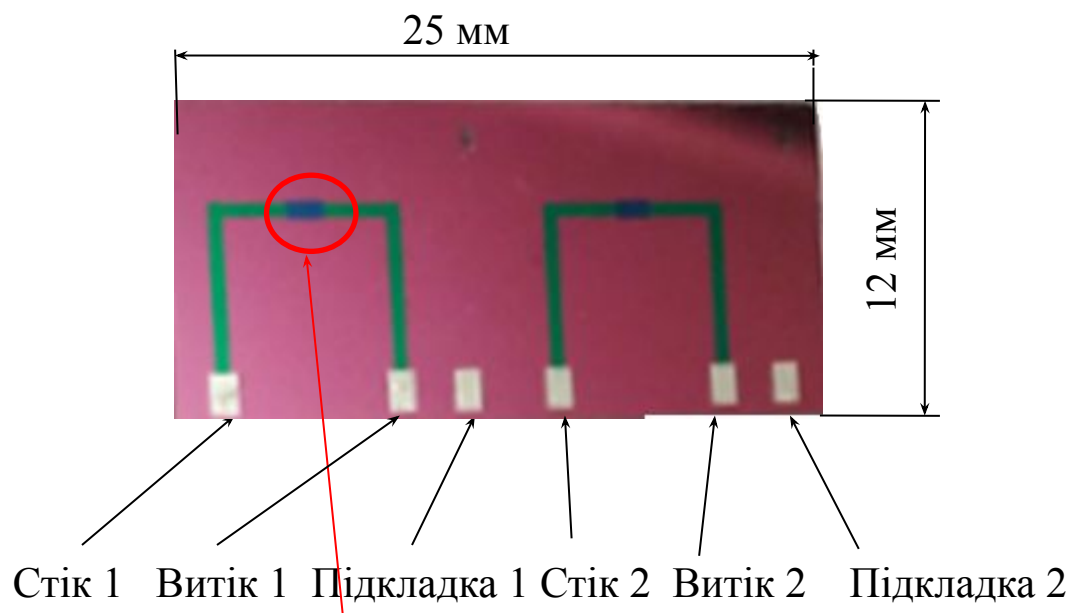

MOSFET: What is it and how it works

MOSFET: the **metal–oxide–semiconductor field-effect transistor:**

is a type of transistor used for **amplifying** or **switching electronic signals**.

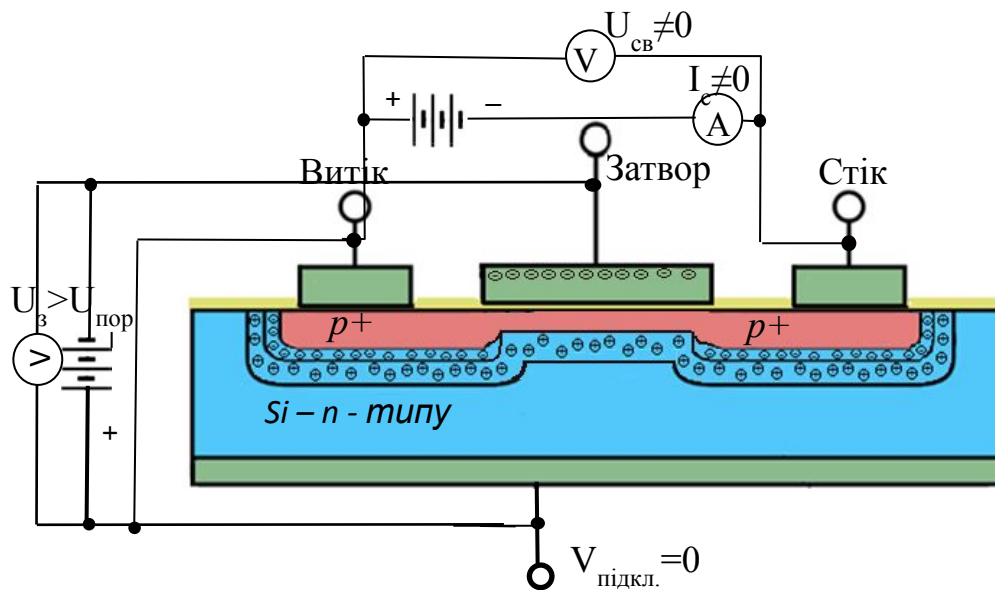

http://www.cleanroom.byu.edu/virtual_cleanroom.parts/MOSFETProcess.html

<https://en.wikipedia.org/wiki/MOSFET>

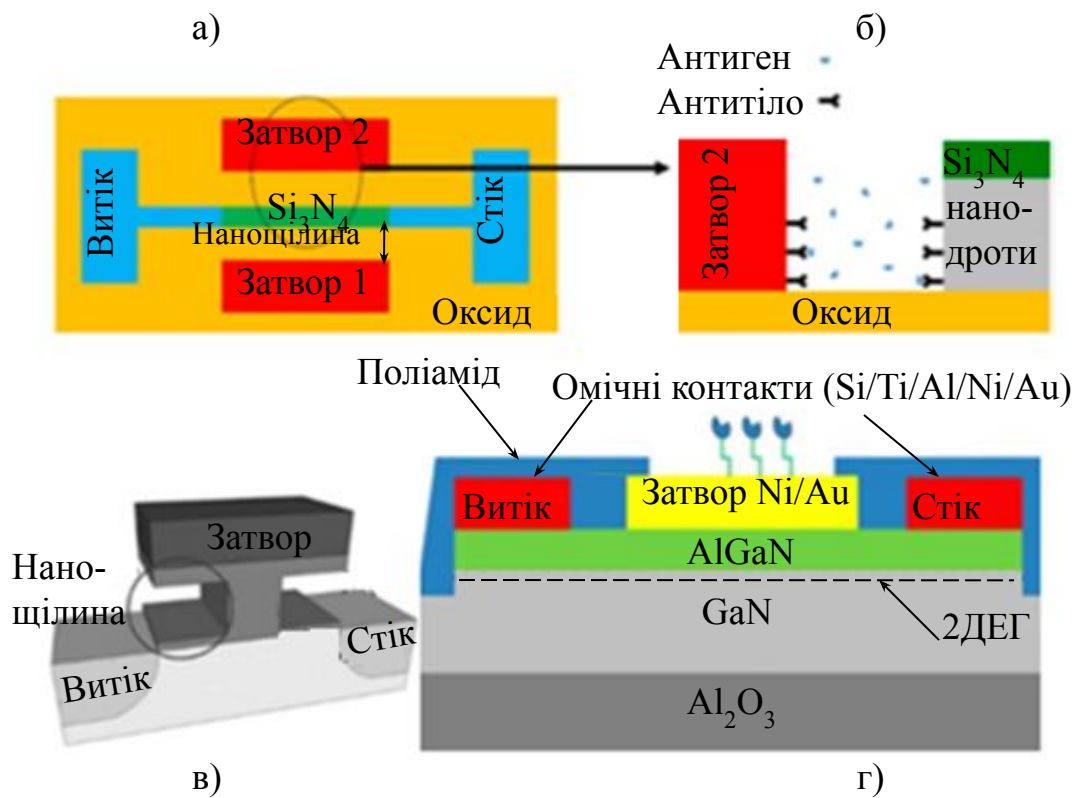

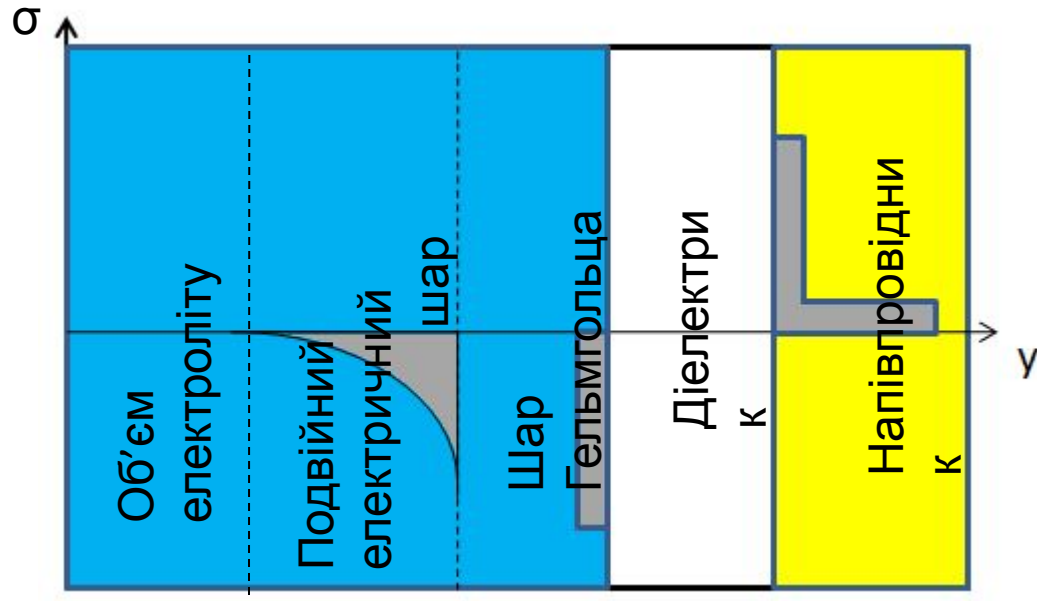

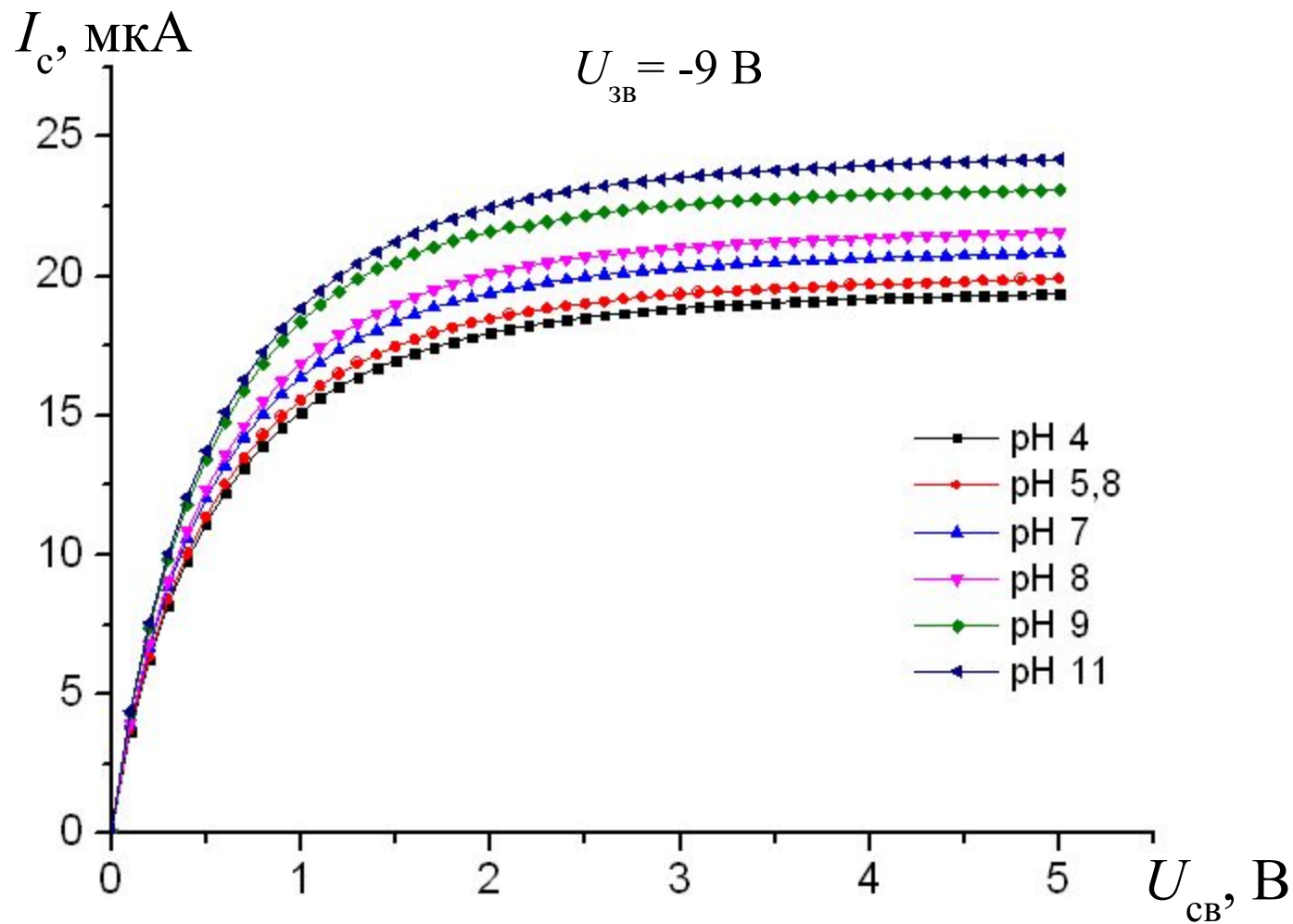

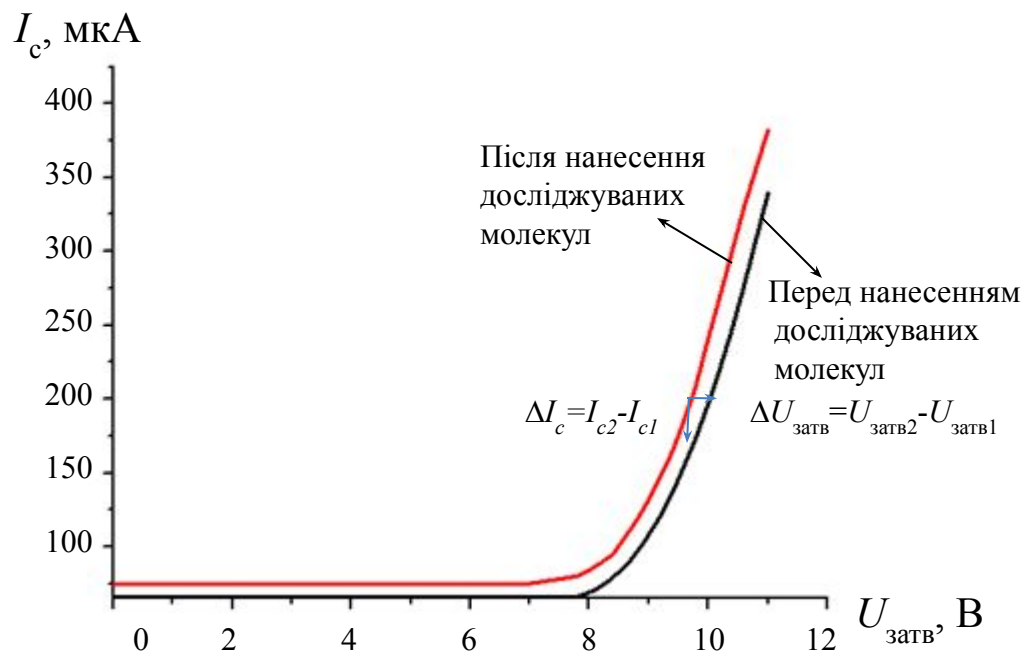
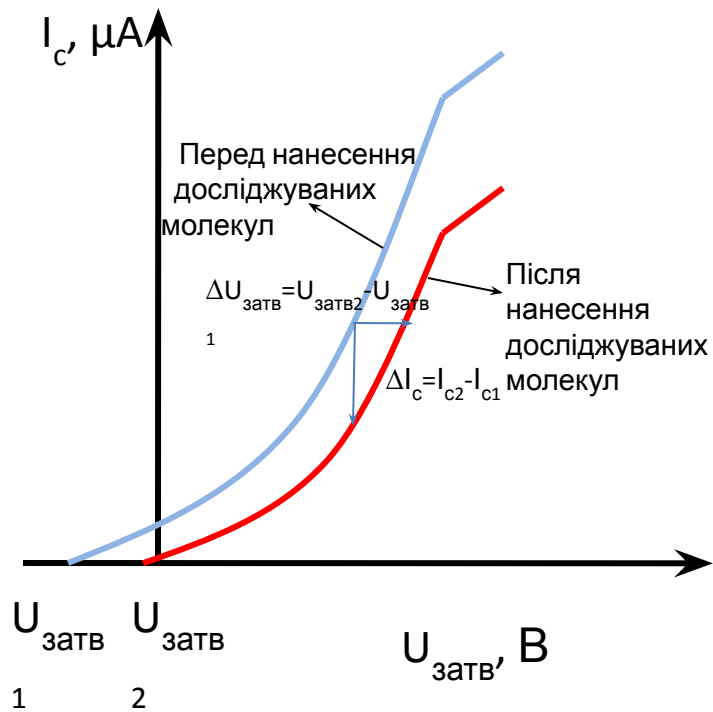

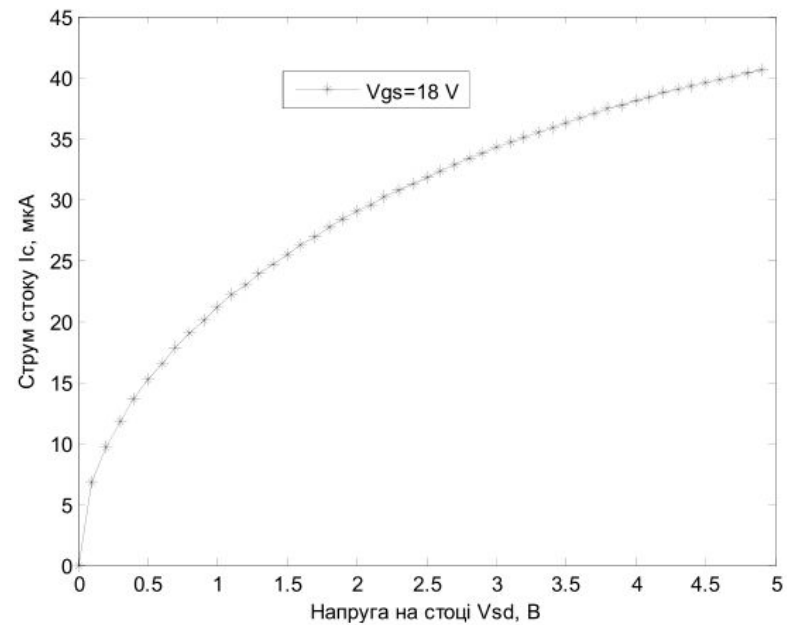
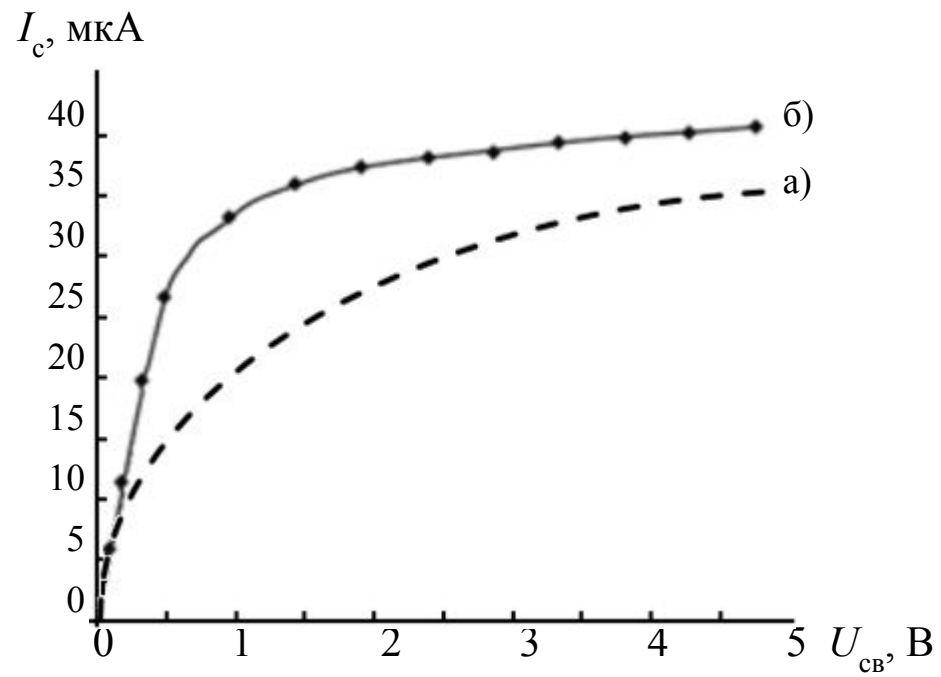

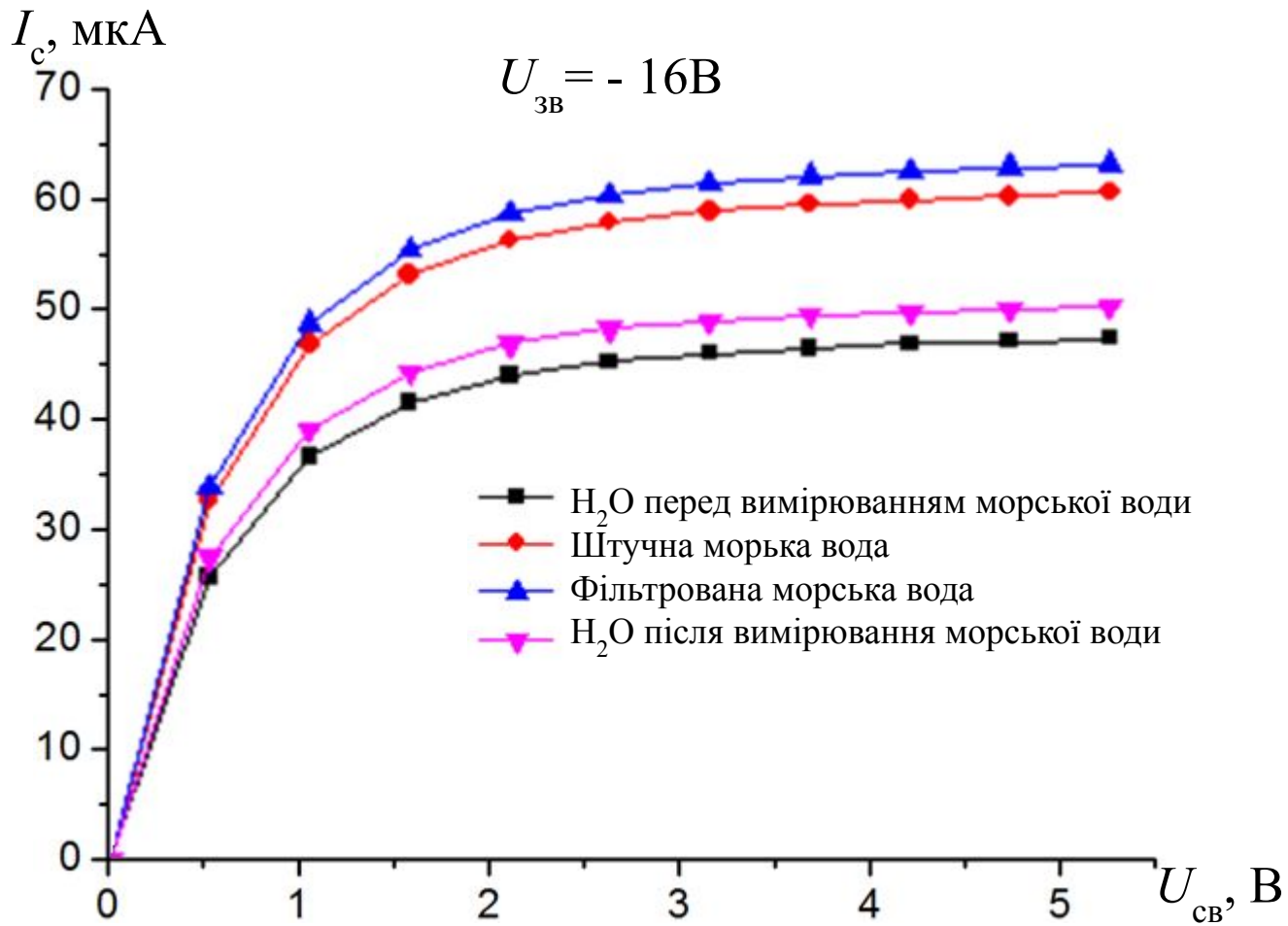

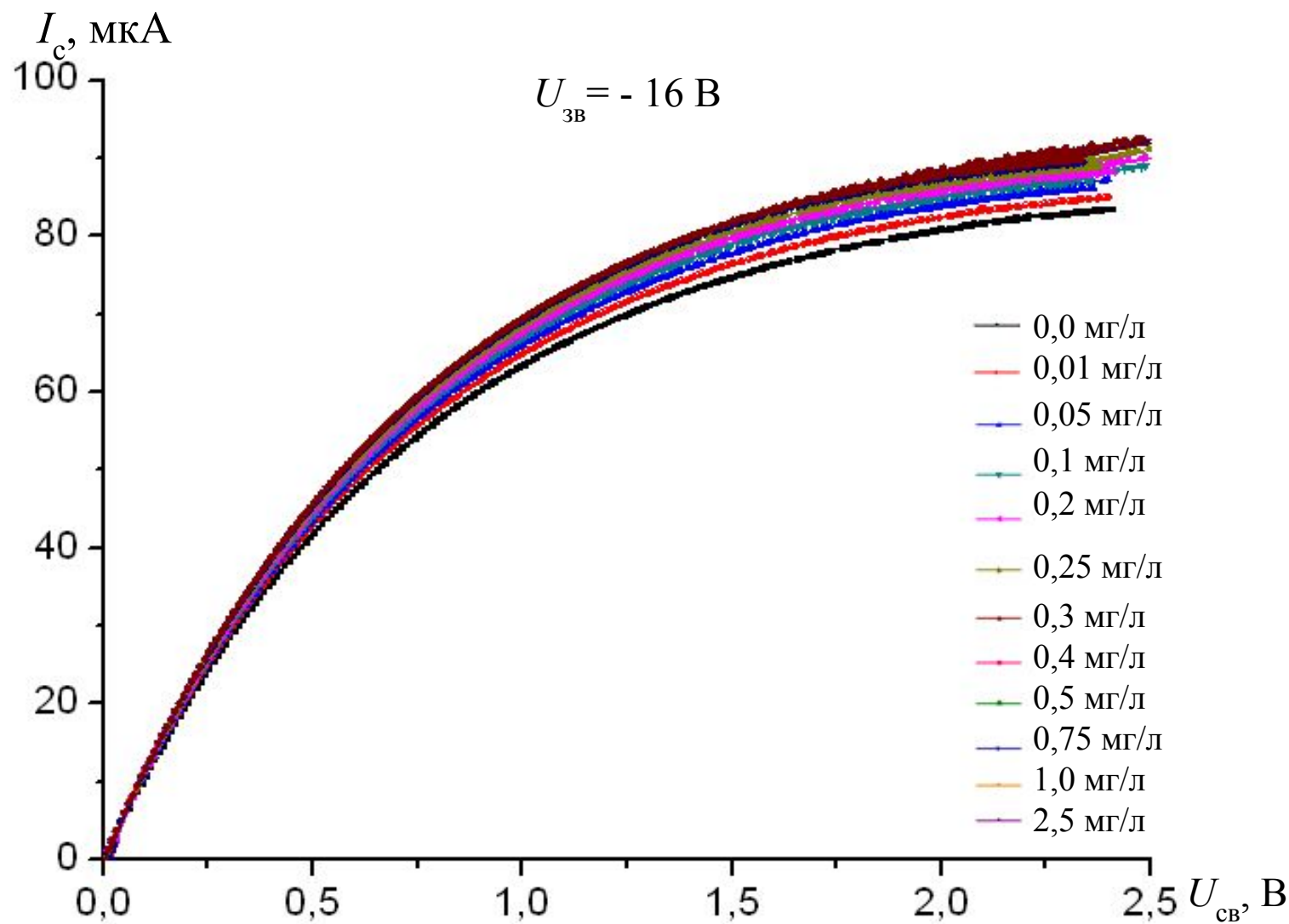

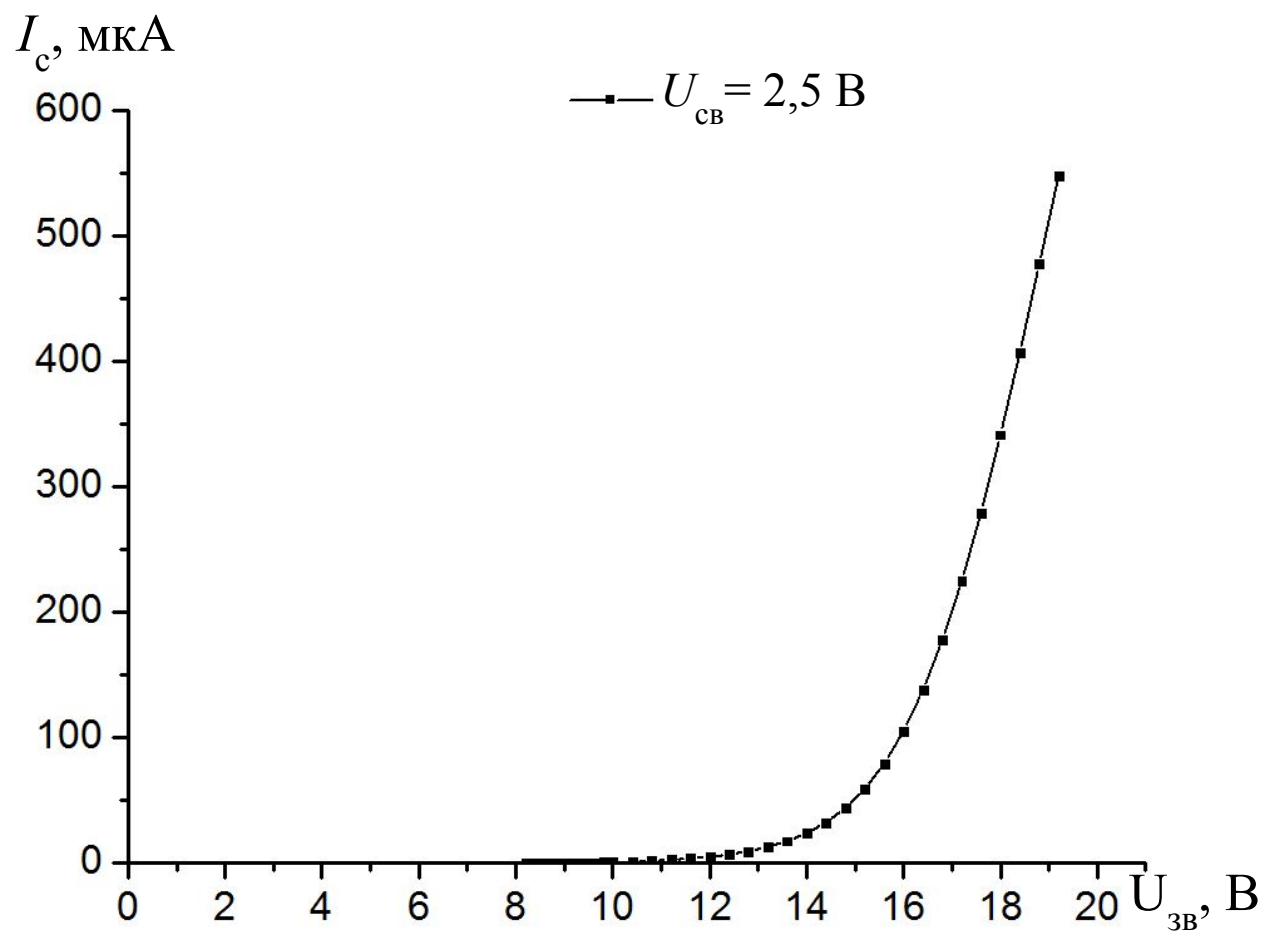

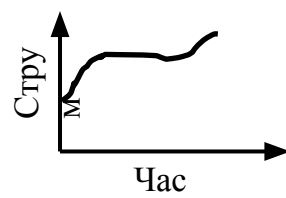
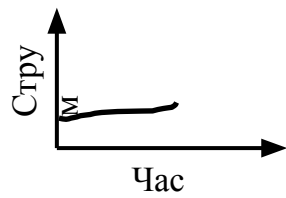
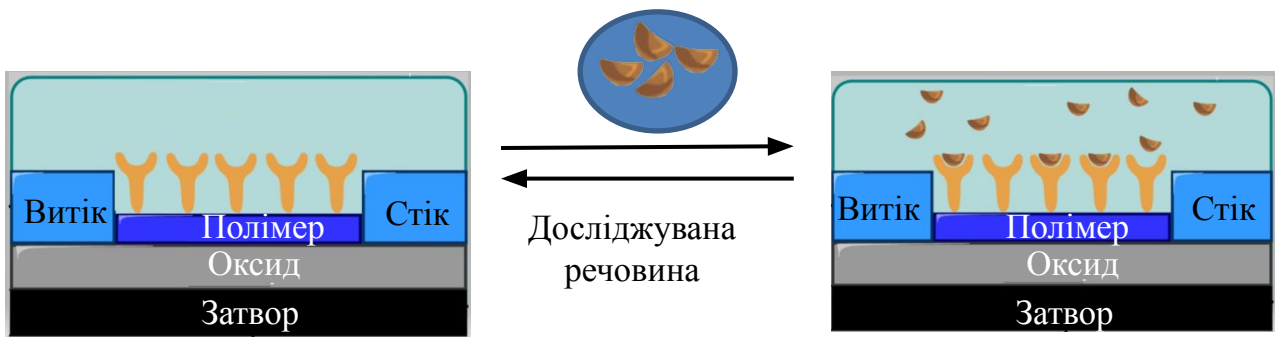

$U_{3B}(C) - U_{3B}(0), B$

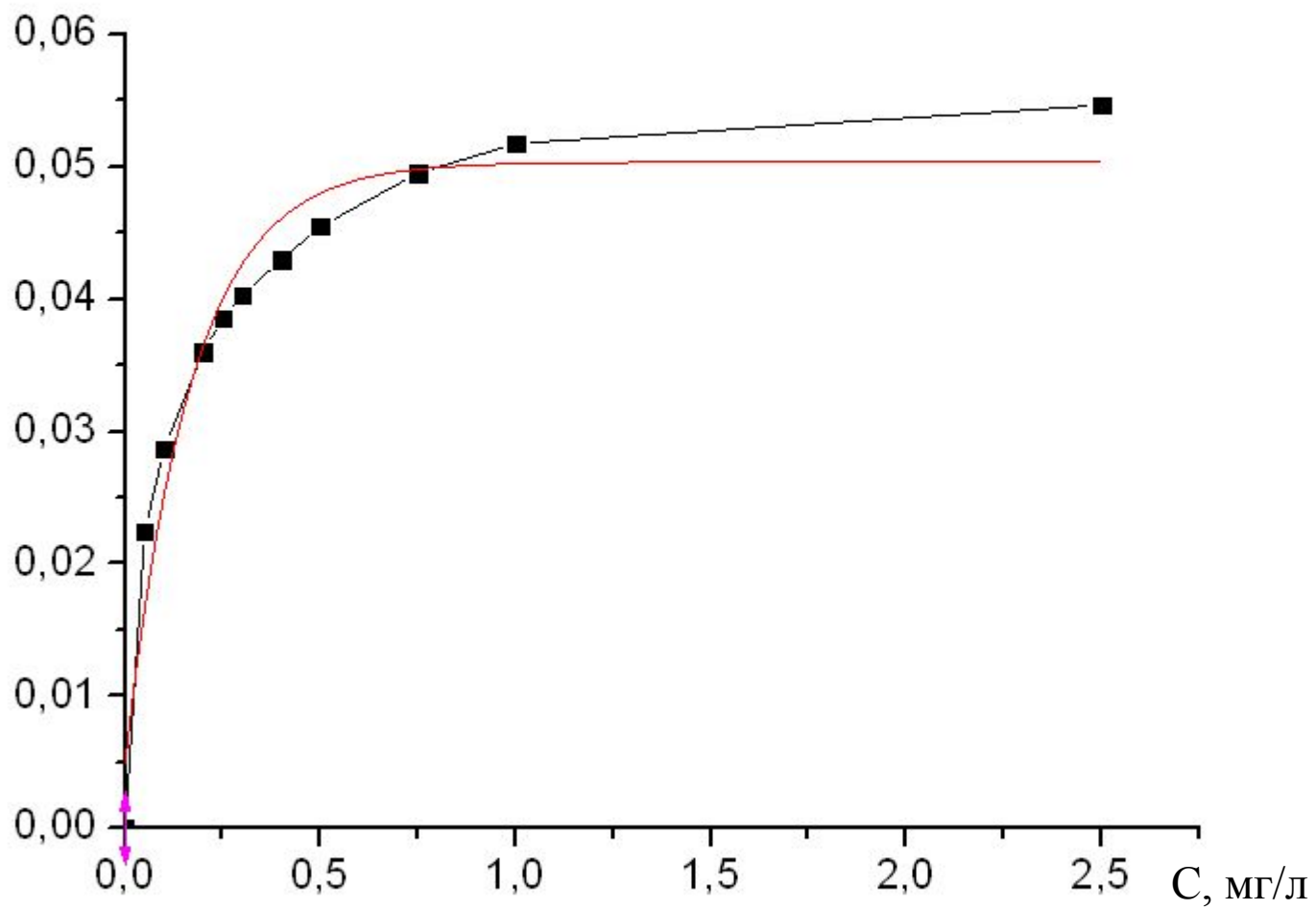

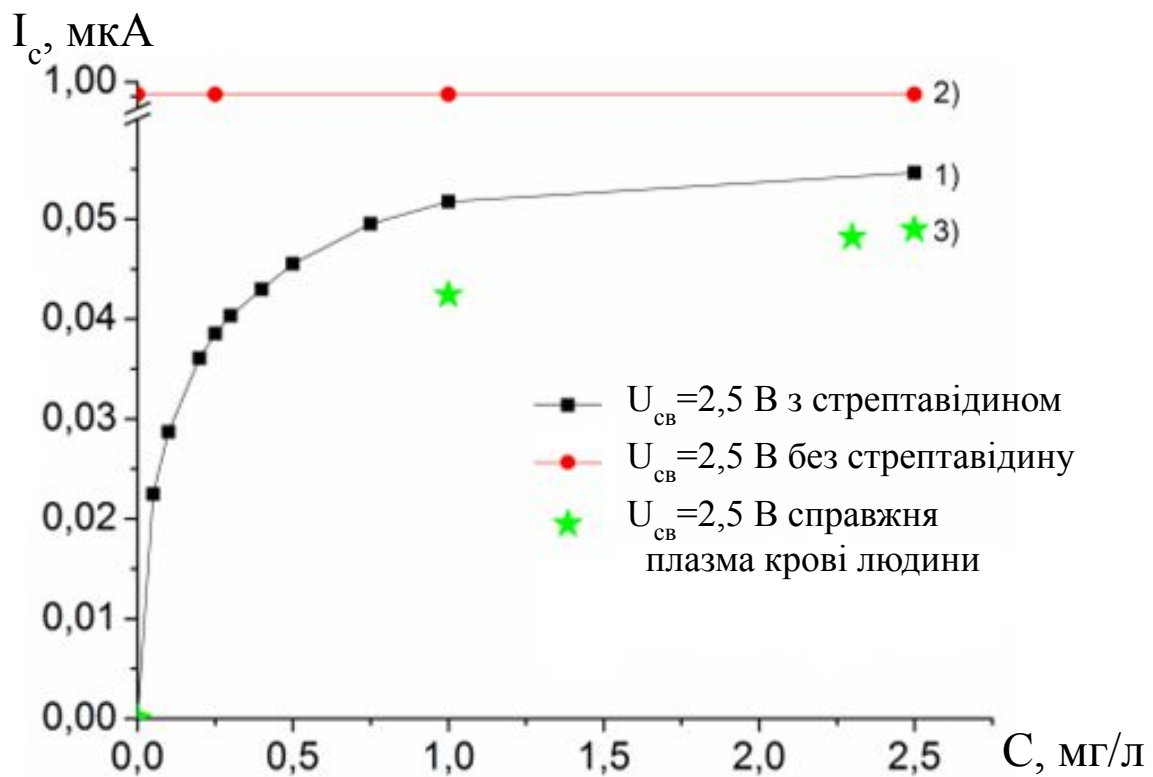

Зовнішня
площина
Гельмгольца

Позитивно
заряджені іони

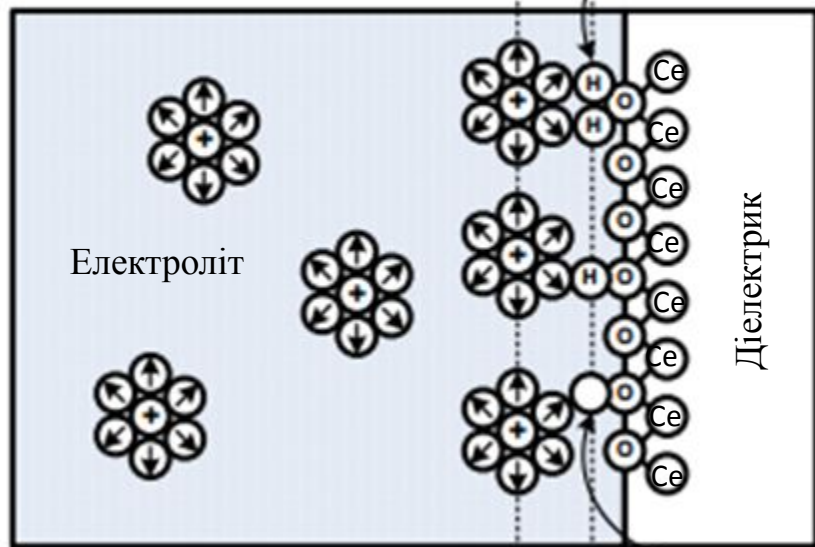

Електроліт

Діелектрик

Дифузійний шар

Шар
Гельмгольца

Негативно
заряджені іони

Зовнішня
площина
Гельмгольца

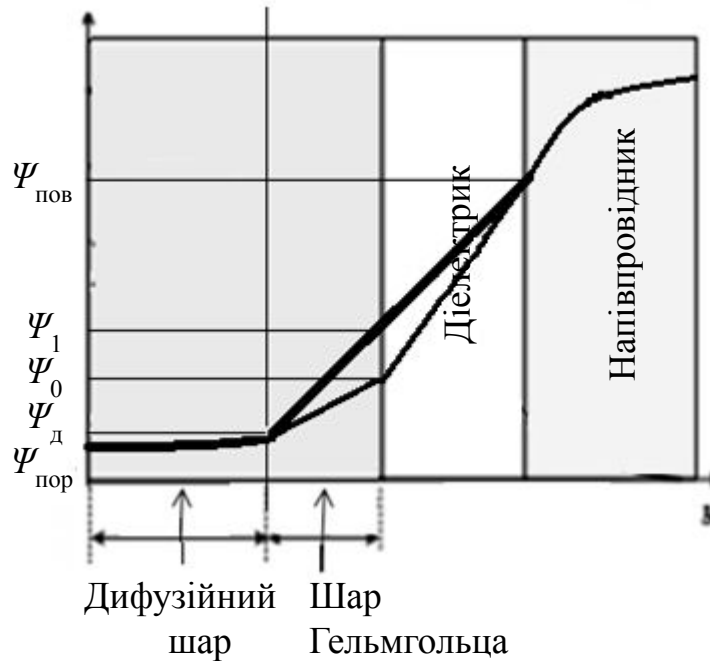

$\Psi_{пов}$

Ψ_1

Ψ_0

$\Psi_д$

$\Psi_{пор}$

Дифузійний
шар

Шар
Гельмгольца

Діелектрик

Напівпровідник

I_c , μA

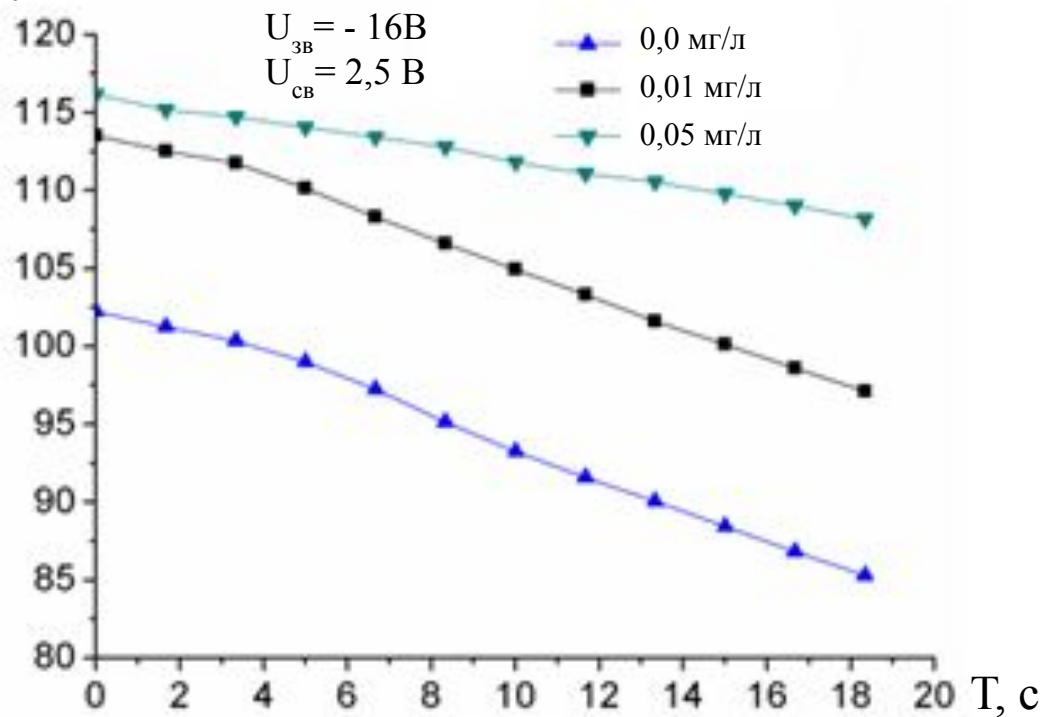

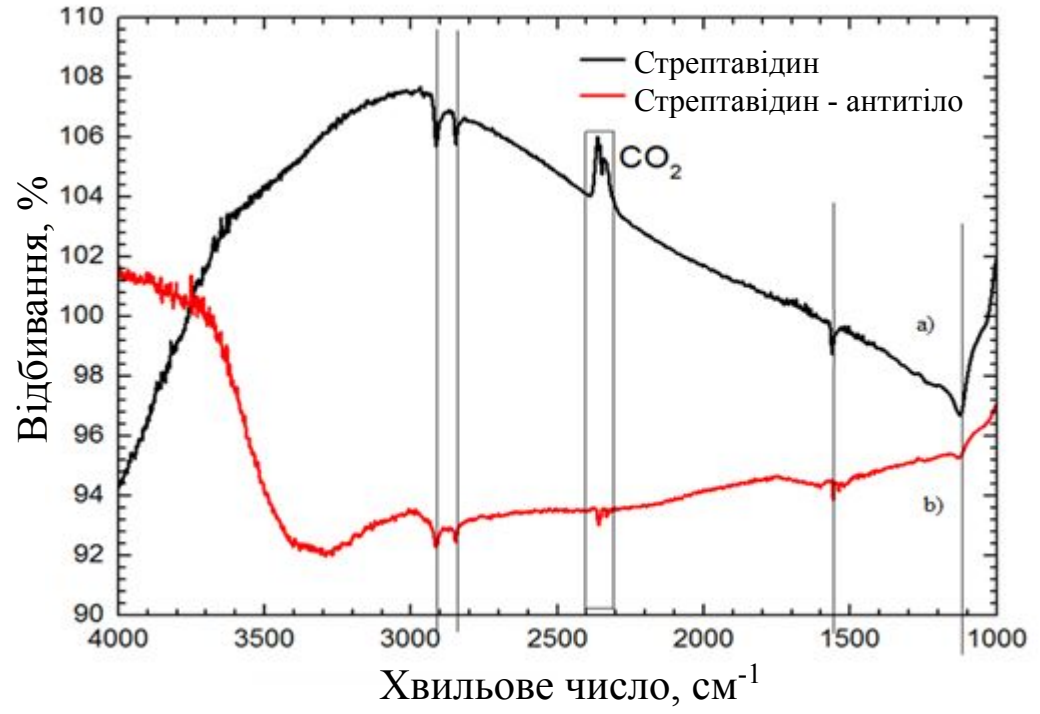

I_c , μA

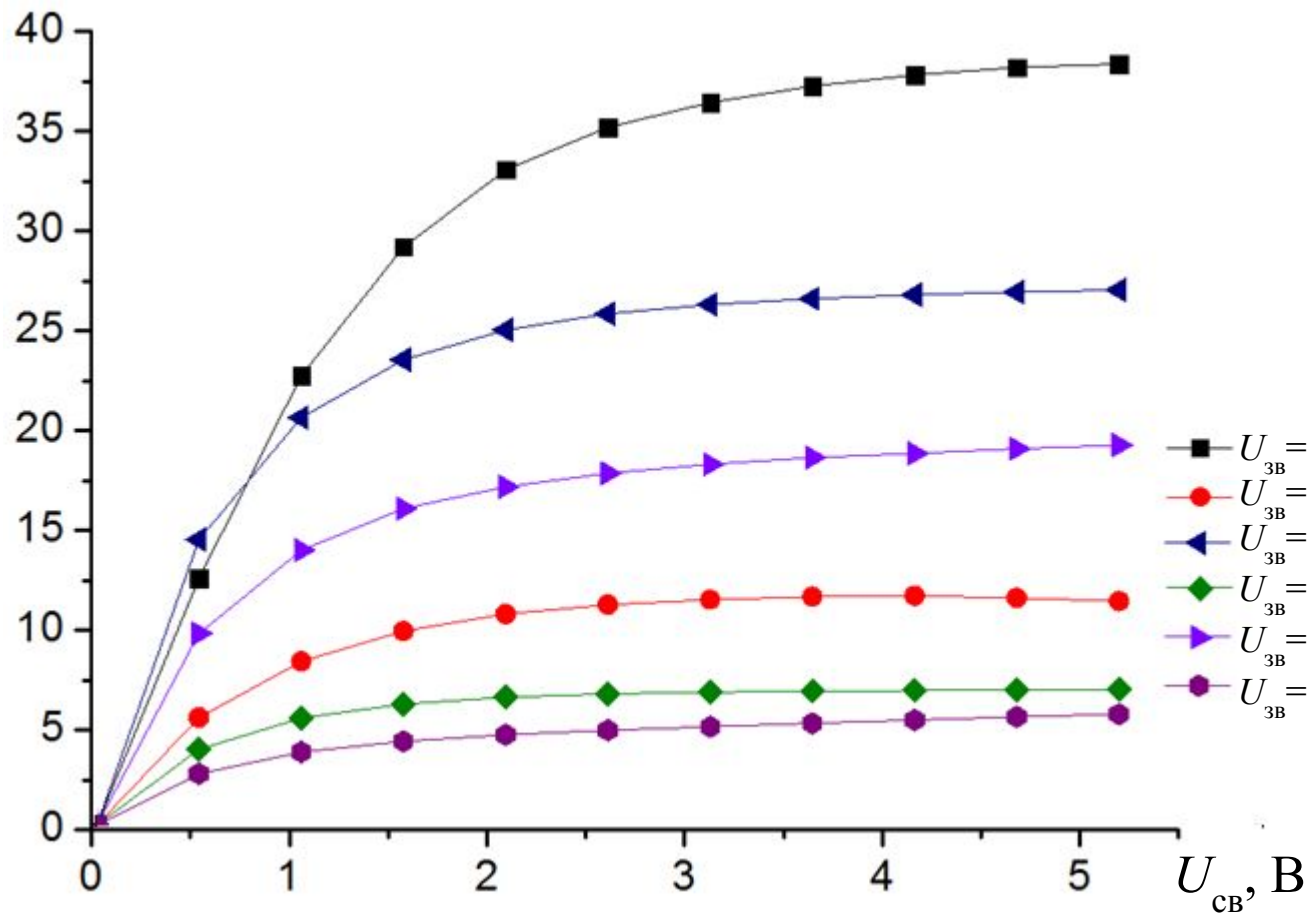

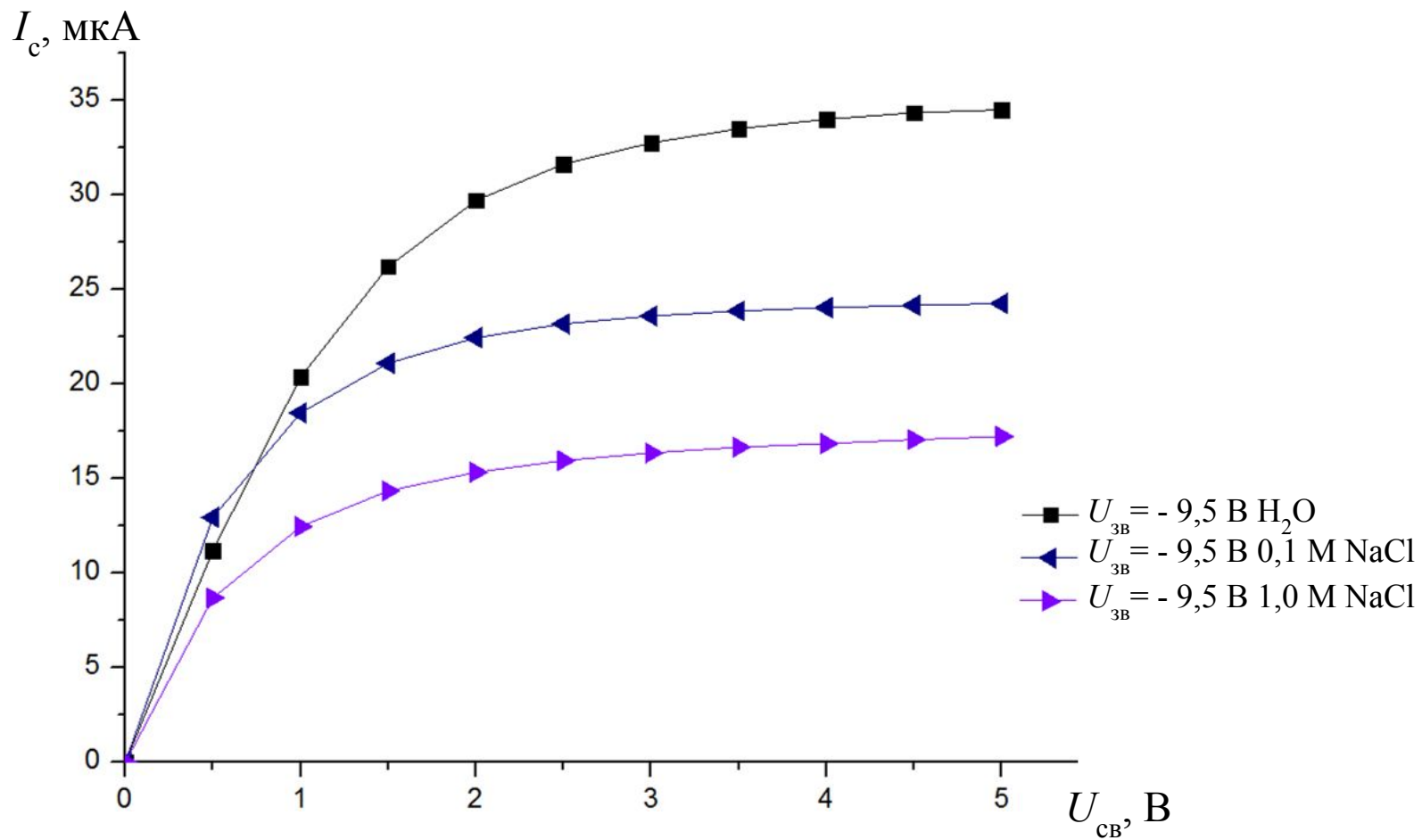

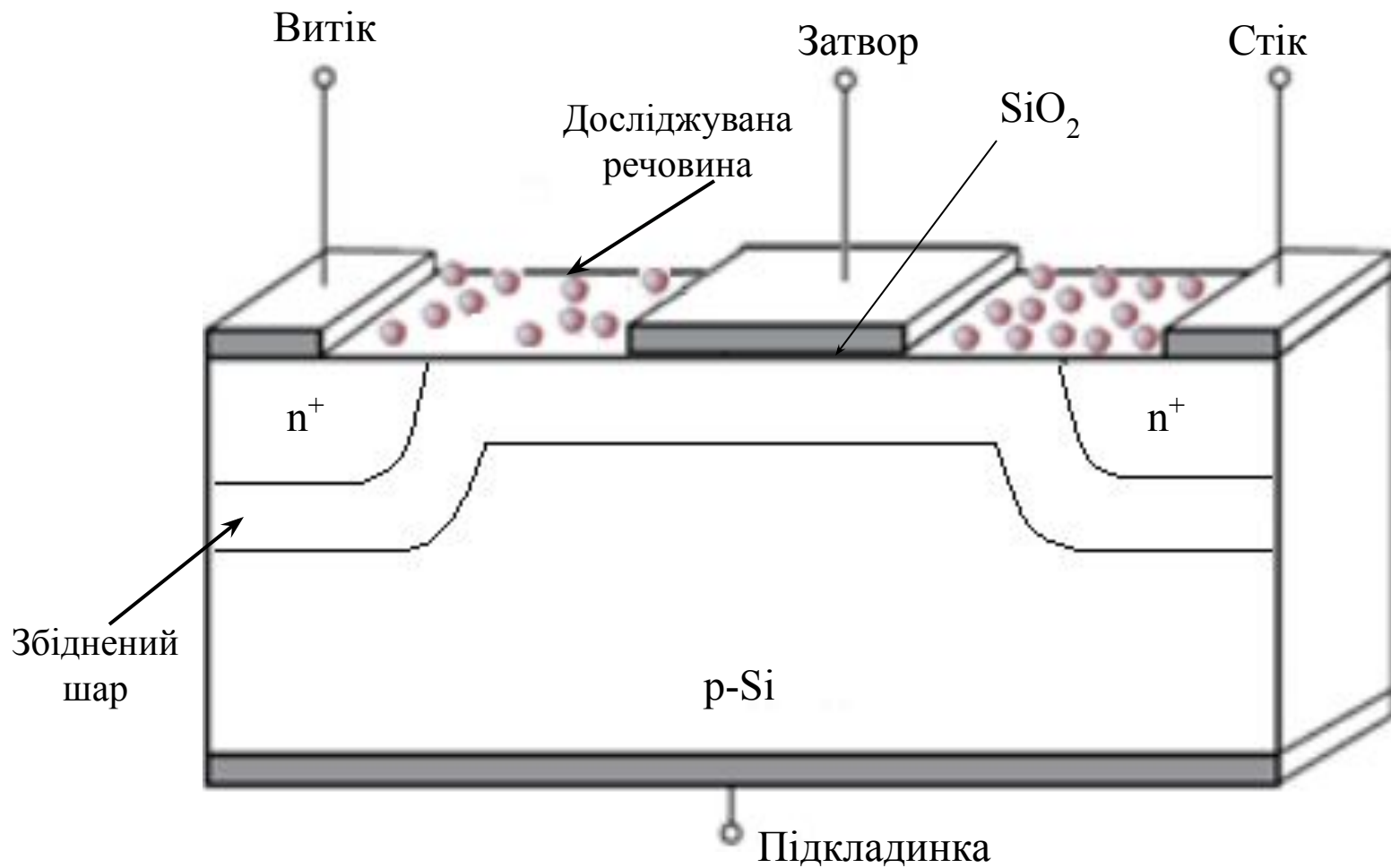

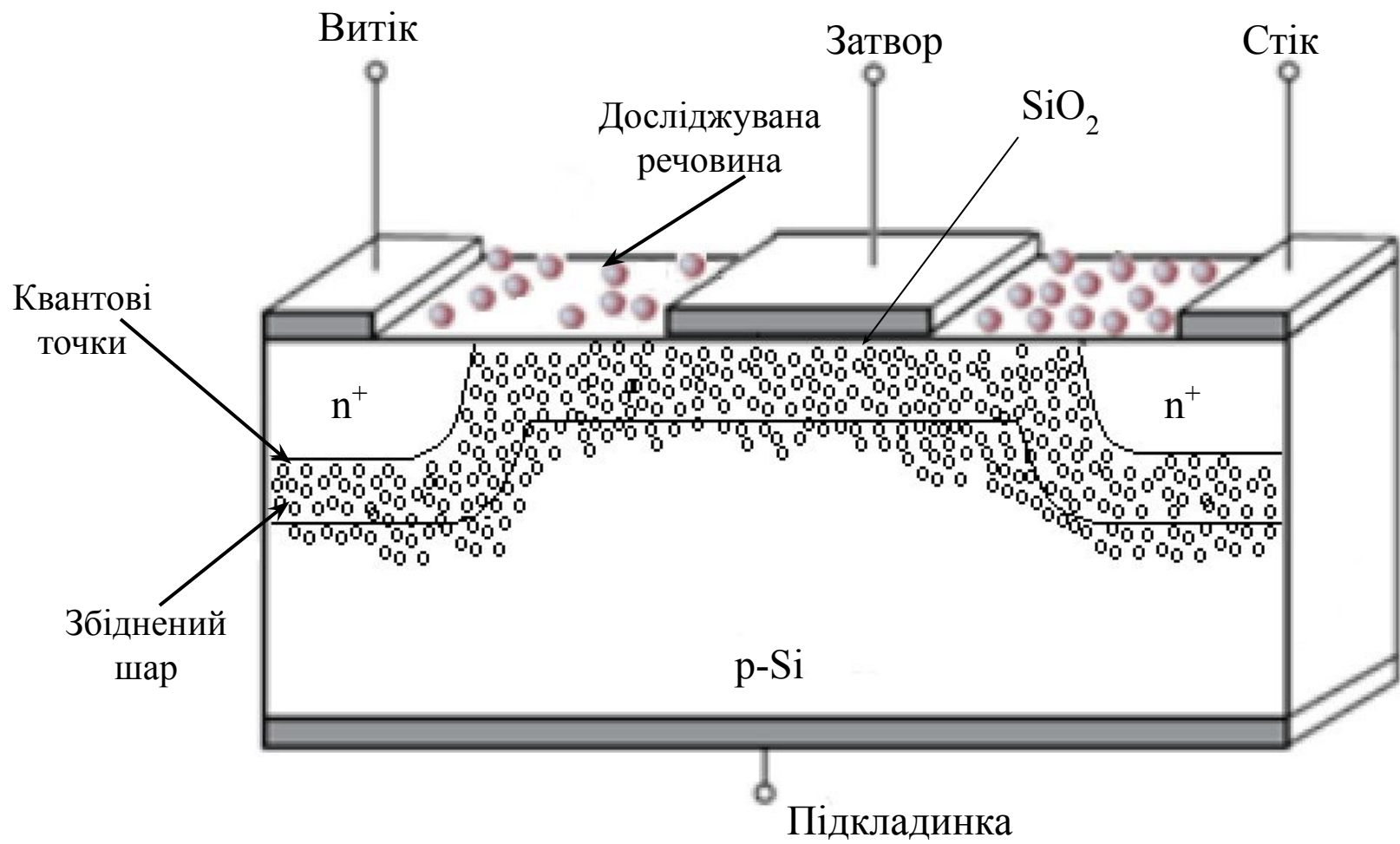

I_c , мкА

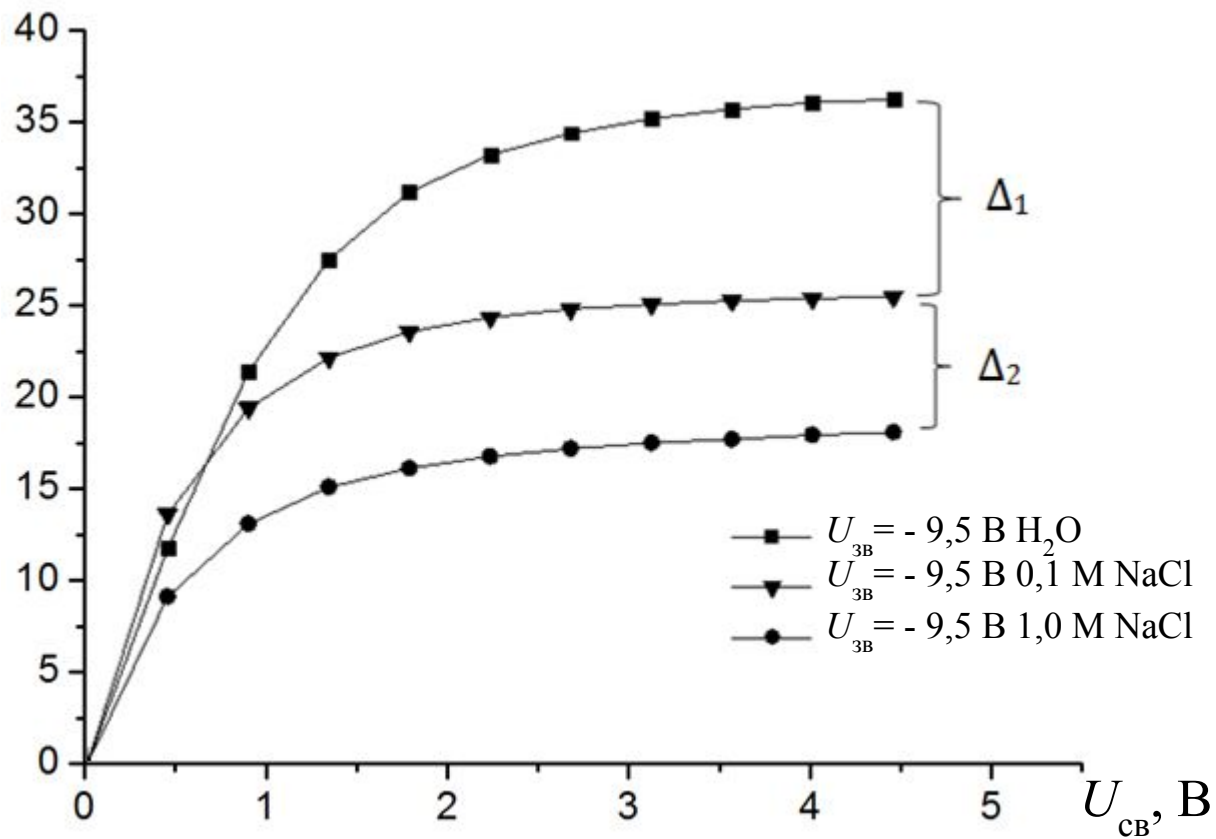

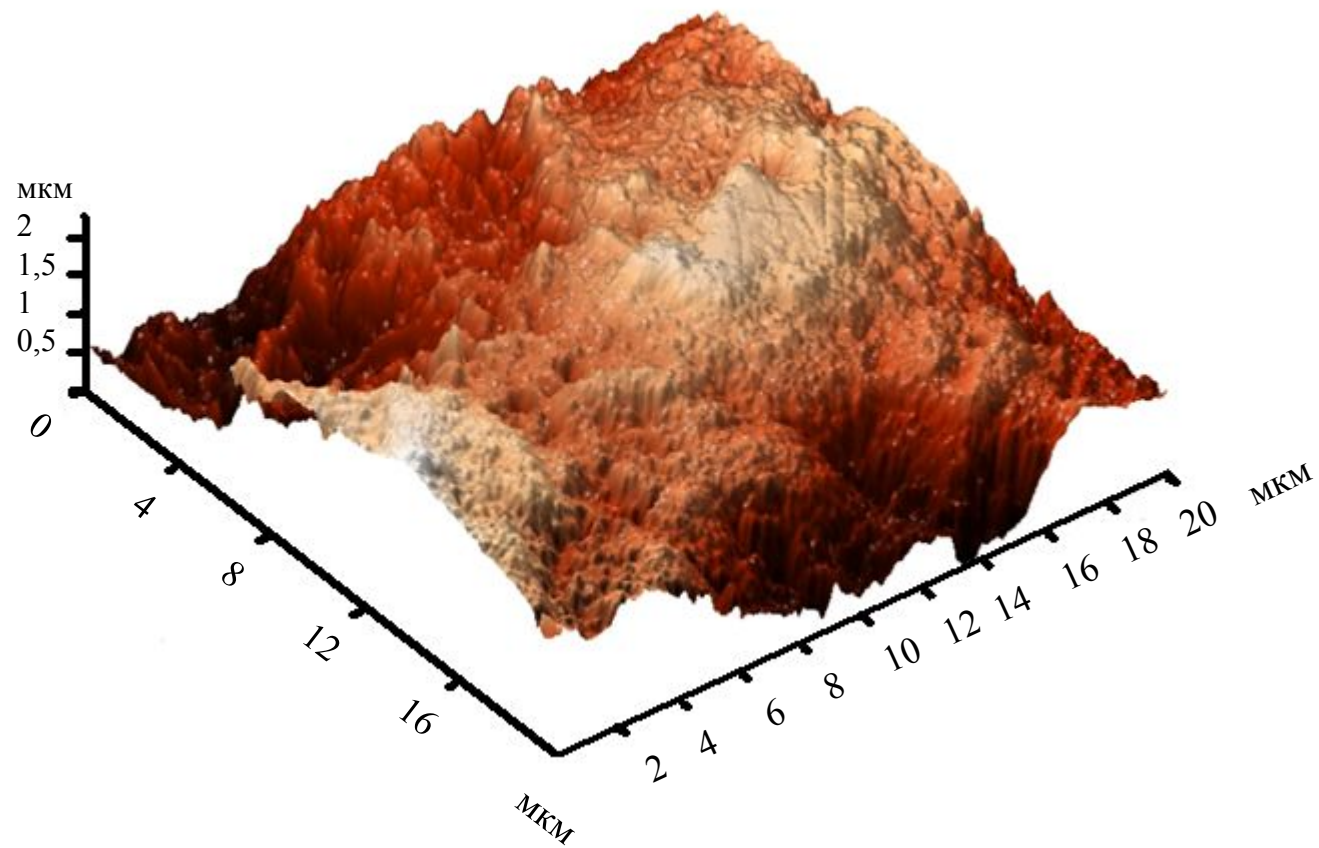

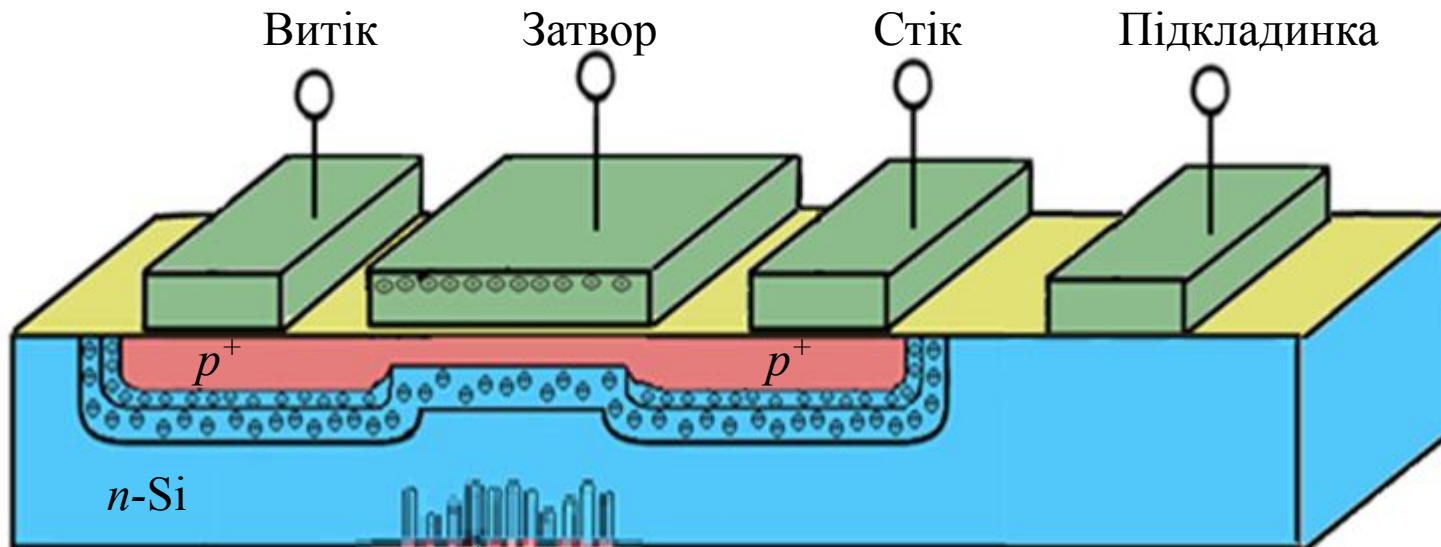

Пориста структура
з Pt наночастинками

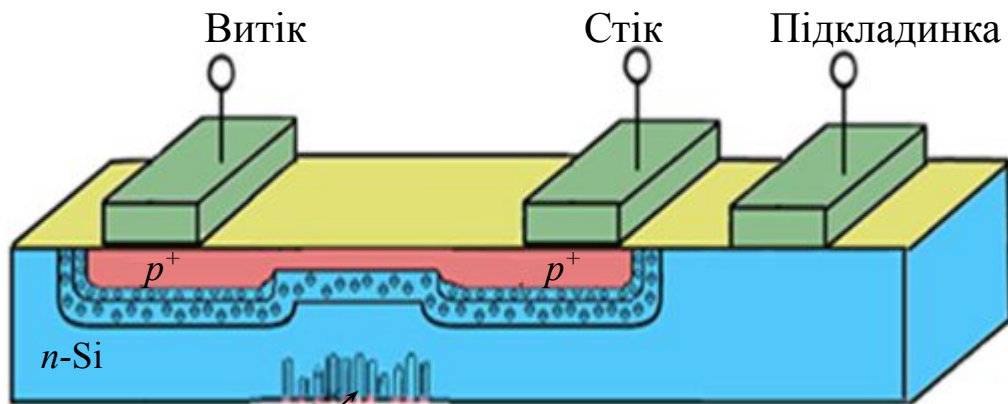

Пориста структура
з Pt наночастинками

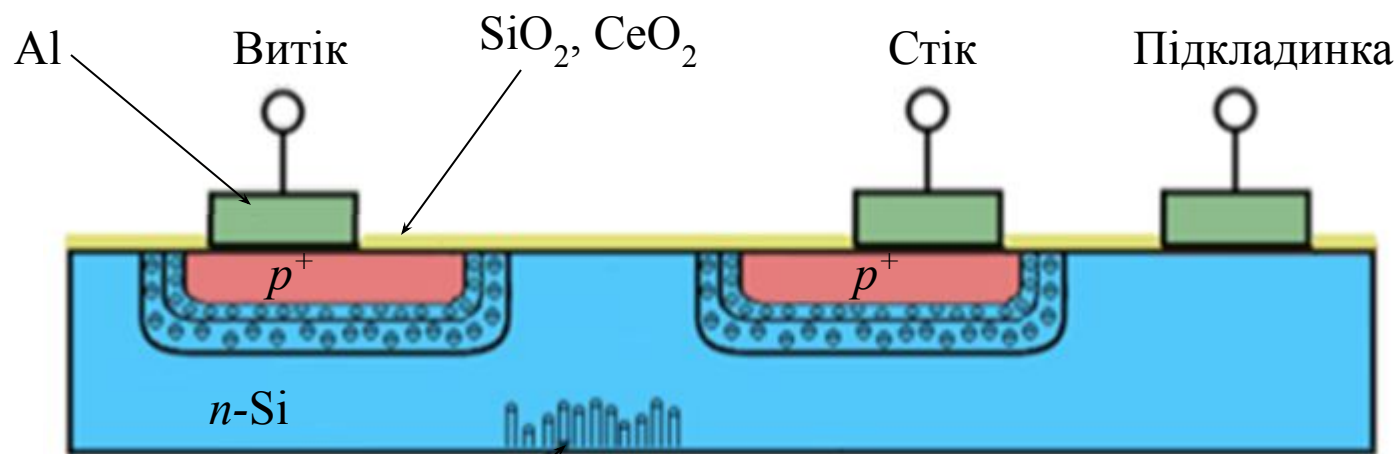

Пориста структура
з Pt наночастинками

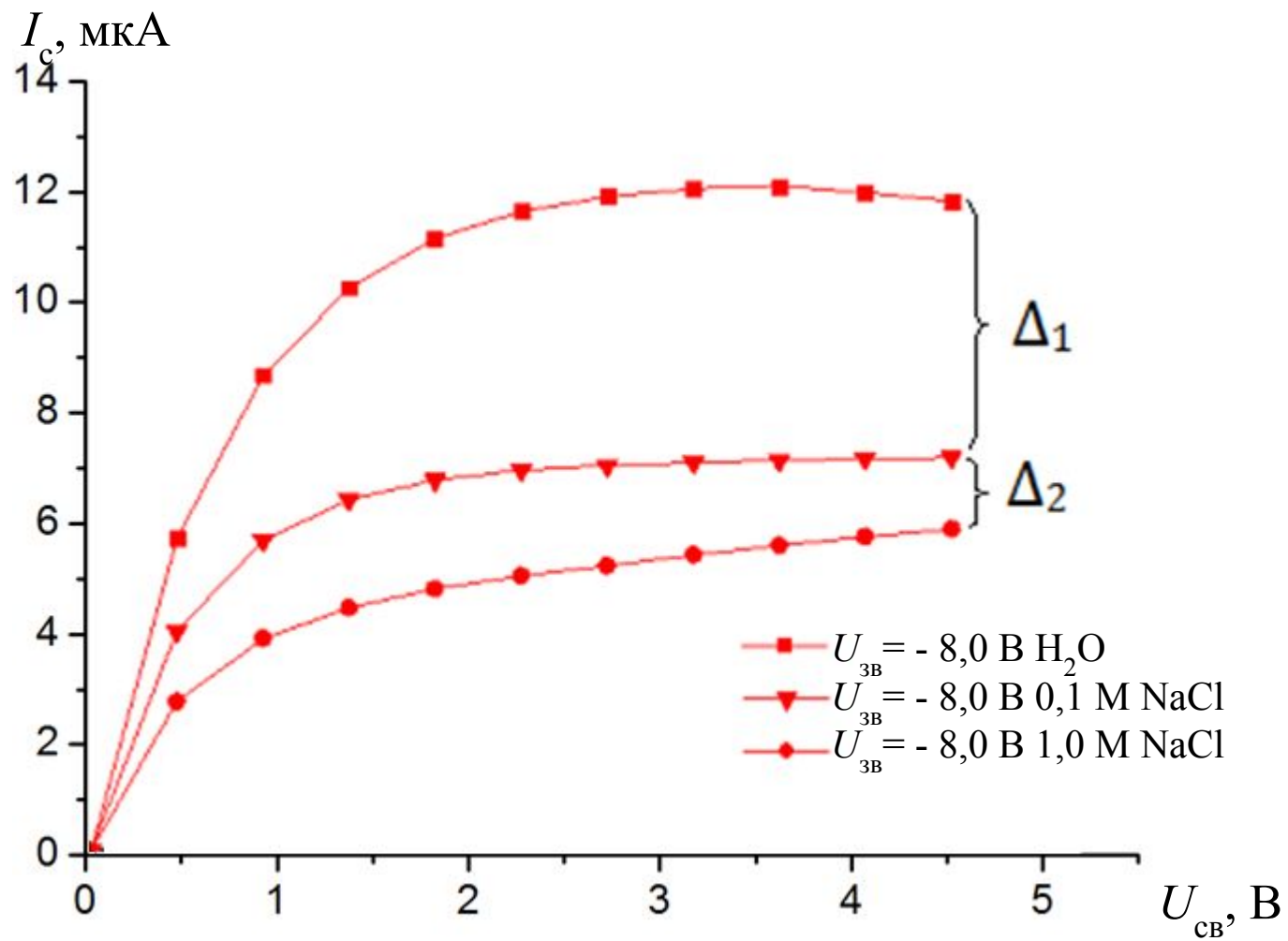

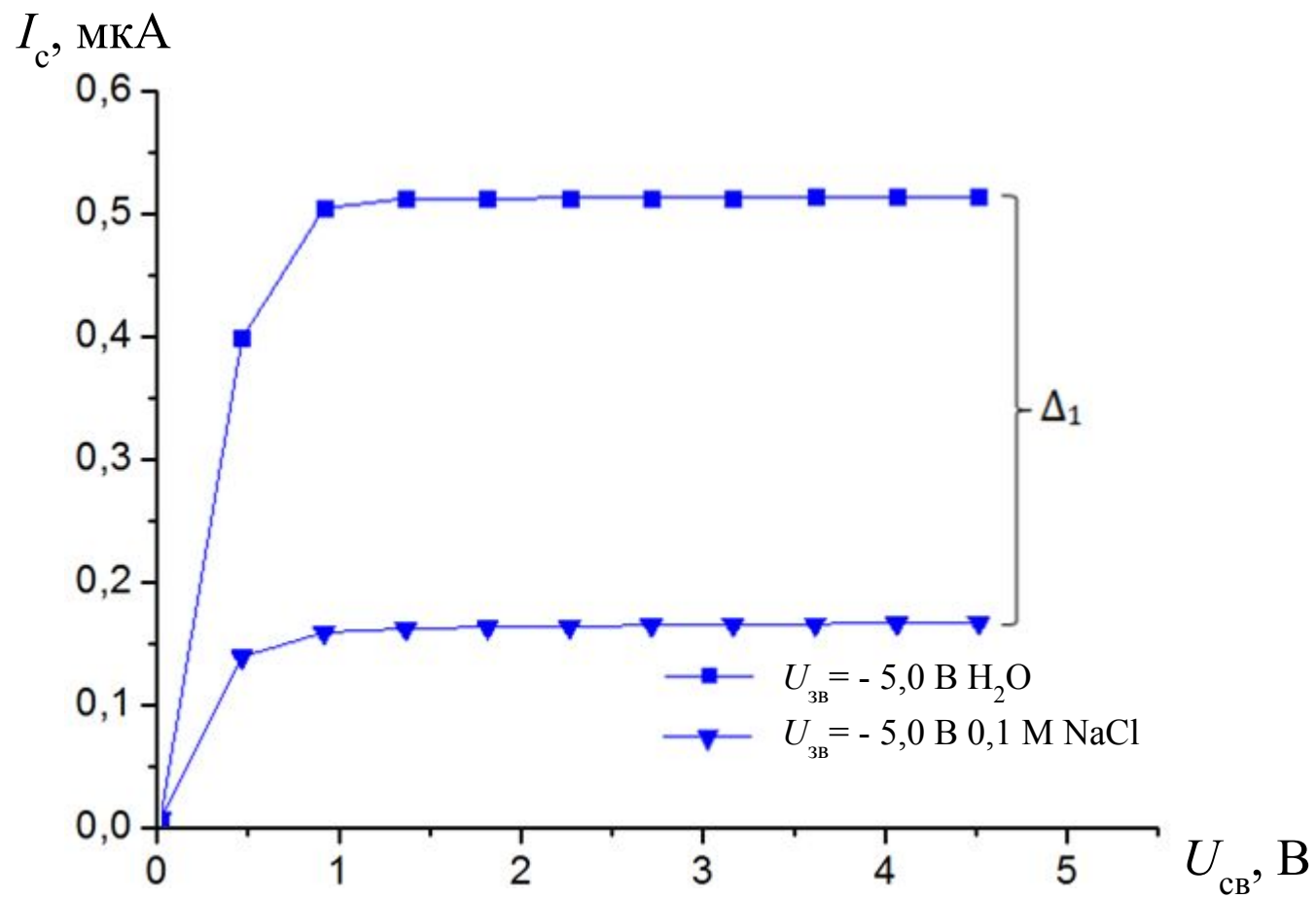

I_c , μA

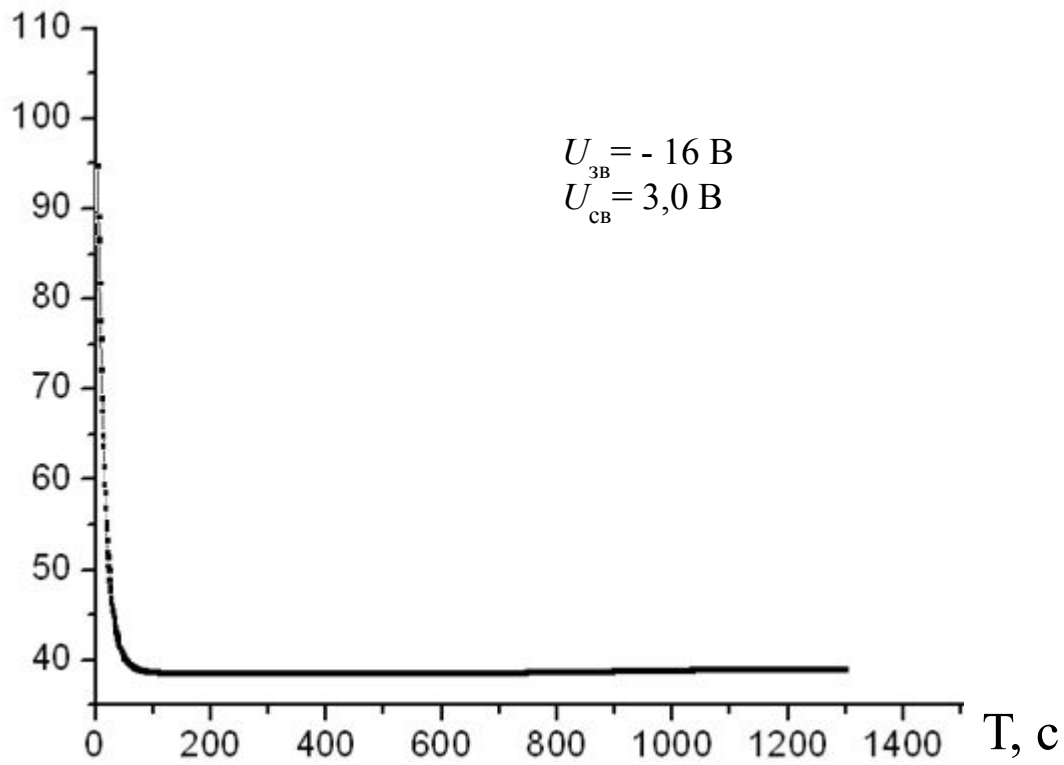

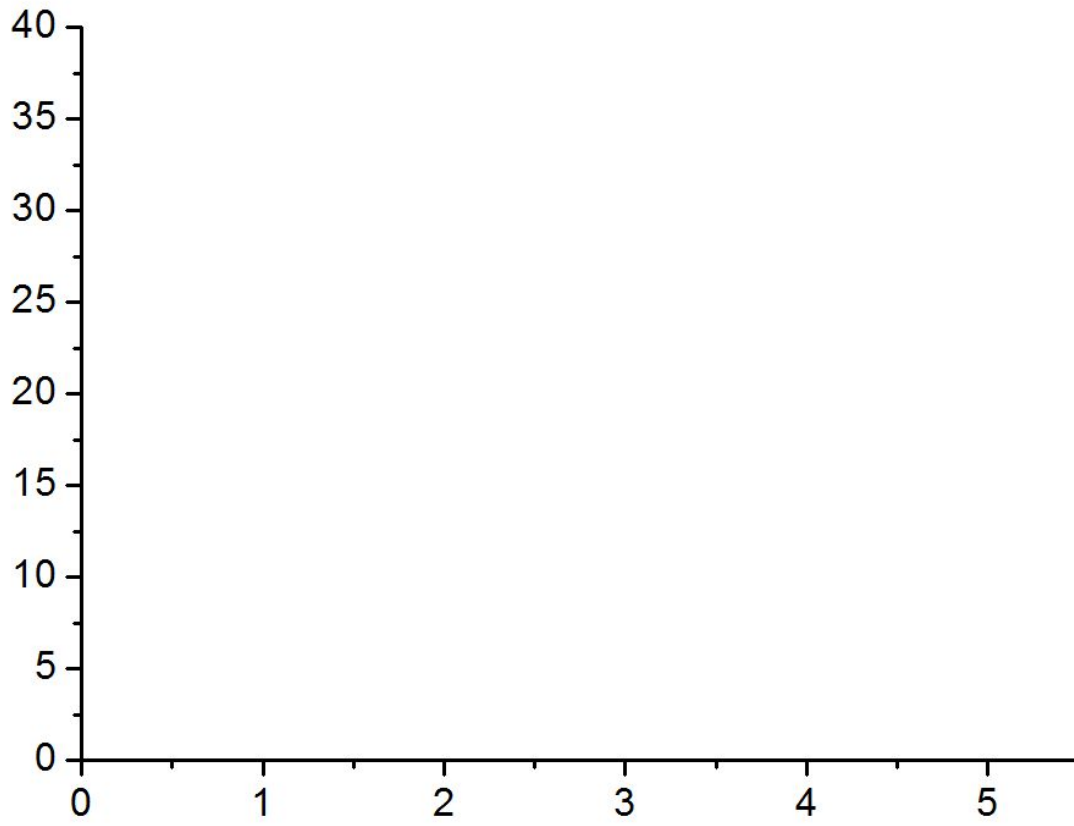

Товщина ліній
2
Шрифт 24

$I_c, \text{мкА}$

$U_{3B} = -16\text{В}$

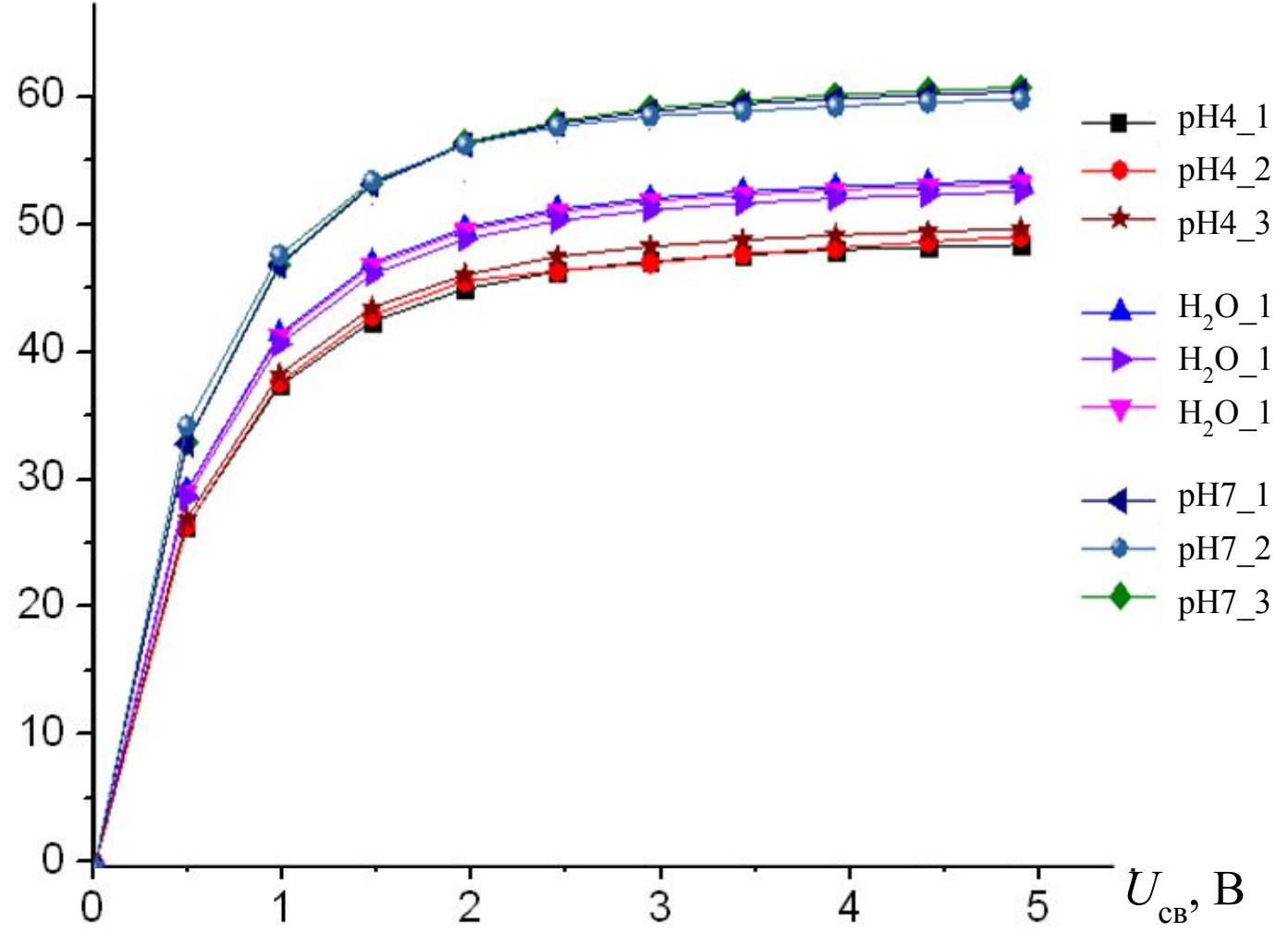

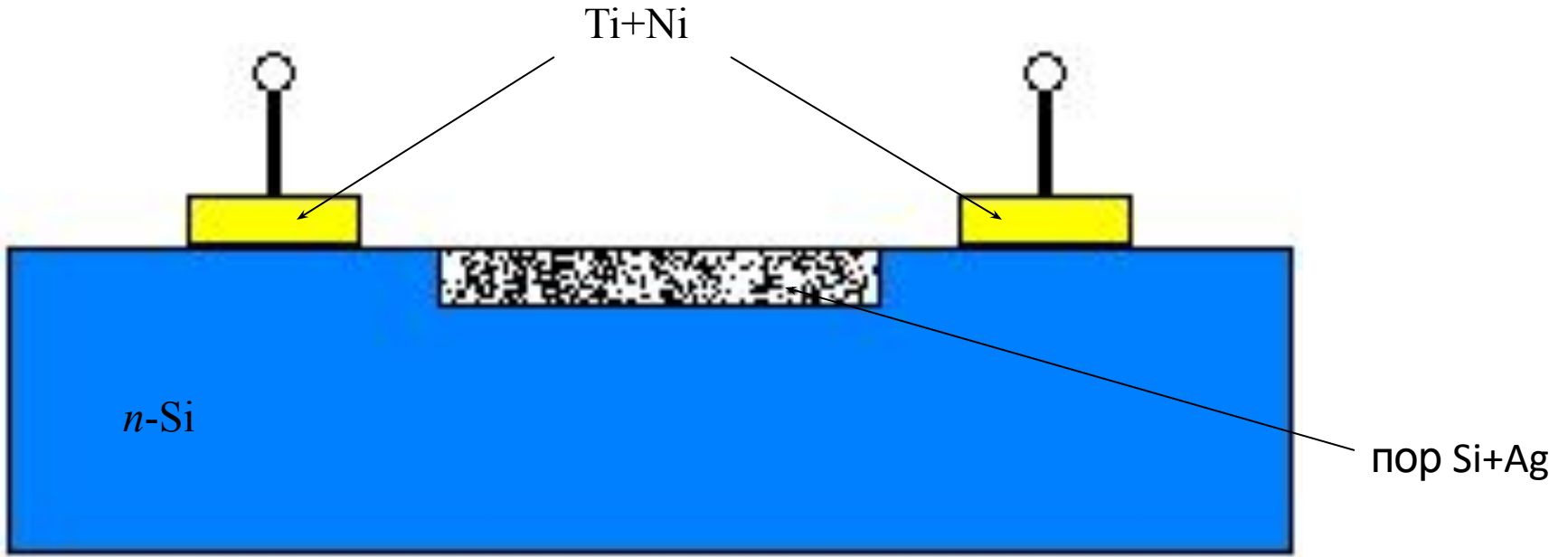

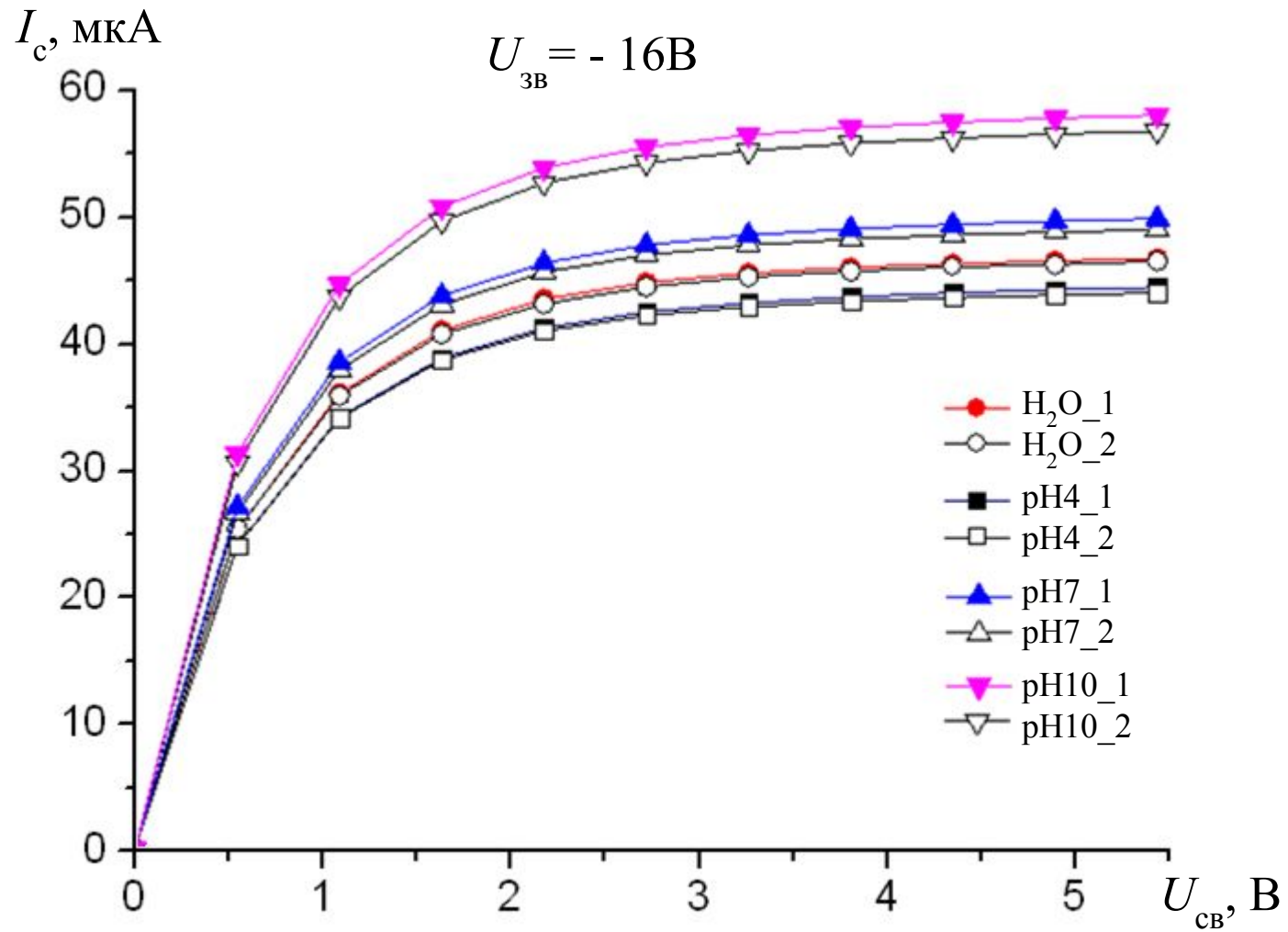

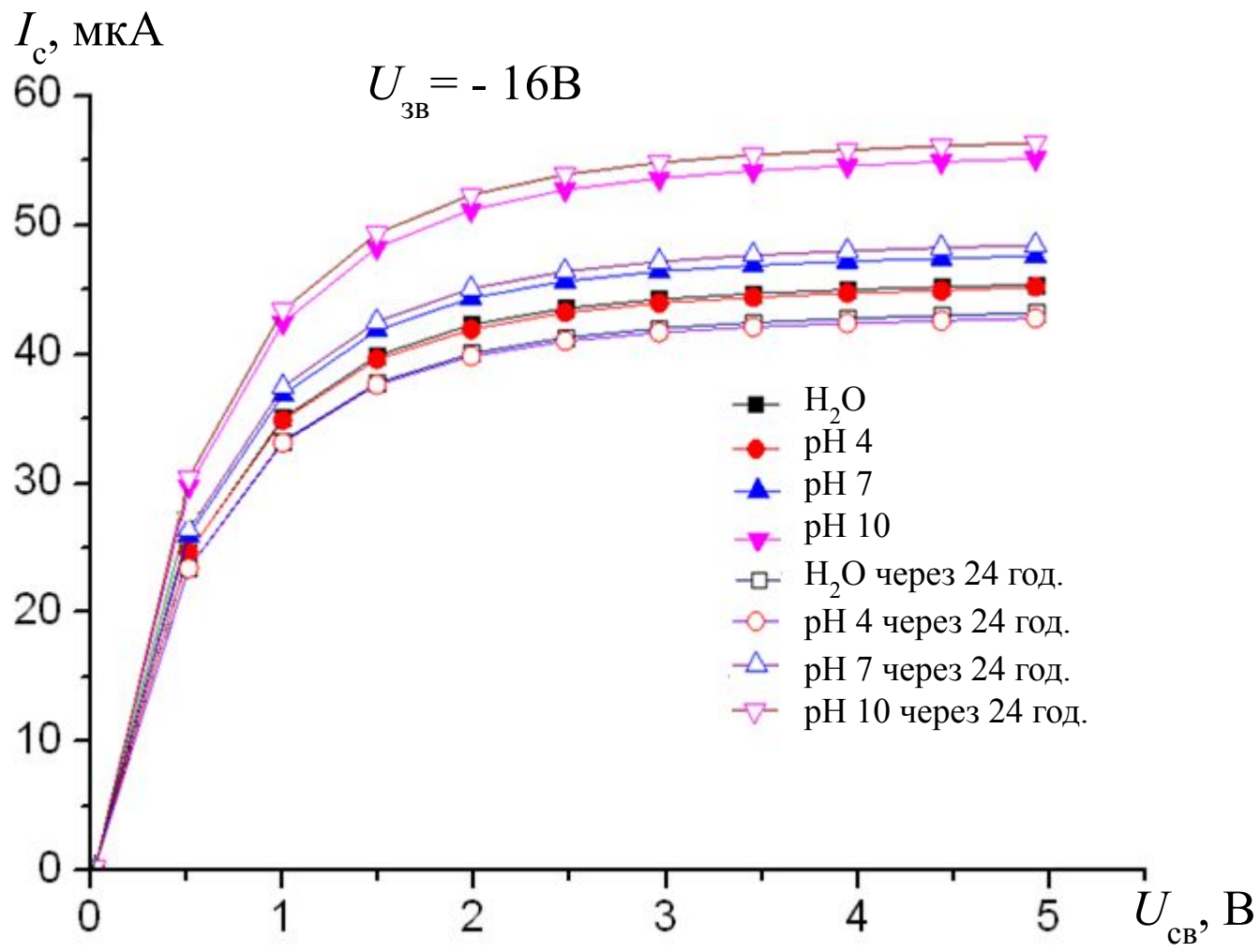

$I_c, \mu A$

$U_{3B} = -16 V, C=1 \text{ г/л}, \text{pH } 8$

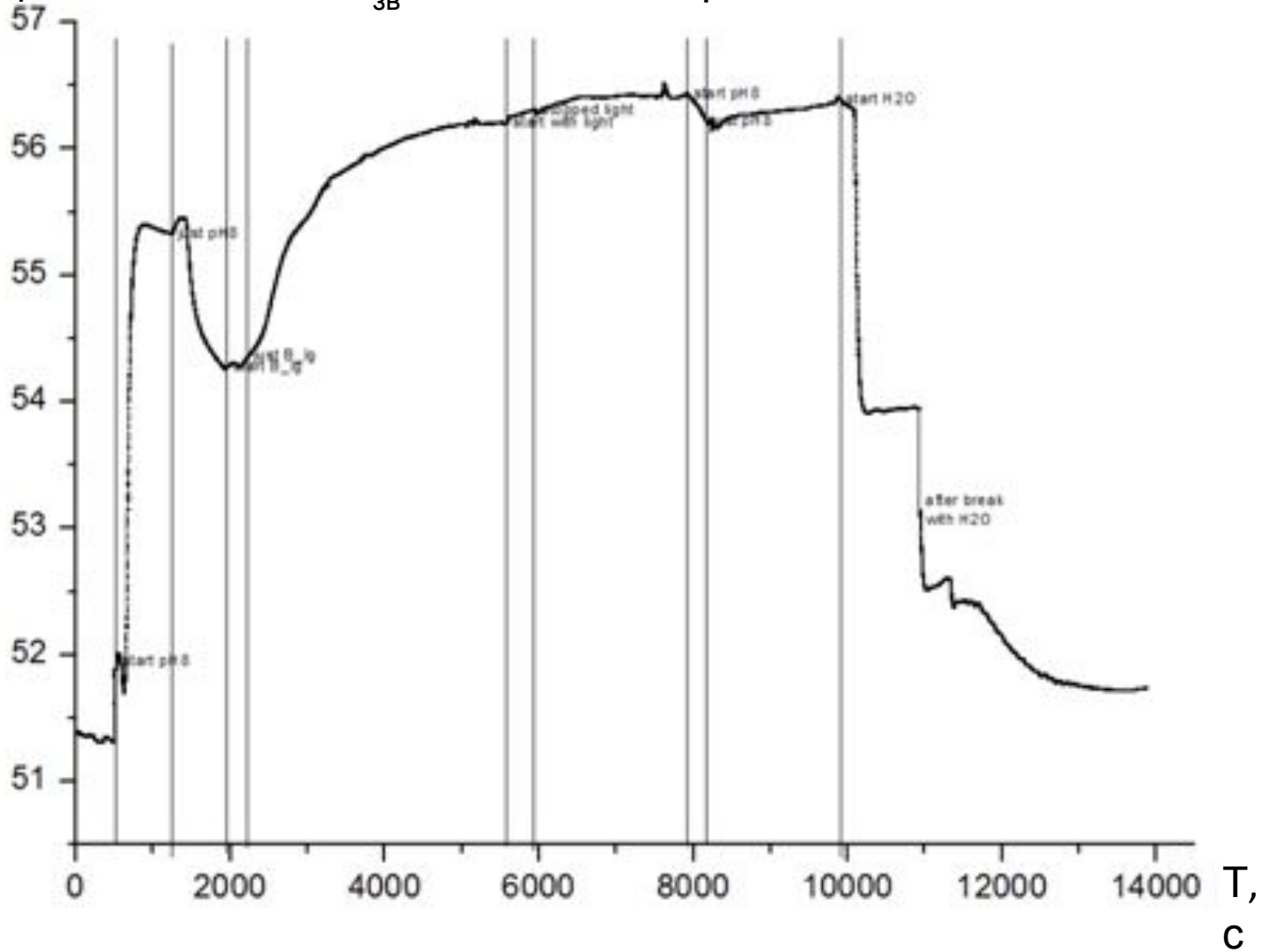

I_c , мкА

$U_{3B} = -16$ В, $C=1$ г/л, рН 6

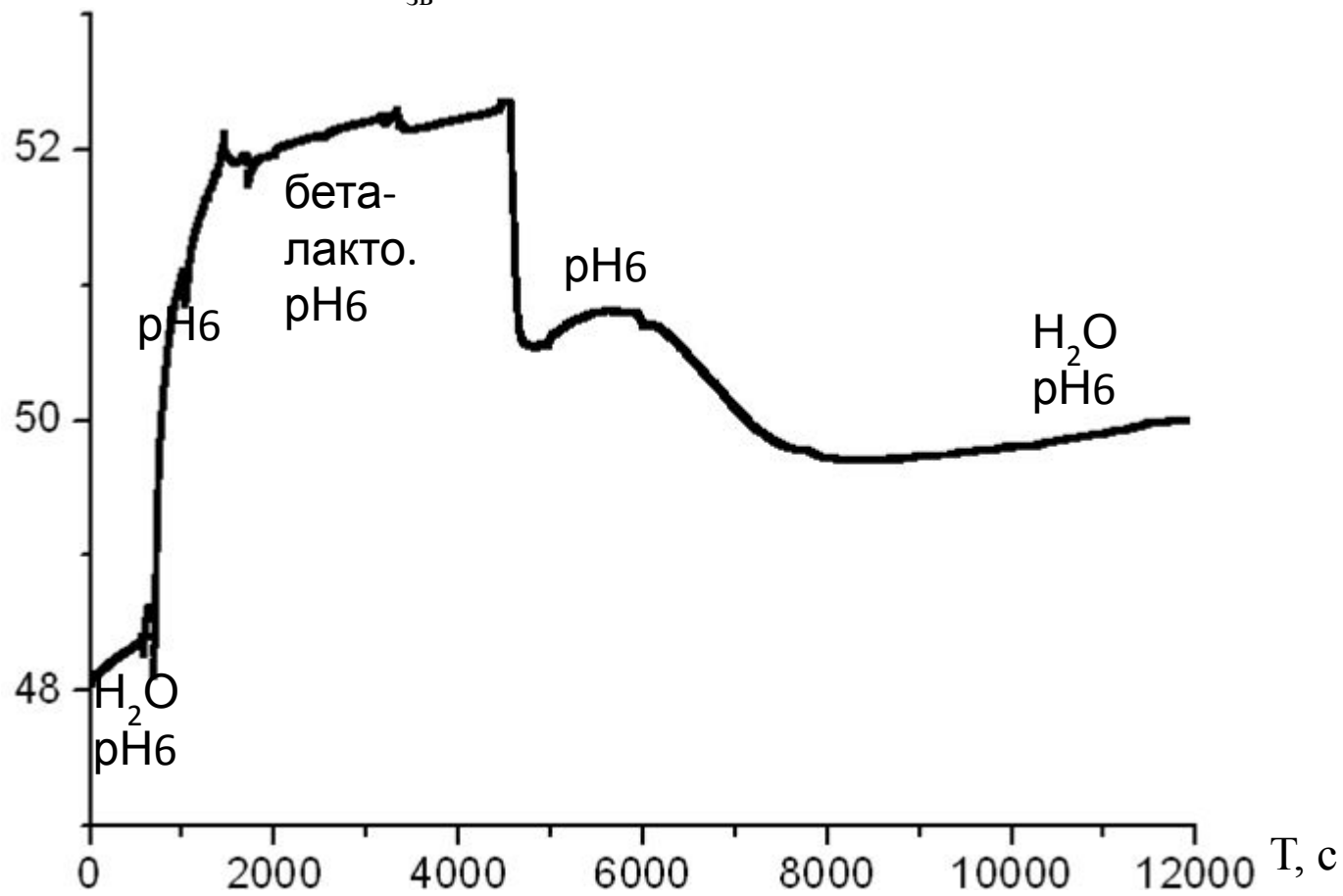

$I_c, \mu A$

$U_{3B} = -16 V, C=1 \text{ г/л}, \text{pH } 4$

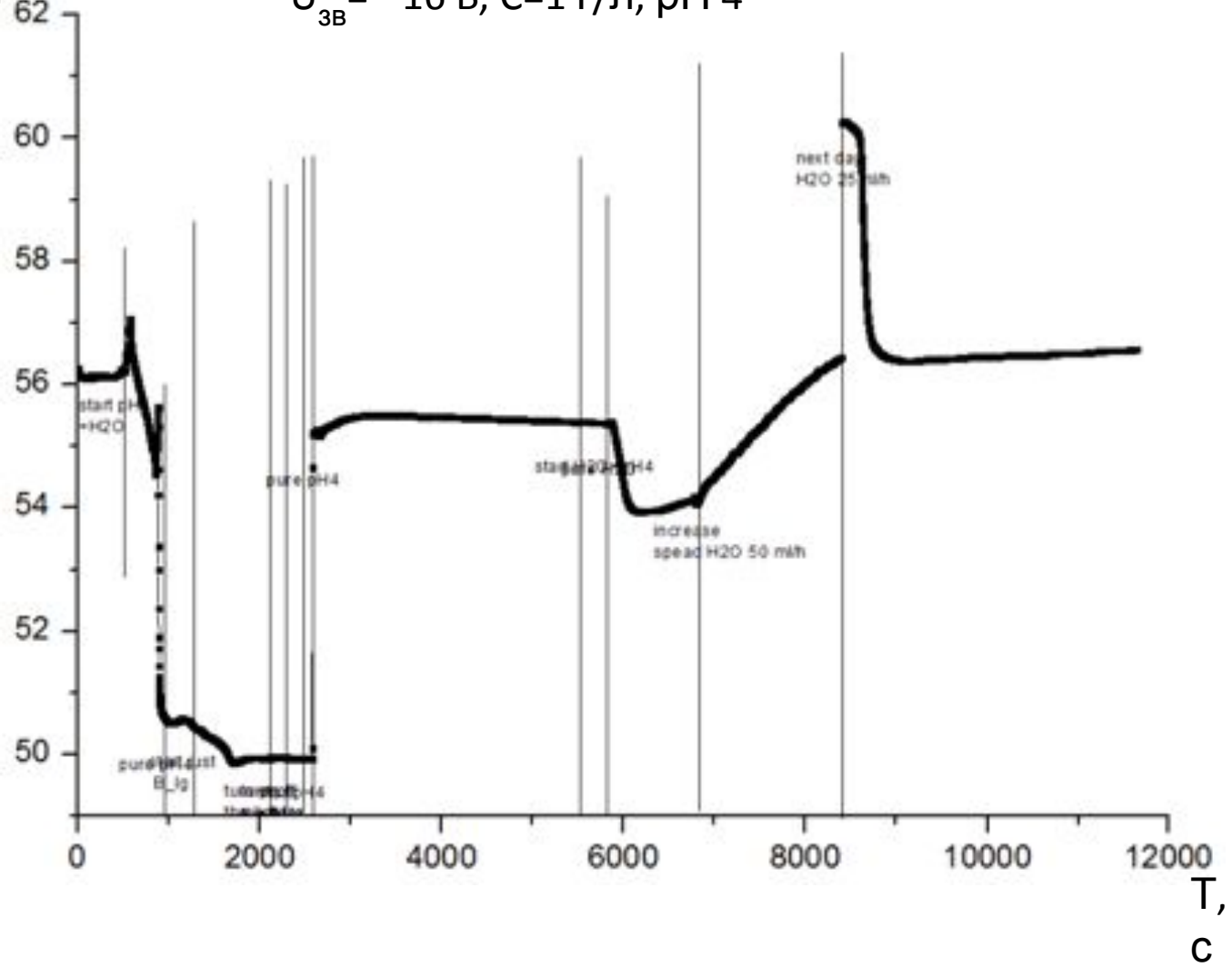

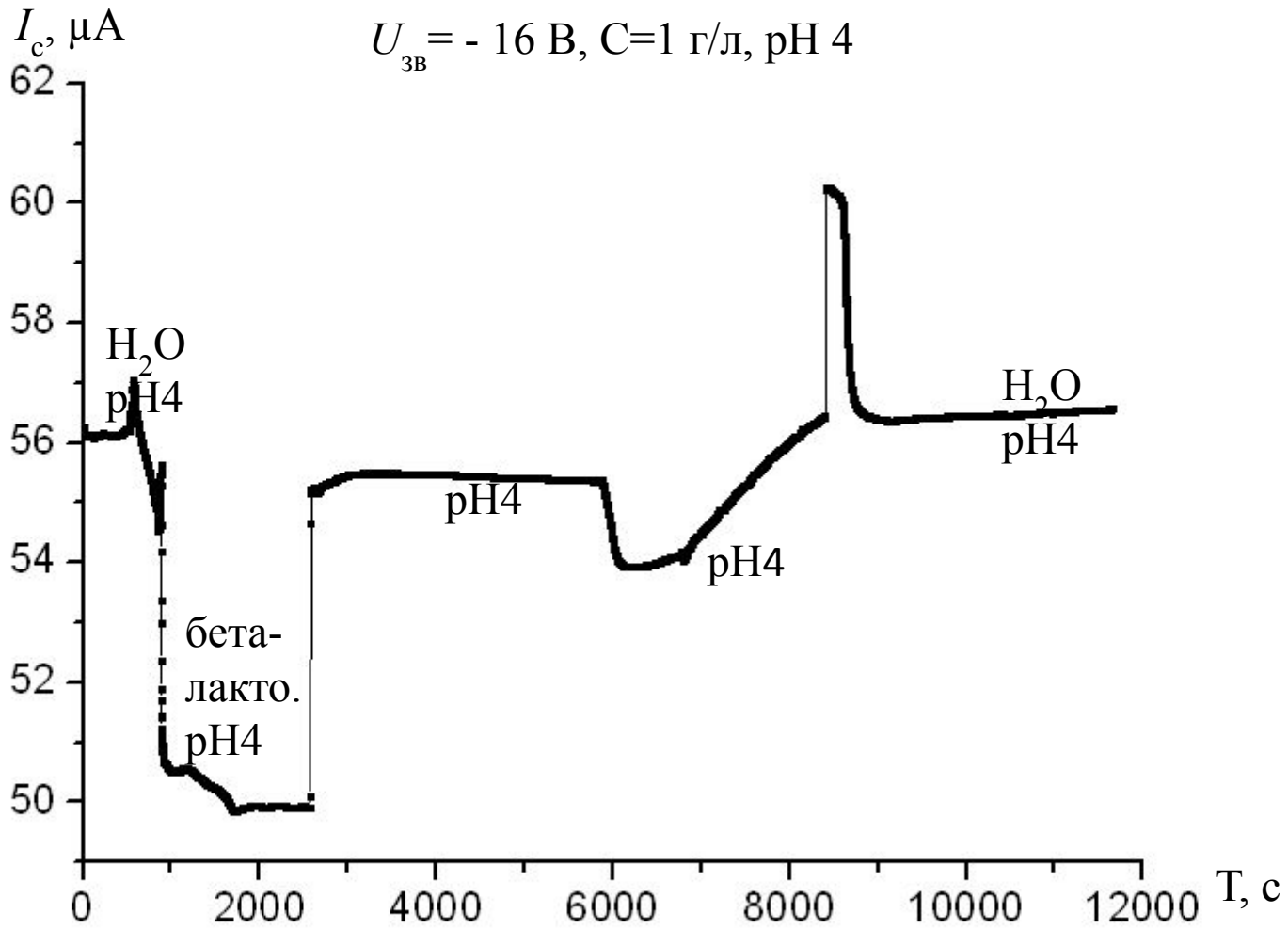

$I_c, \mu A$

$U_{3B} = -16 V, C=1 \text{ г/л}, \text{pH } 8$

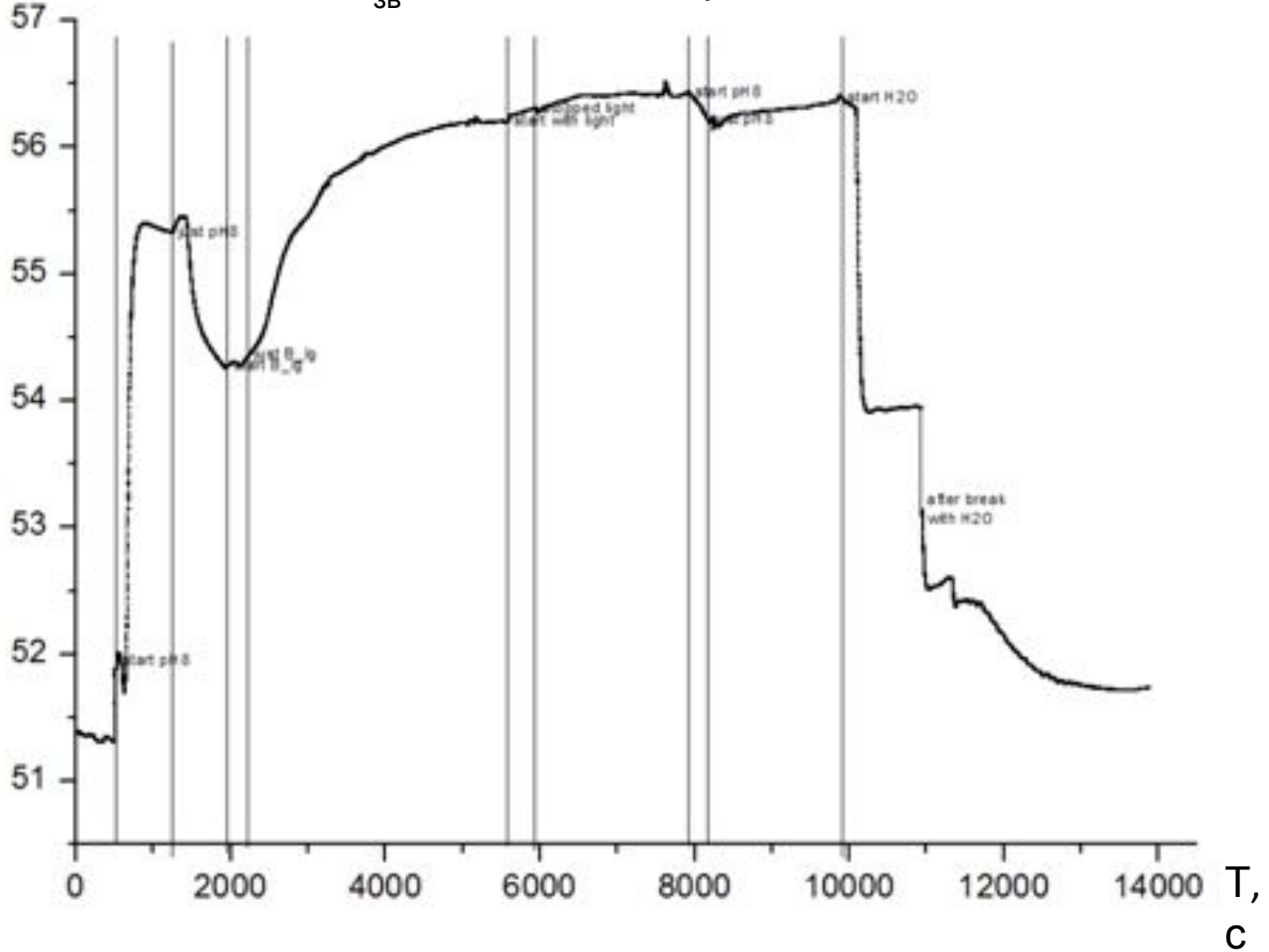

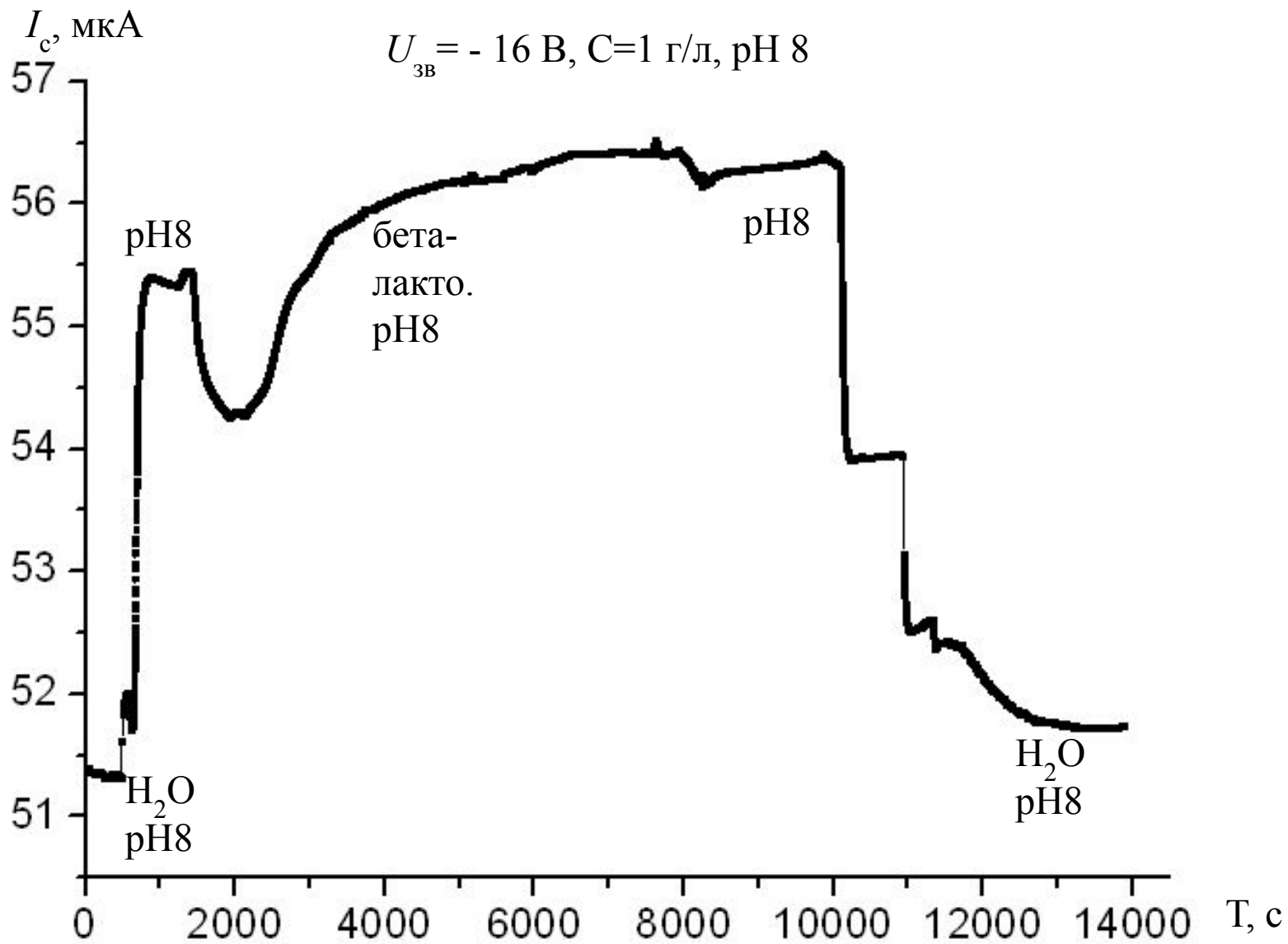

$U_{3B} = -16 \text{ V}, C=10 \text{ г/л}, \text{pH } 6$

$I_c, \mu\text{A}$

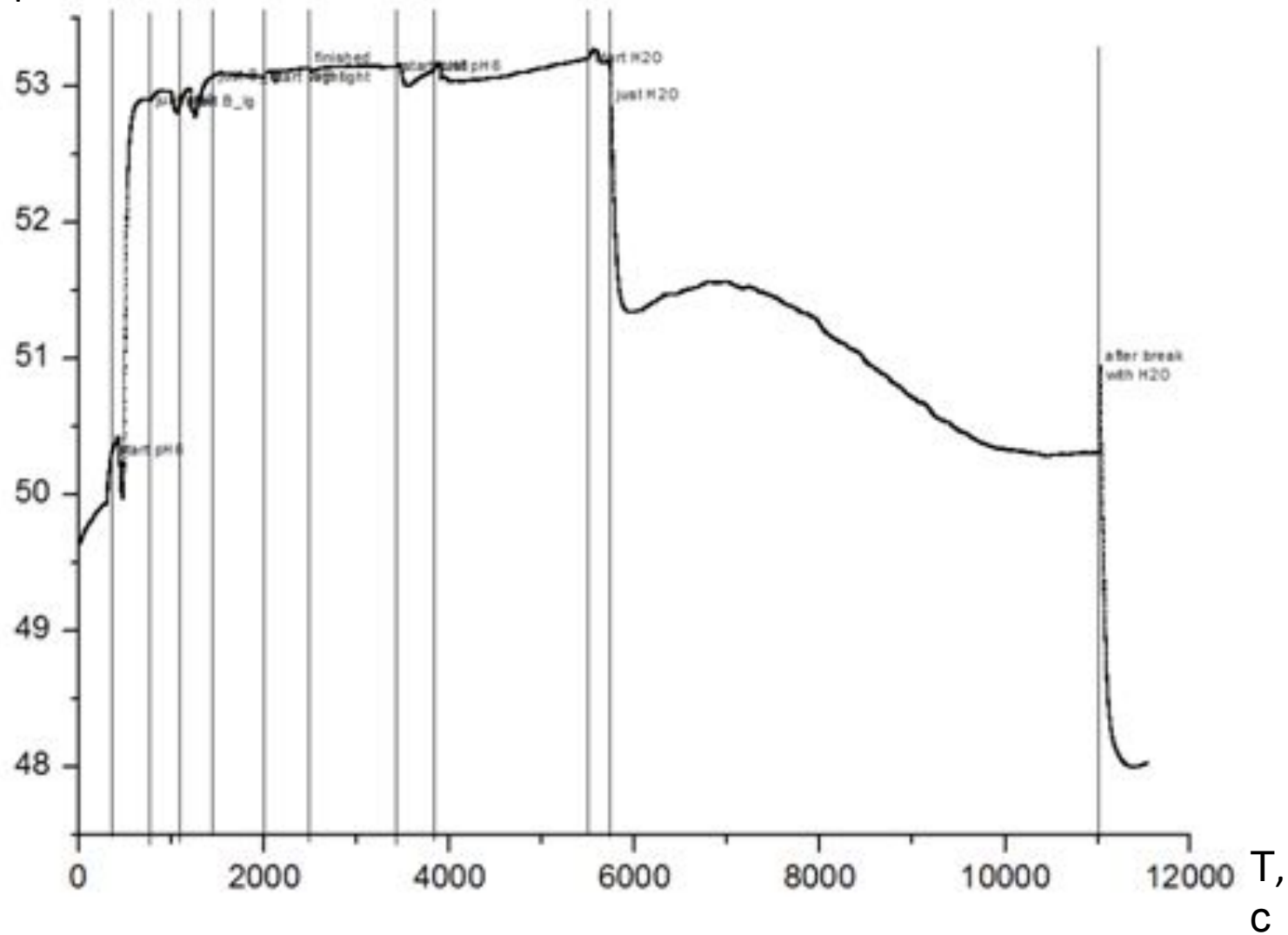

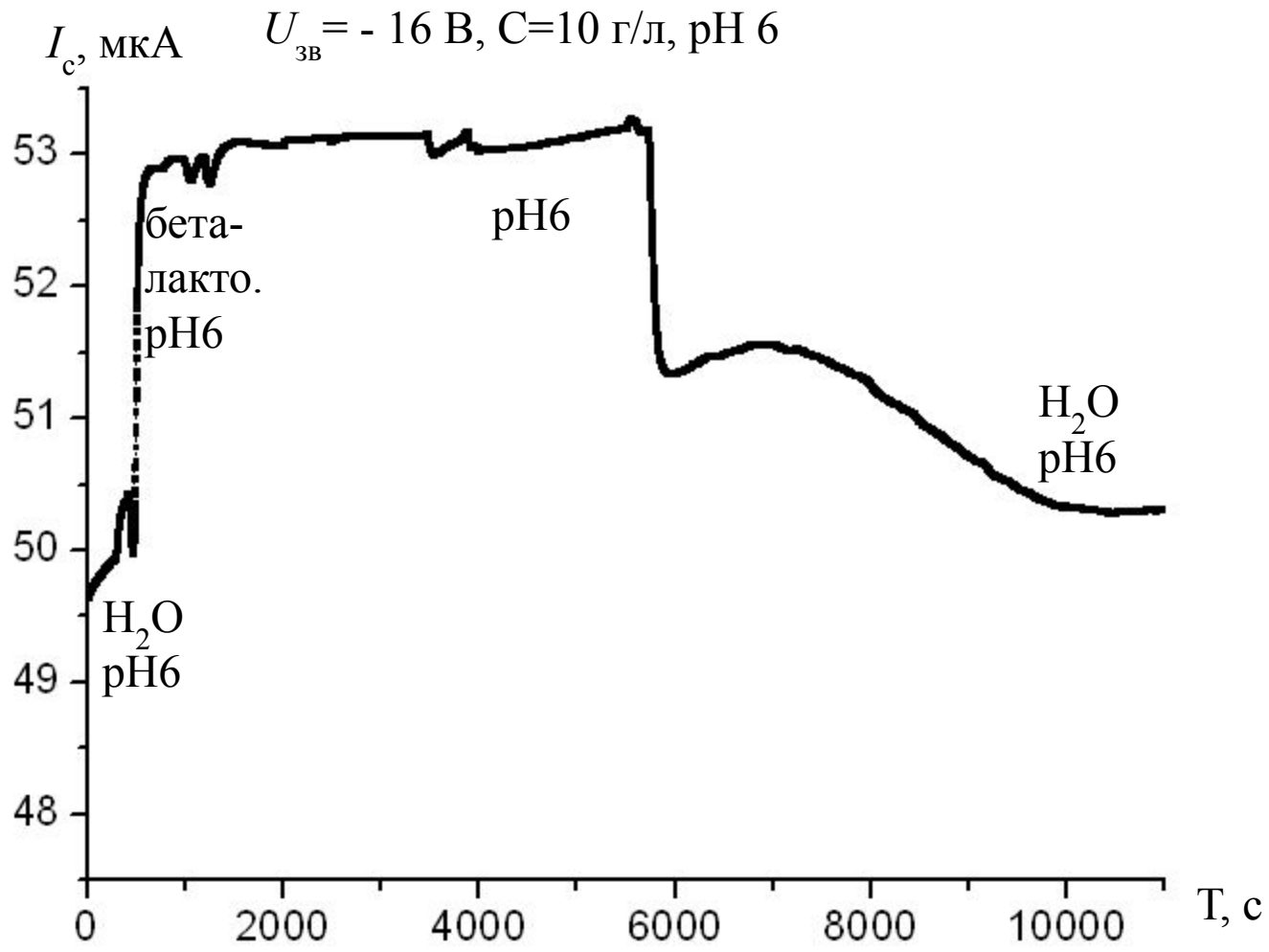

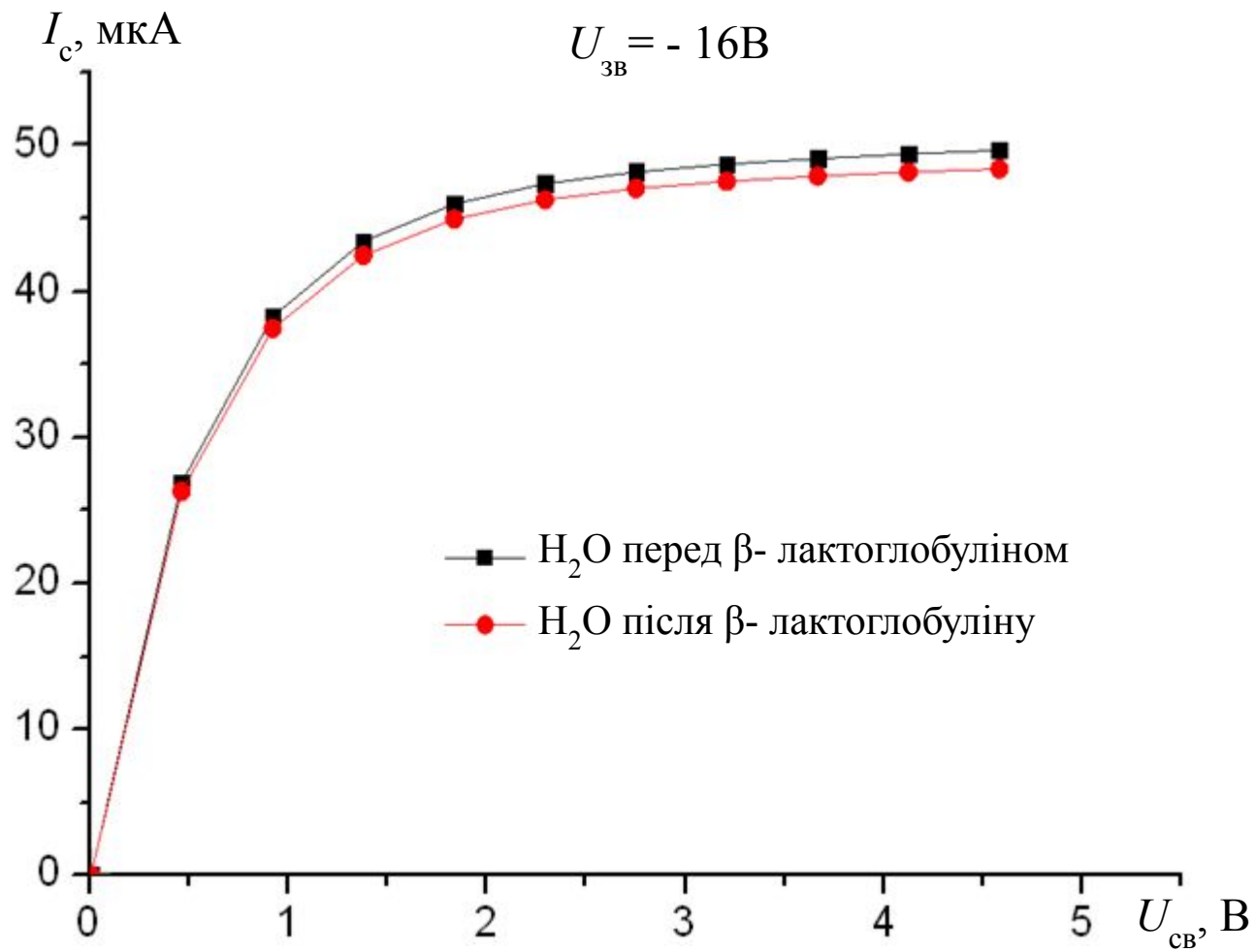

I_c , мкА

$U_{3B} = -16$ В, $C=1$ г/л

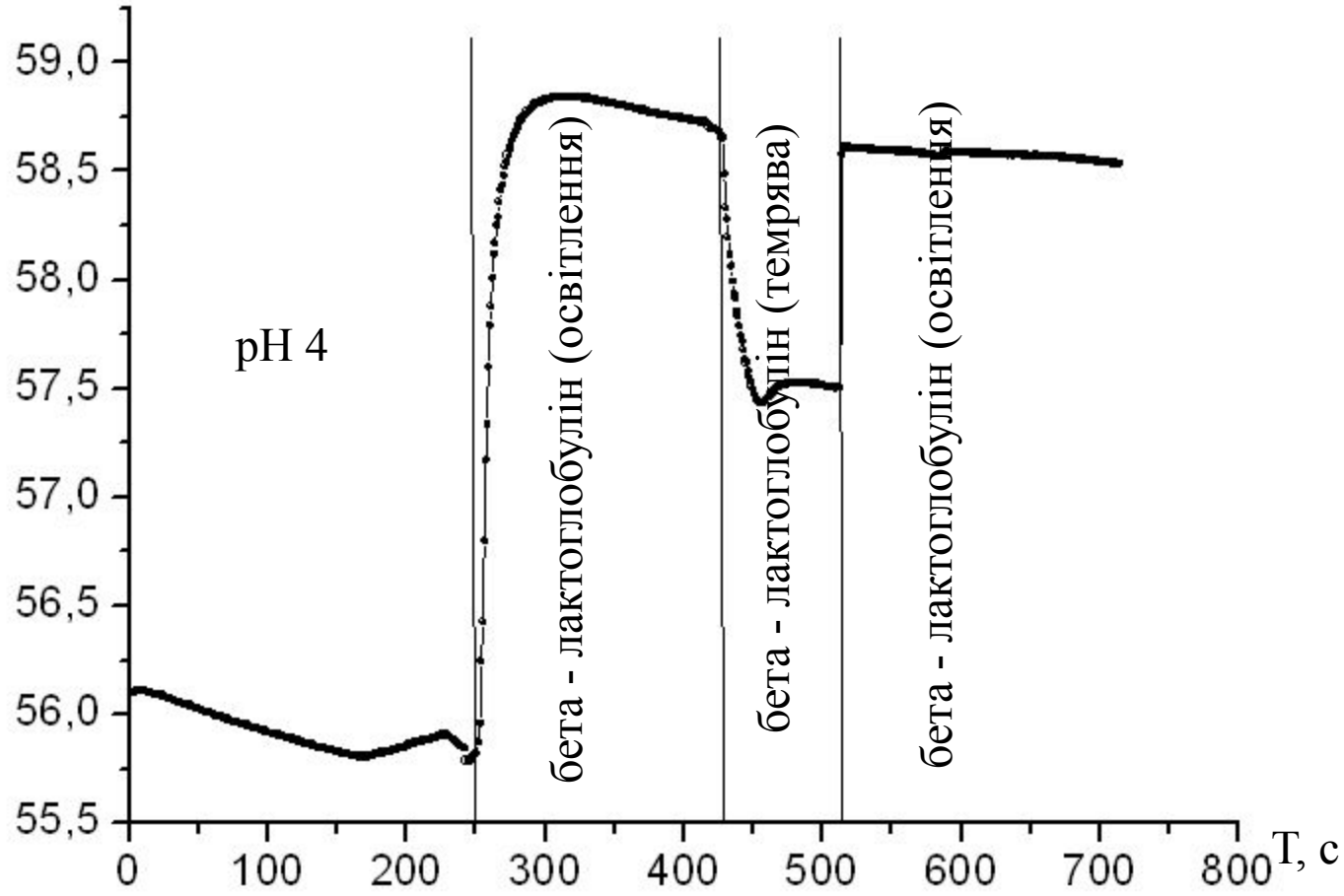

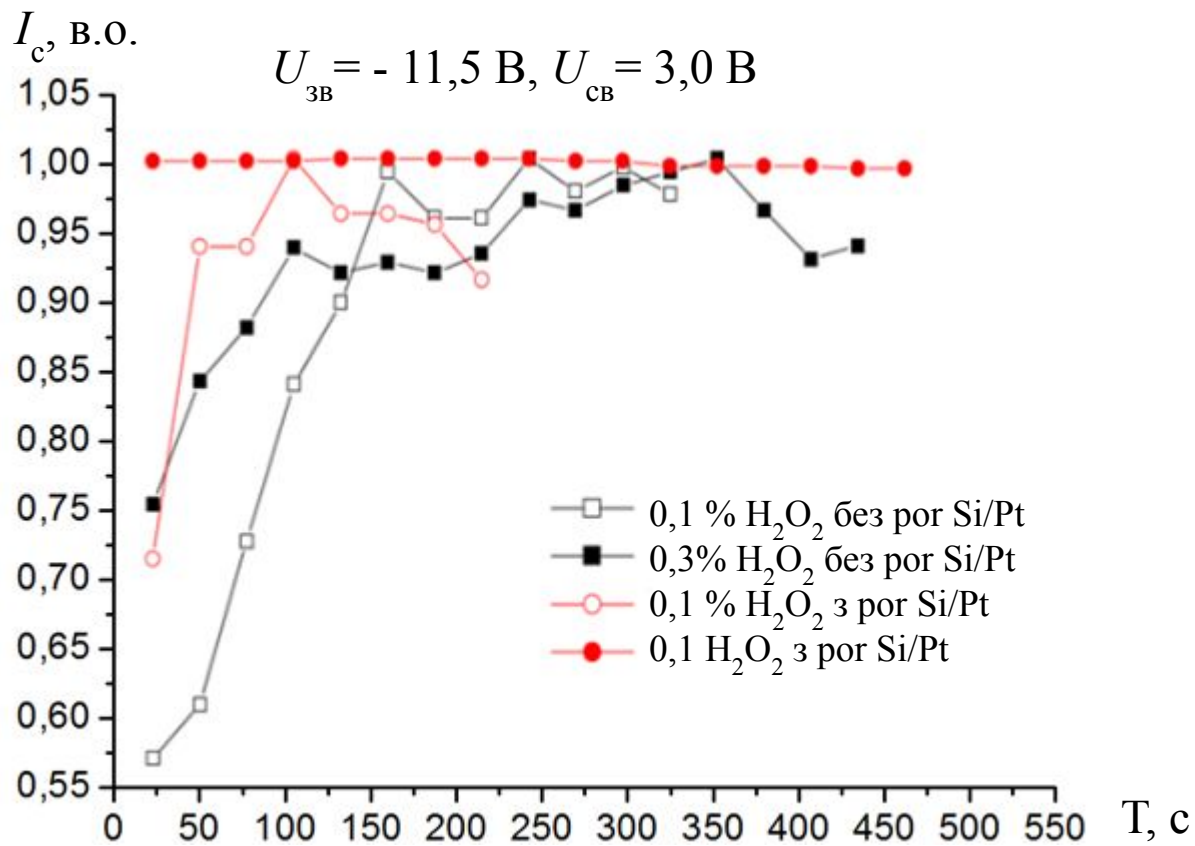

$I_{\text{фг}}$, мкА

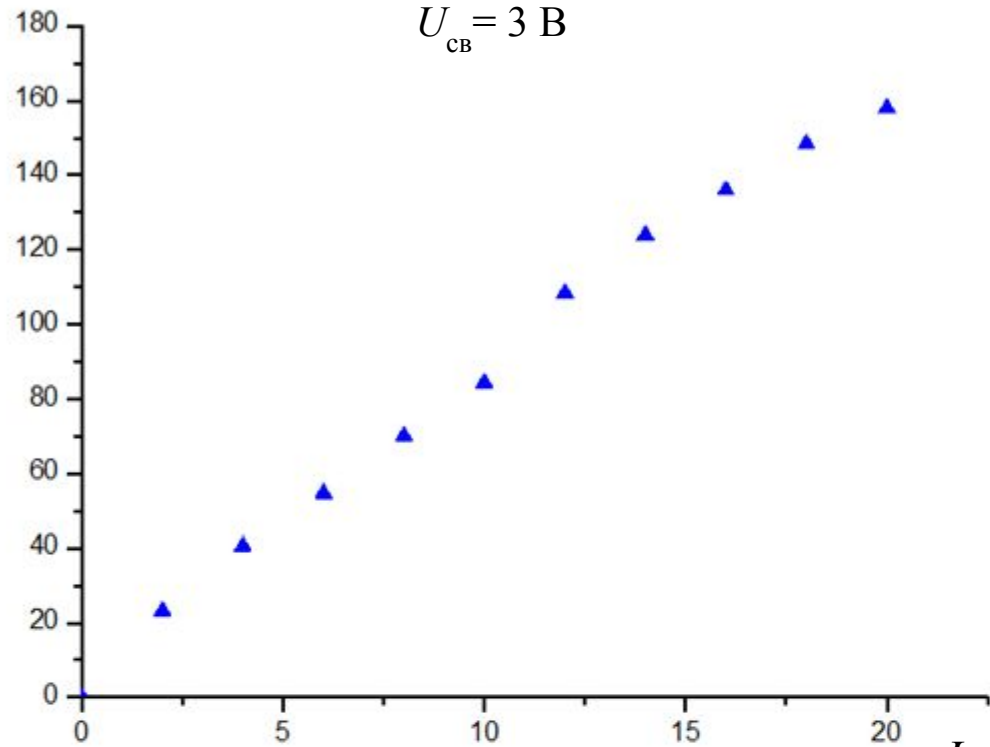

$I_{\text{світлодіода}}$, мА

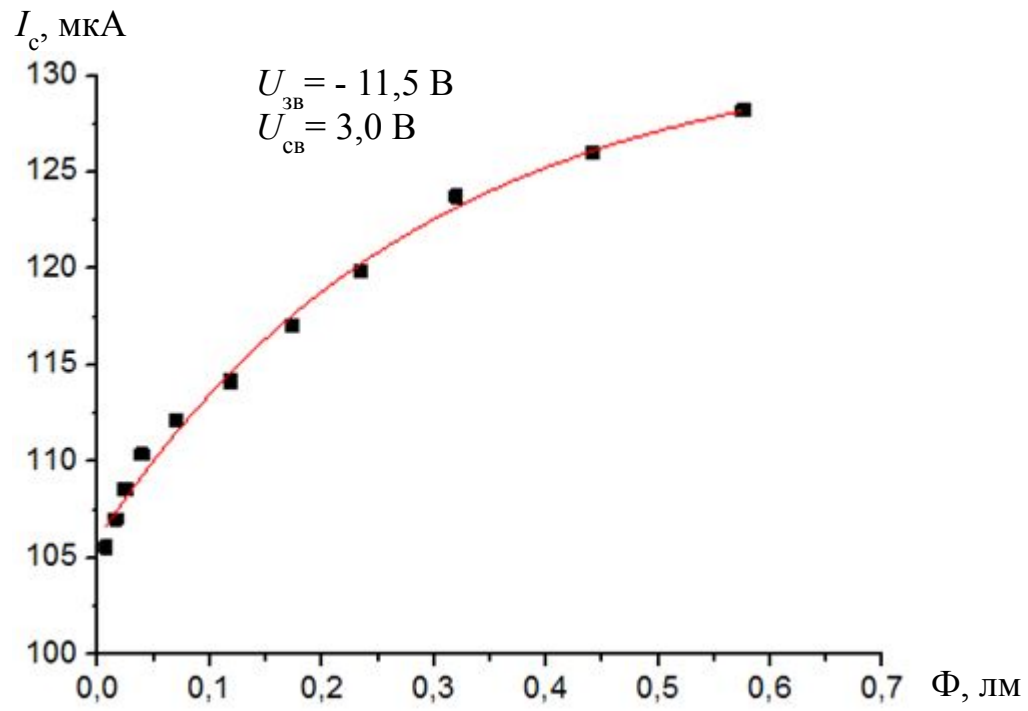

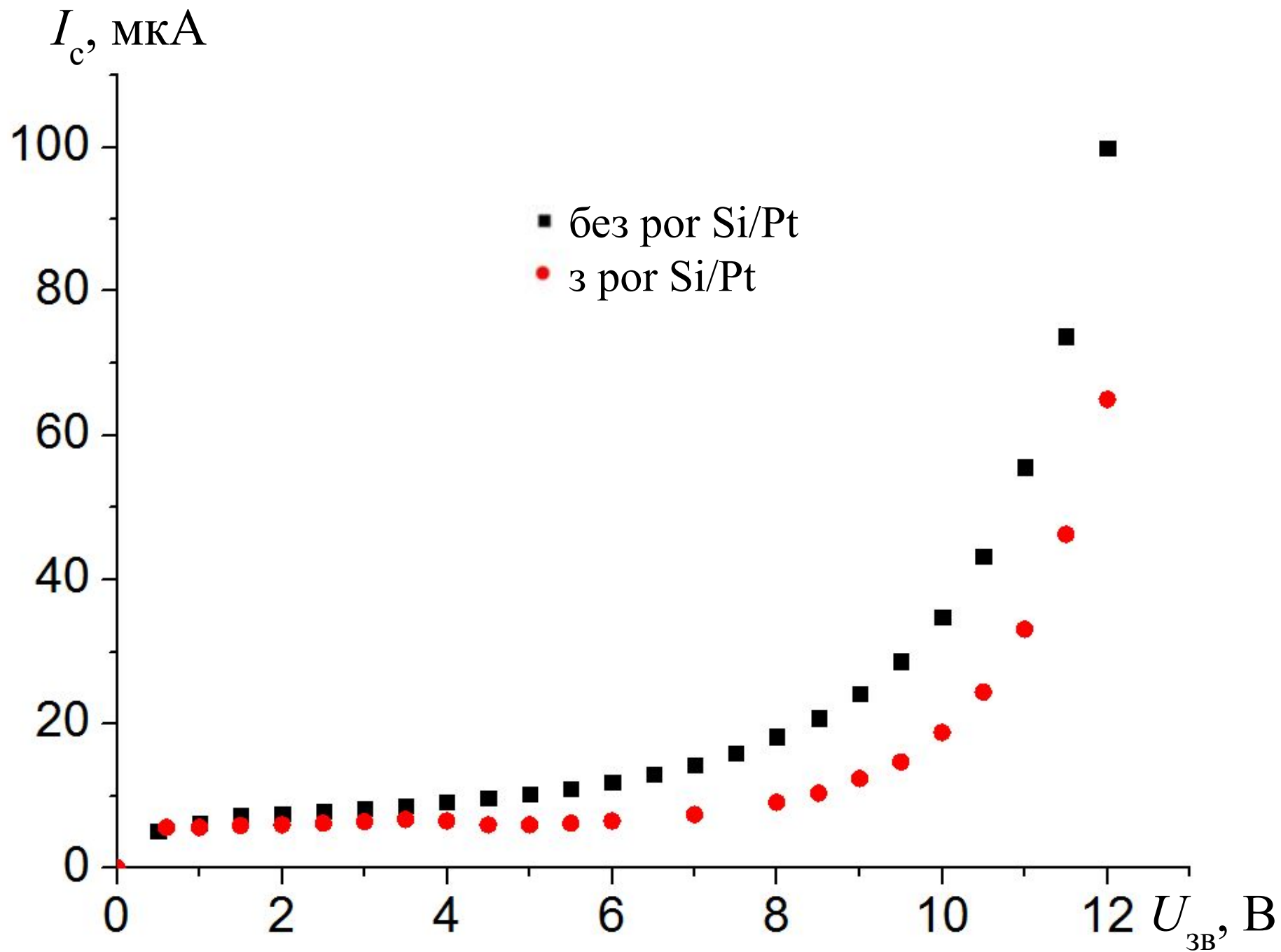

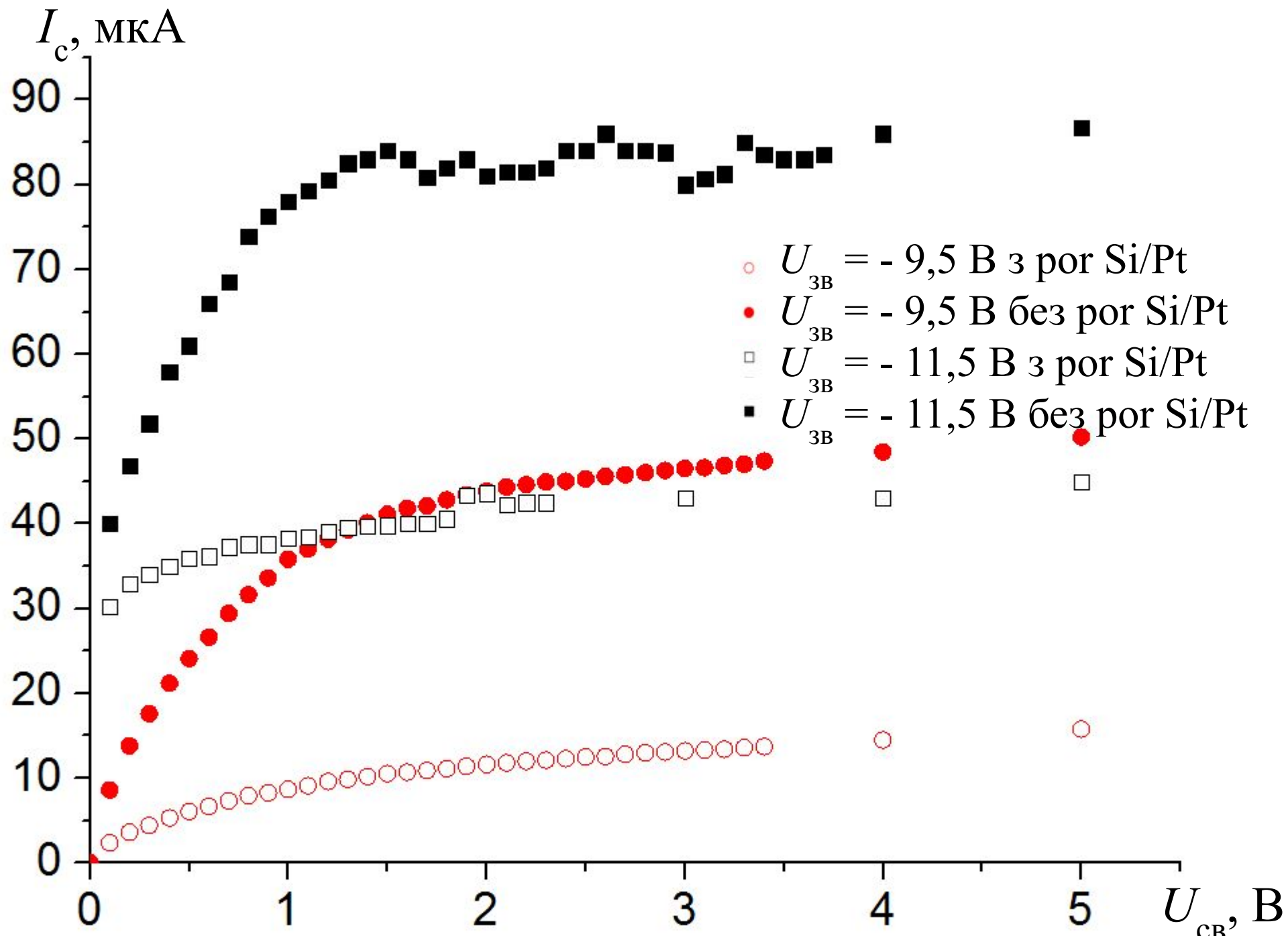

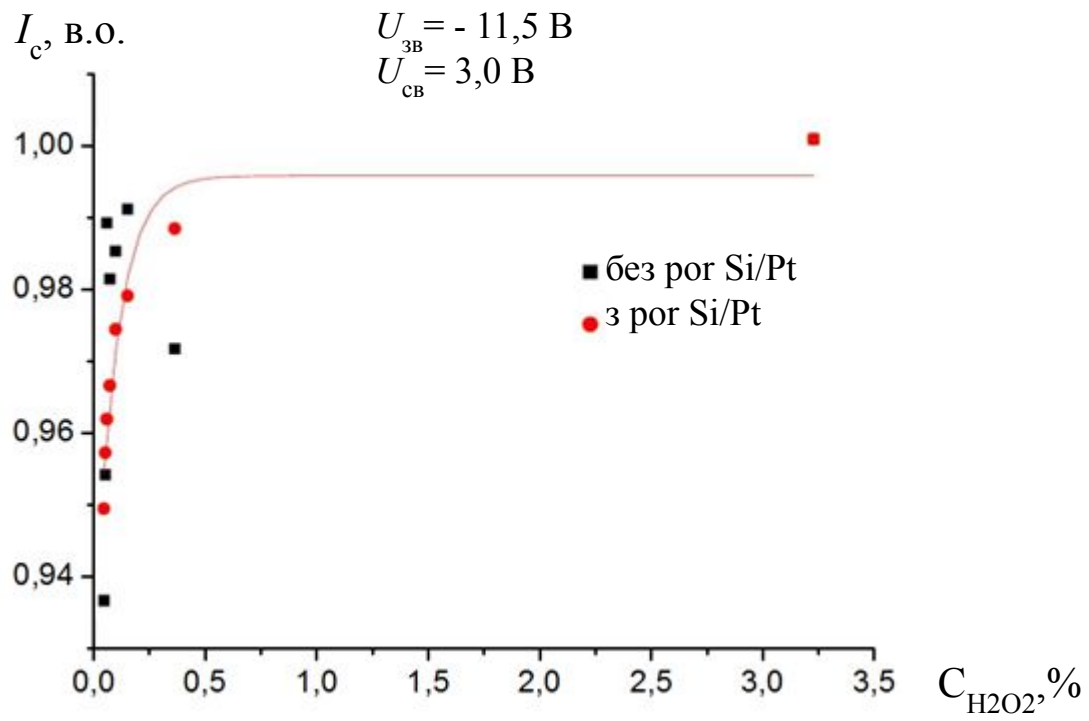

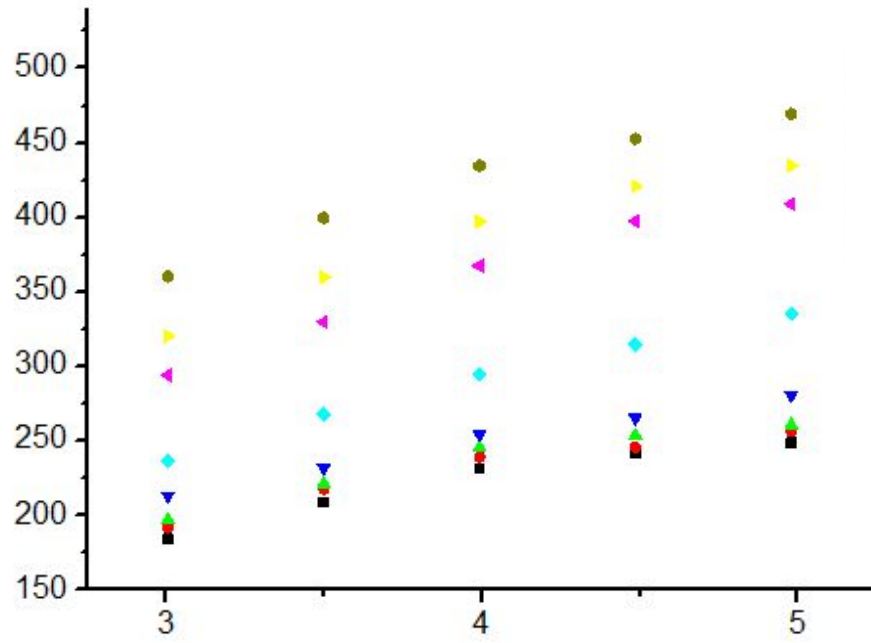

I_c , мкА

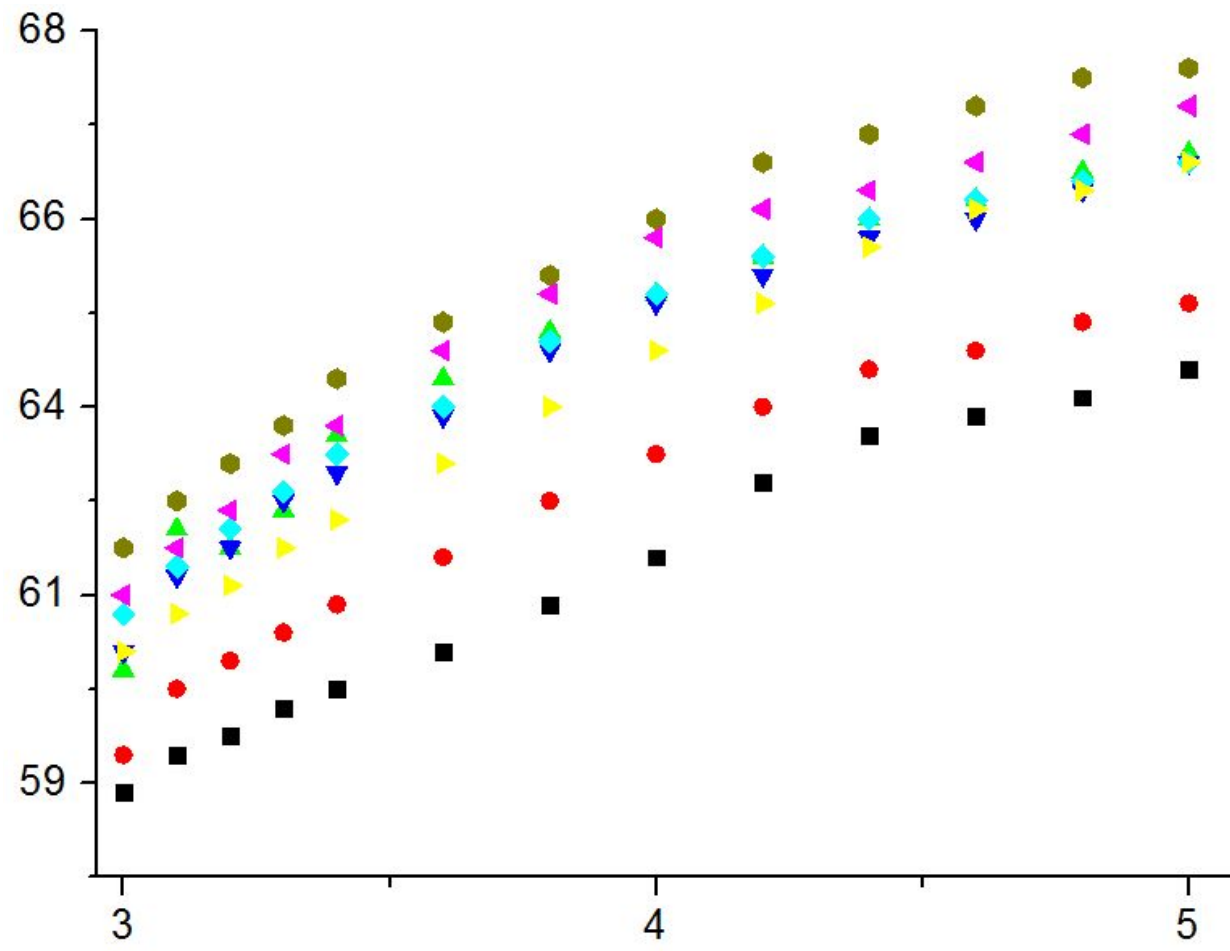

без пор Si/Pt
 $U_{3B} = -11,5$ В

- 0 % H_2O_2
- 0,00625 % H_2O_2
- ▲ 0,0125 % H_2O_2
- ▼ 0,0250 % H_2O_2
- ◆ 0,05 % H_2O_2
- ◀ 0,1 % H_2O_2
- ▶ 0,3 % H_2O_2
- 3 % H_2O_2

U_{CB} , В

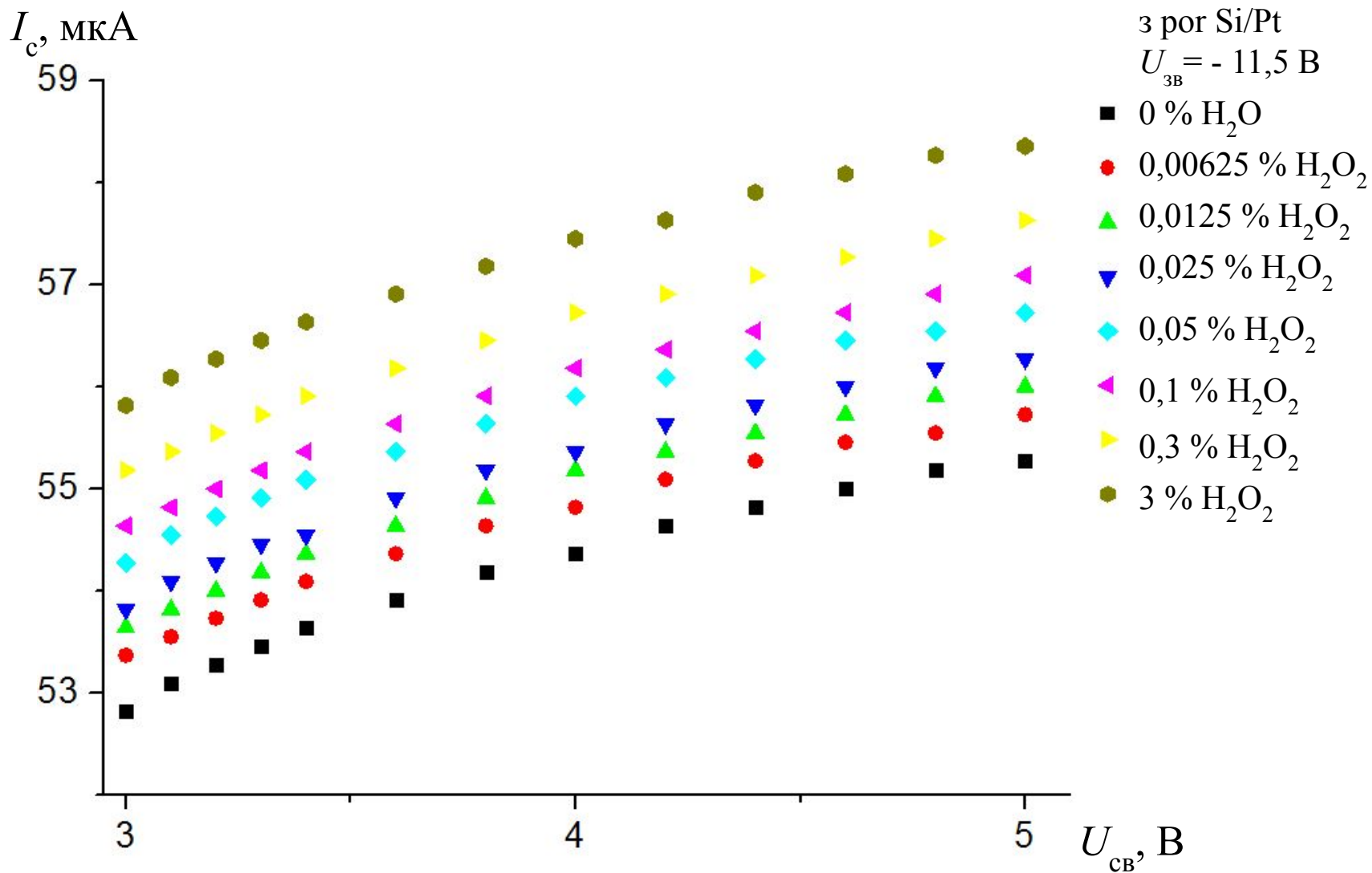

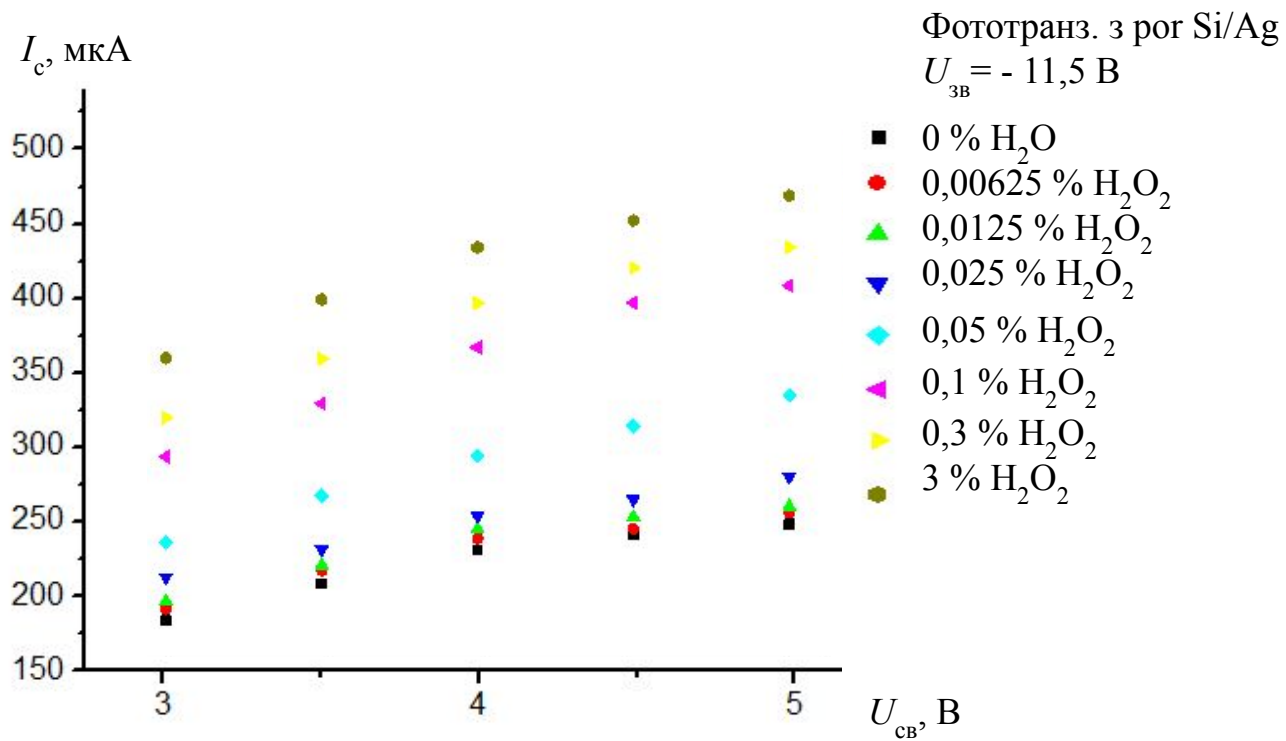

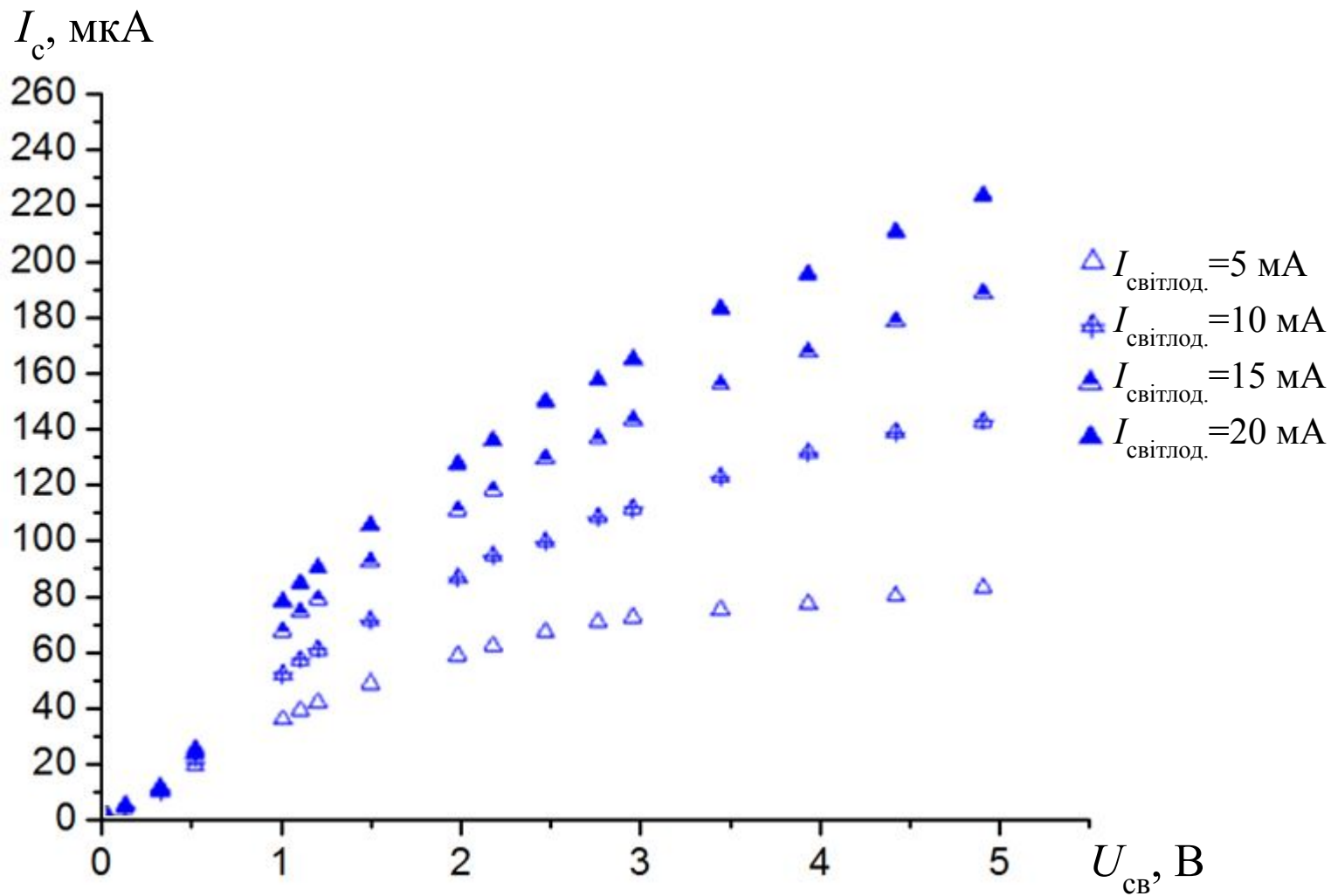

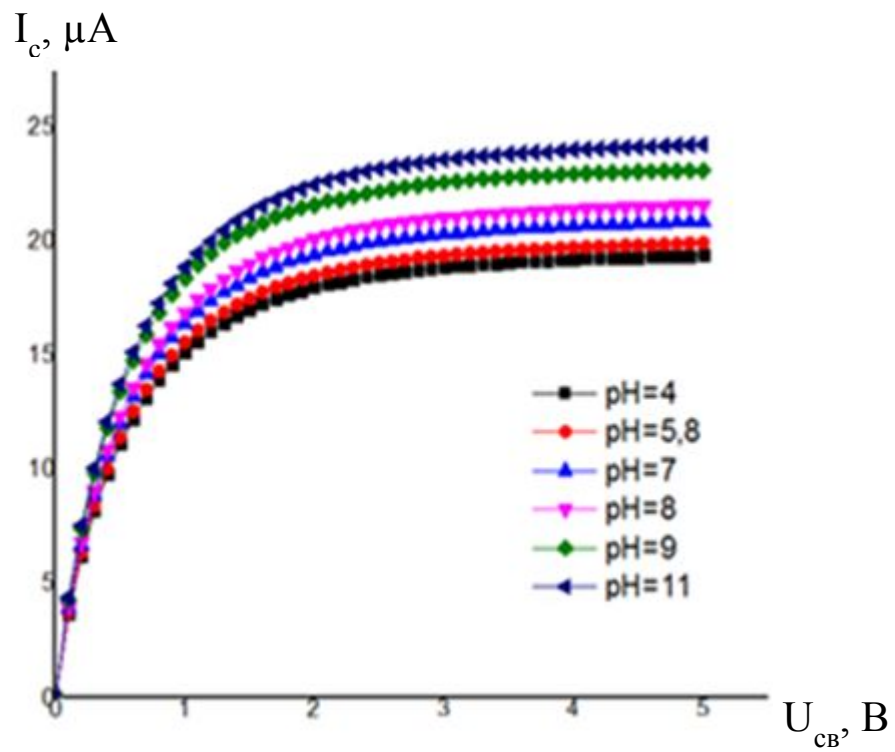

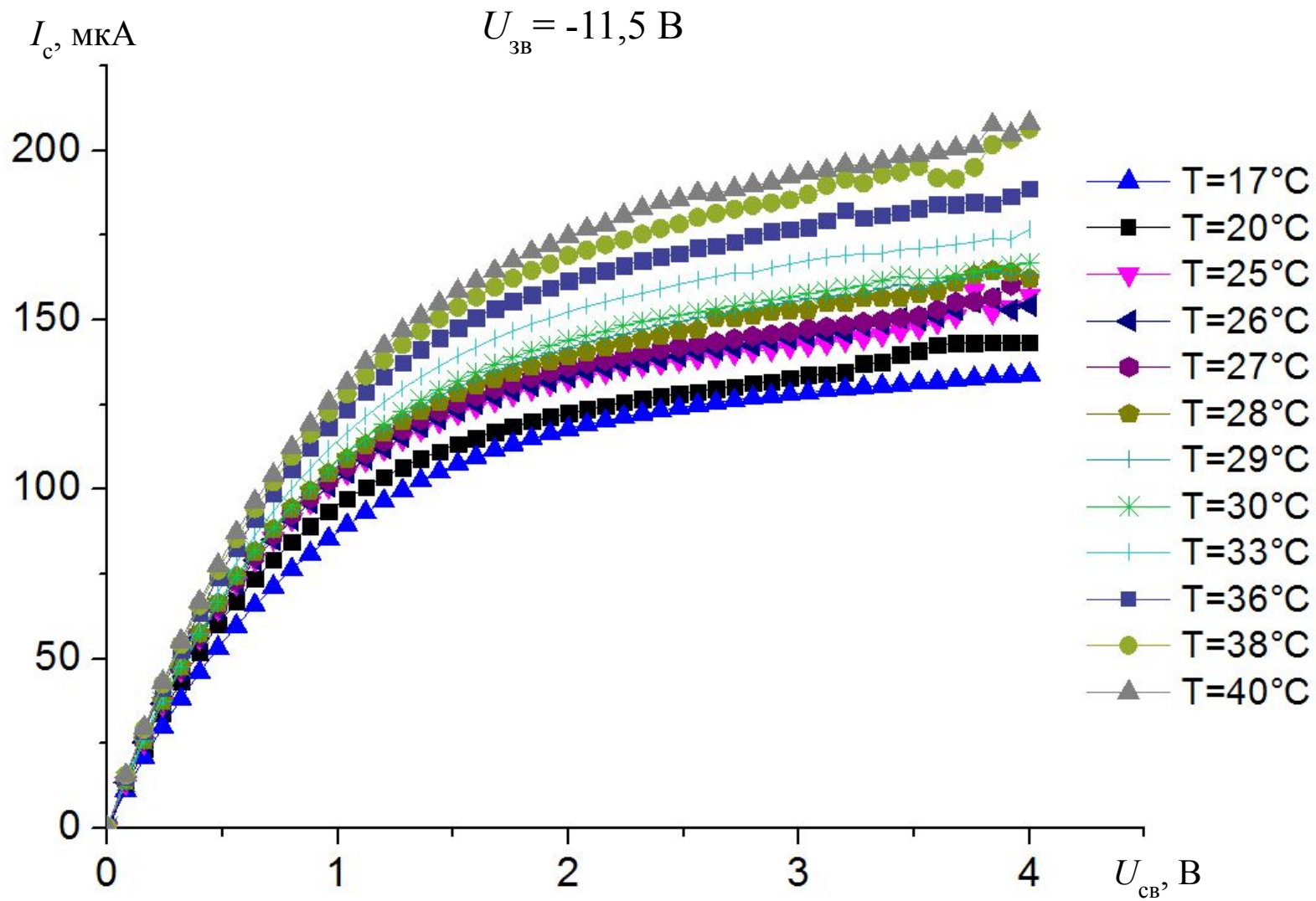

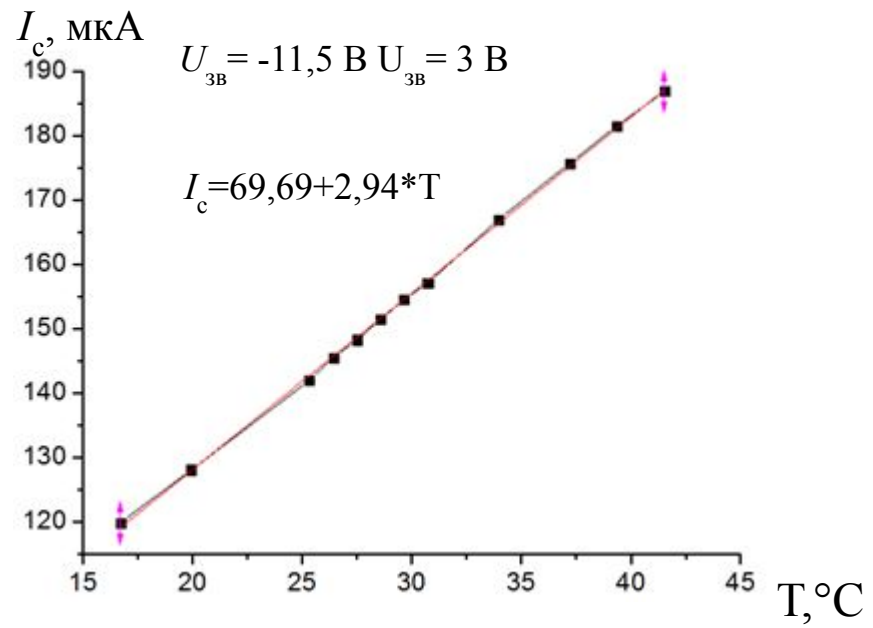

$I_c, \text{мкА}$

$U_{3B} = -5,0 \text{ В}, U_{CB} = 3,0 \text{ В}$

980
910
840
770
700
630
560
490
420
350
280
210
140
70
0

- Al_2O_3 — 0,00 мг/л
- Al_2O_3 — 0,25 мг/л
- Al_2O_3 — 1,0 мг/л
- Al_2O_3 — 2,5 мг/л
- Al_2O_3 — 10,0 мг/л
- Al_2O_3 — 25,0 мг/л

$I_c, \text{мкА}$

$U_{3B} = -5,0 \text{ В}, U_{CB} = -3,0 \text{ В}$

950
900
850
800
750
700
650

$U_{CB}, \text{В}$

$C, \text{мг/л}$

0,0

0,5

1,0

1,5

2,0

2,5

3,0

0

5

10

15

20

25

Для
Al₂O₃

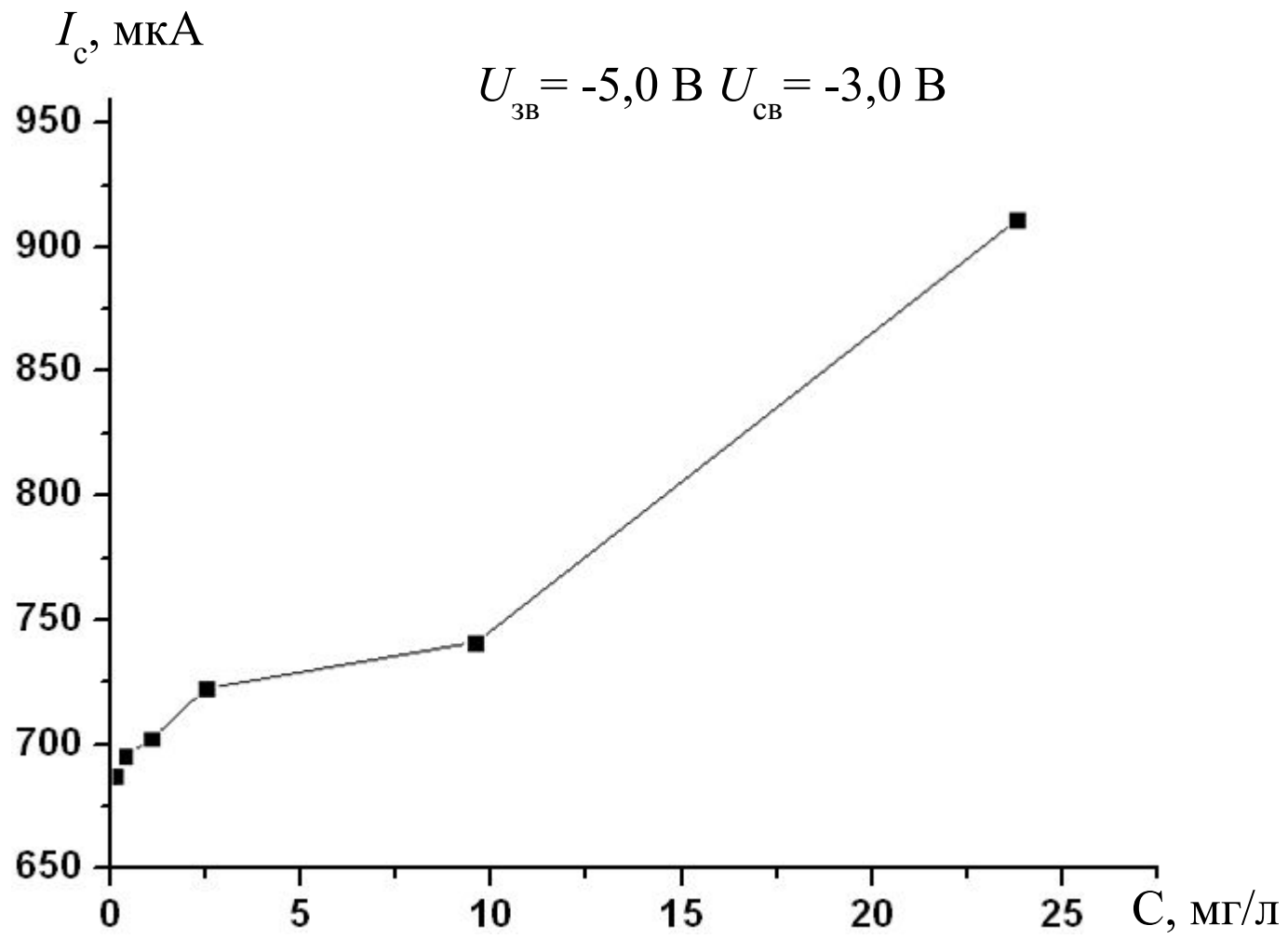

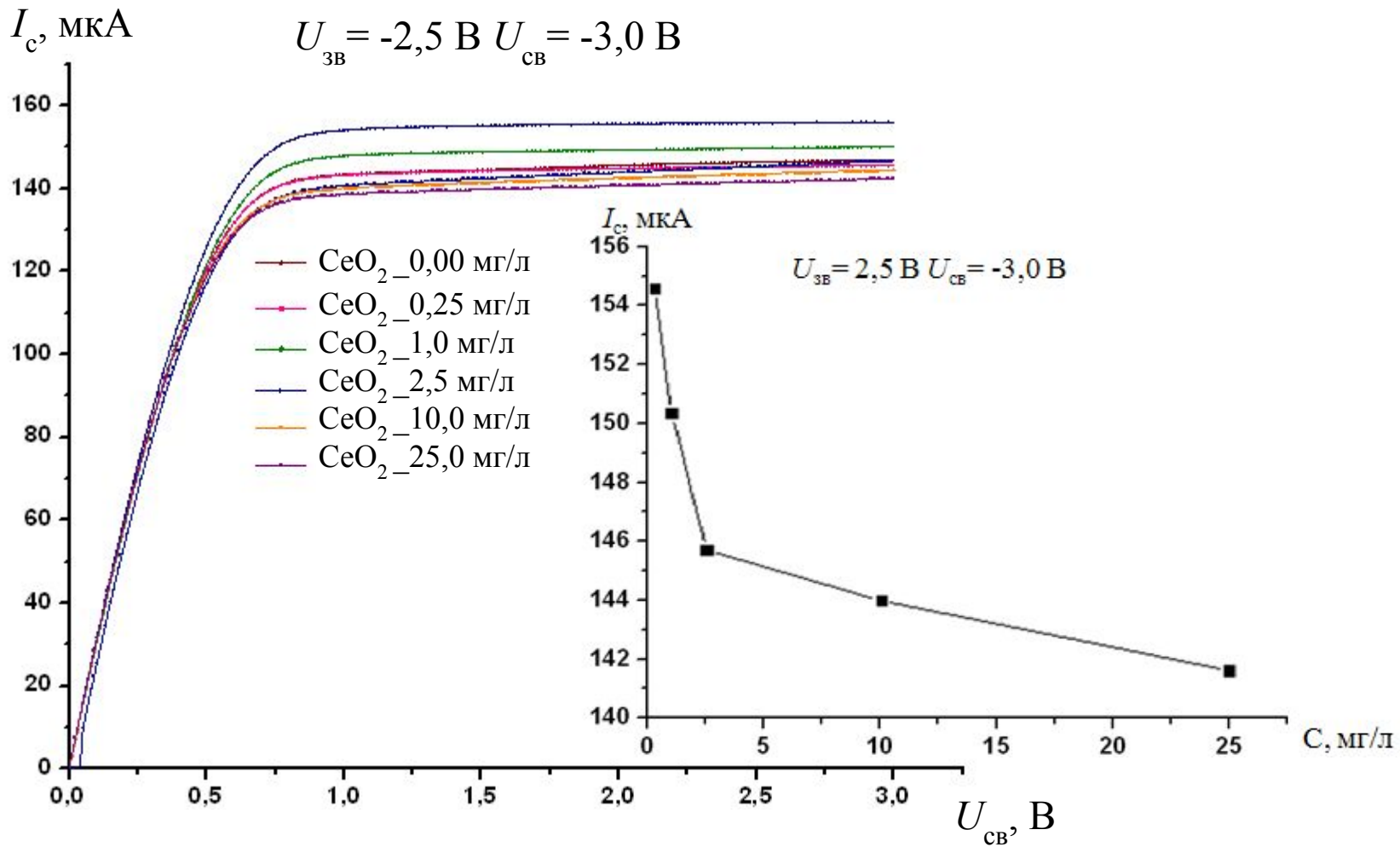

Для
CeO₂

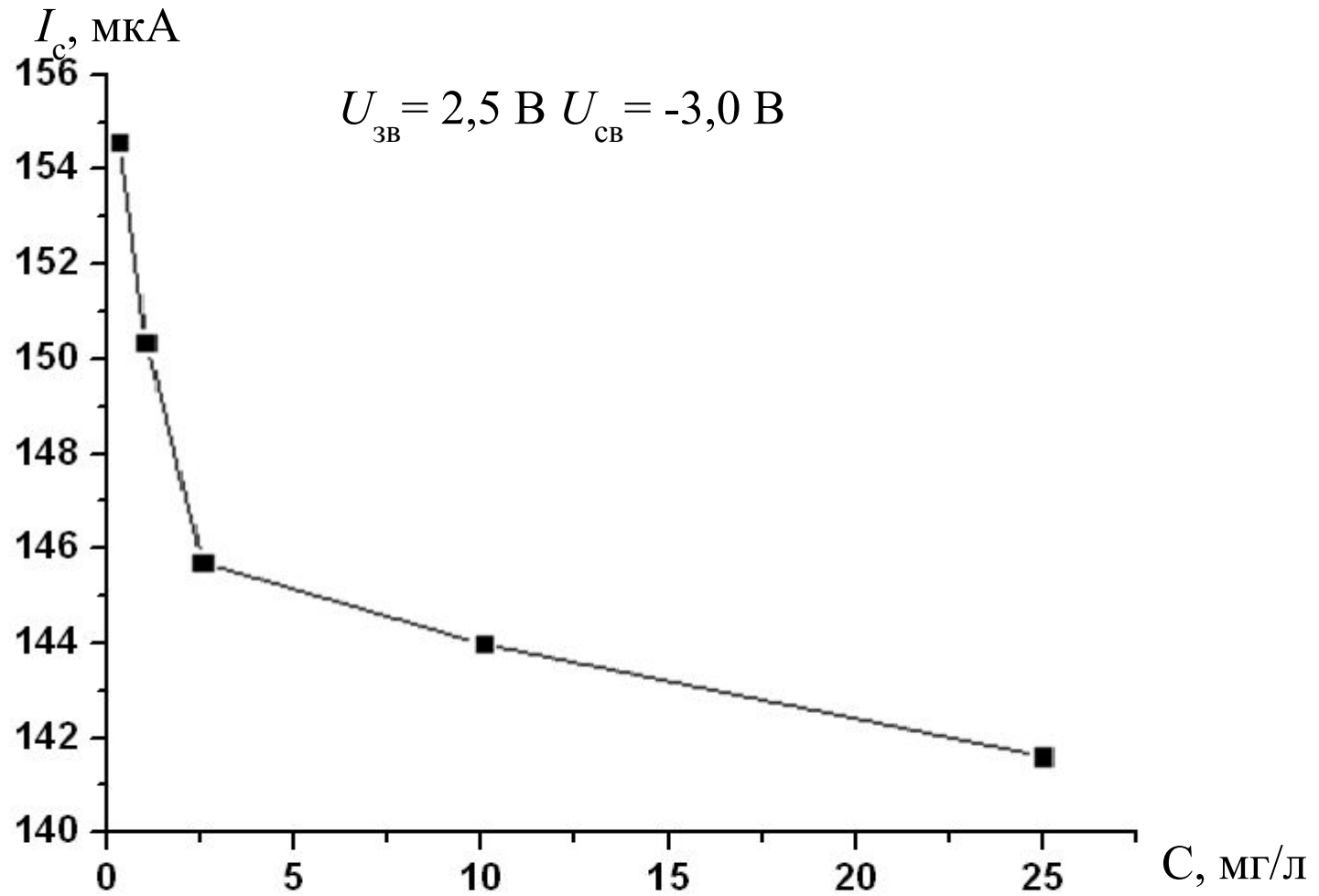

I_c , мкА

