



# Instrumentation Amplifier Noise Analysis



# SHORT RANGE OF BANDWIDTH



# Three Stage IA

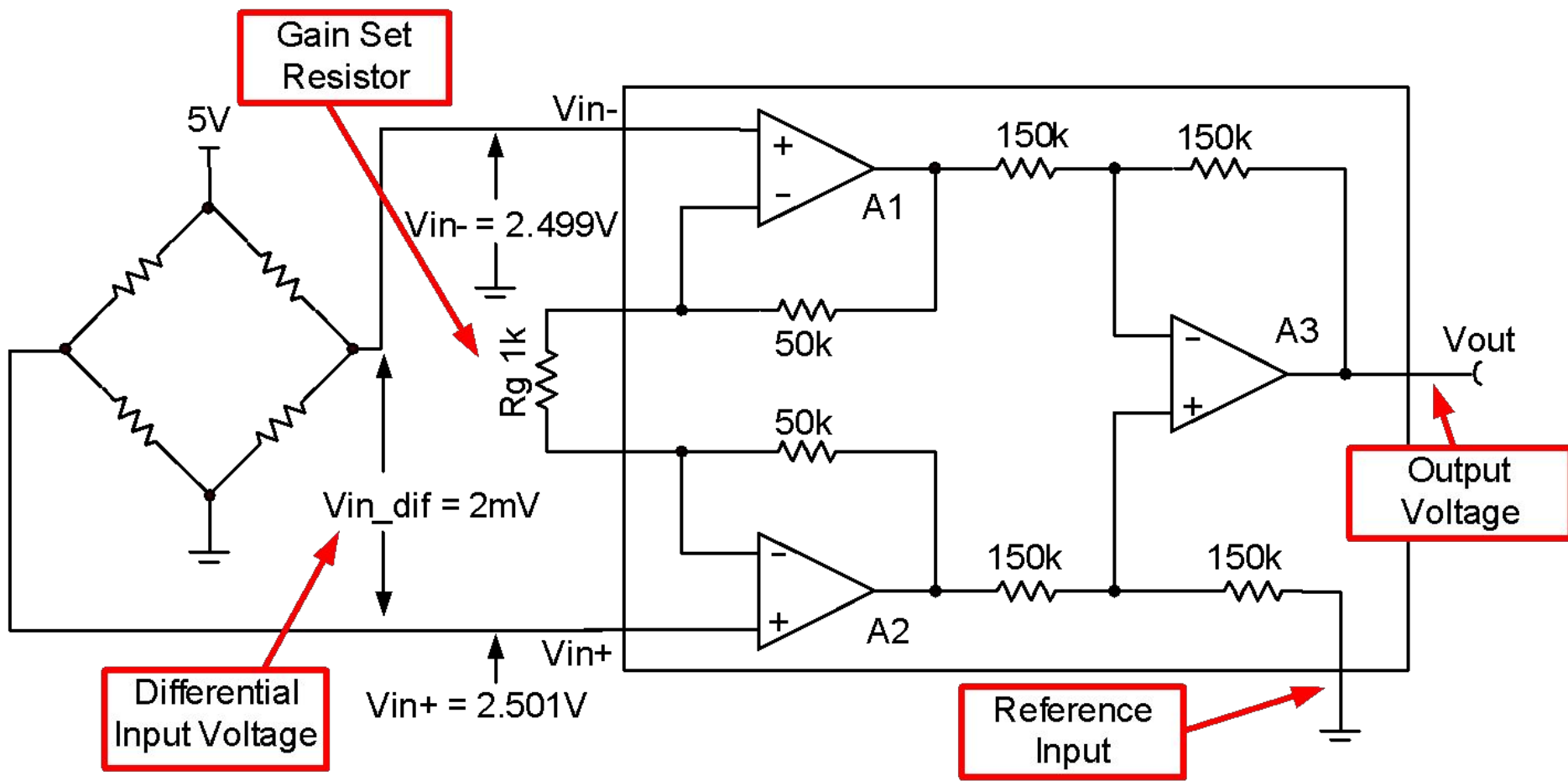



# Real World Input to Mathematical Model

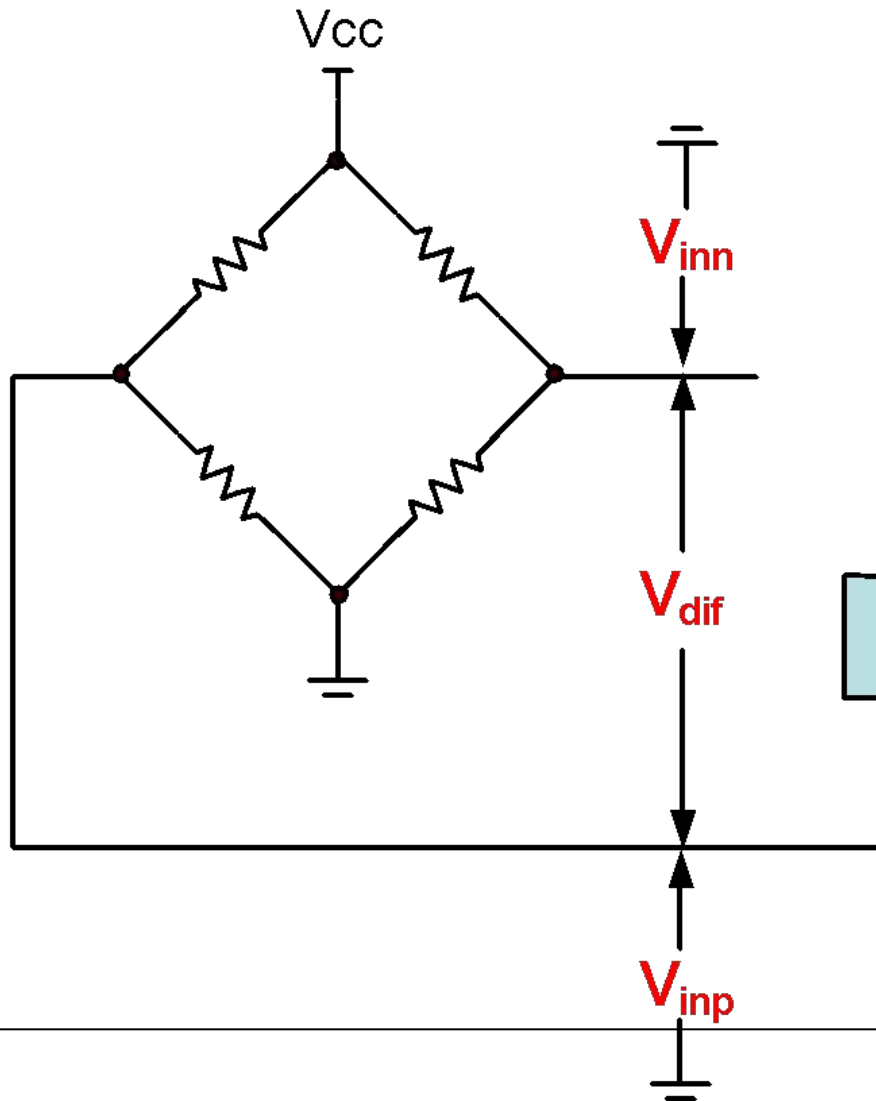

$$V_{cm} = \frac{V_{inp} + V_{inn}}{2}$$

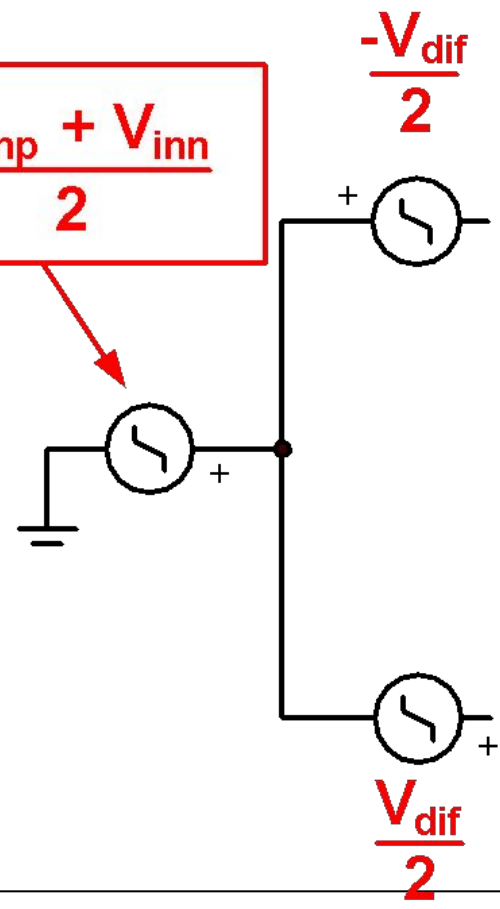
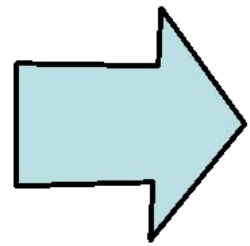



# Analyze the Input and Output Separately

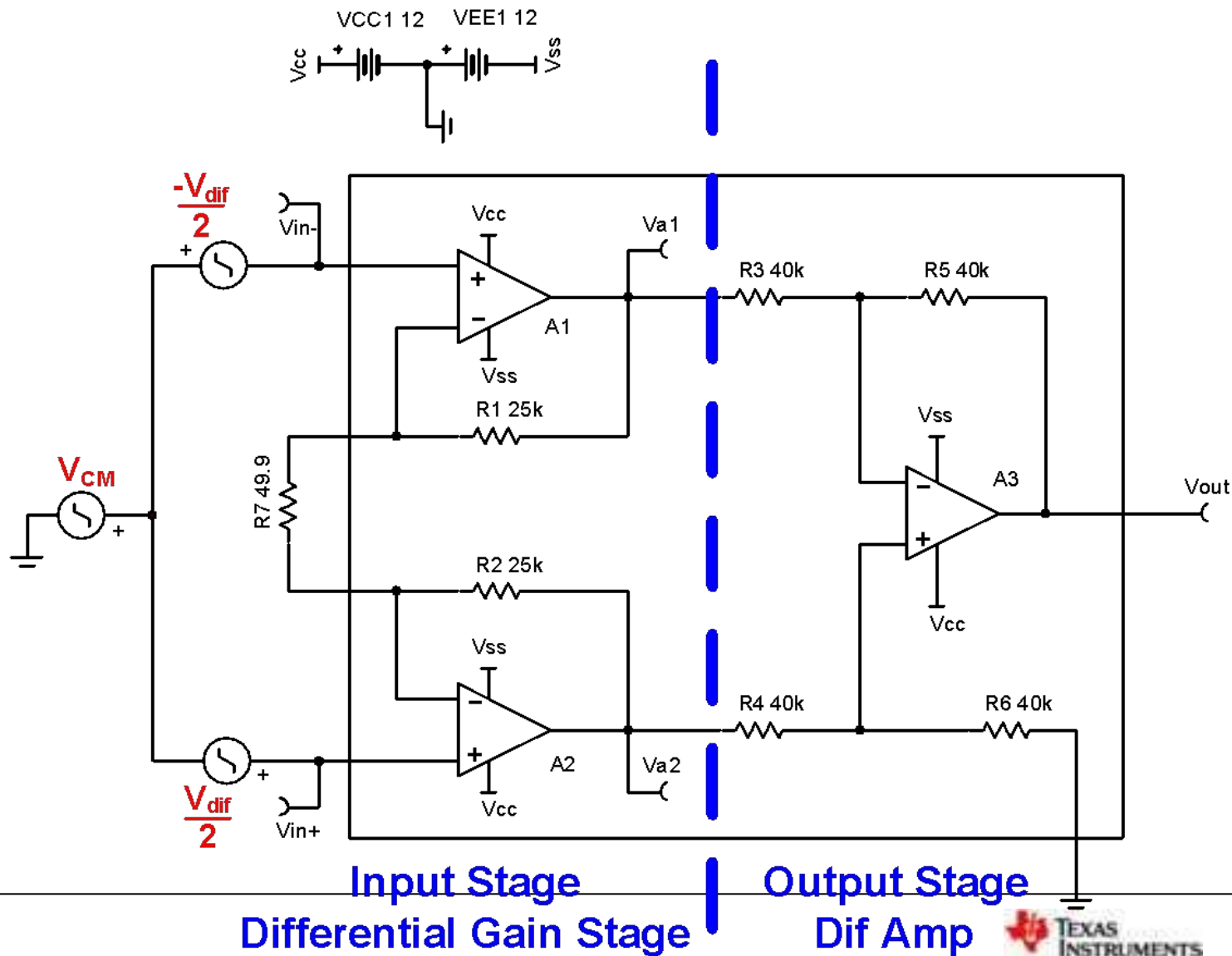

**Input Stage**  
**Differential Gain Stage**

**Output Stage**  
**Dif Amp**



# Split Input Stage in Half

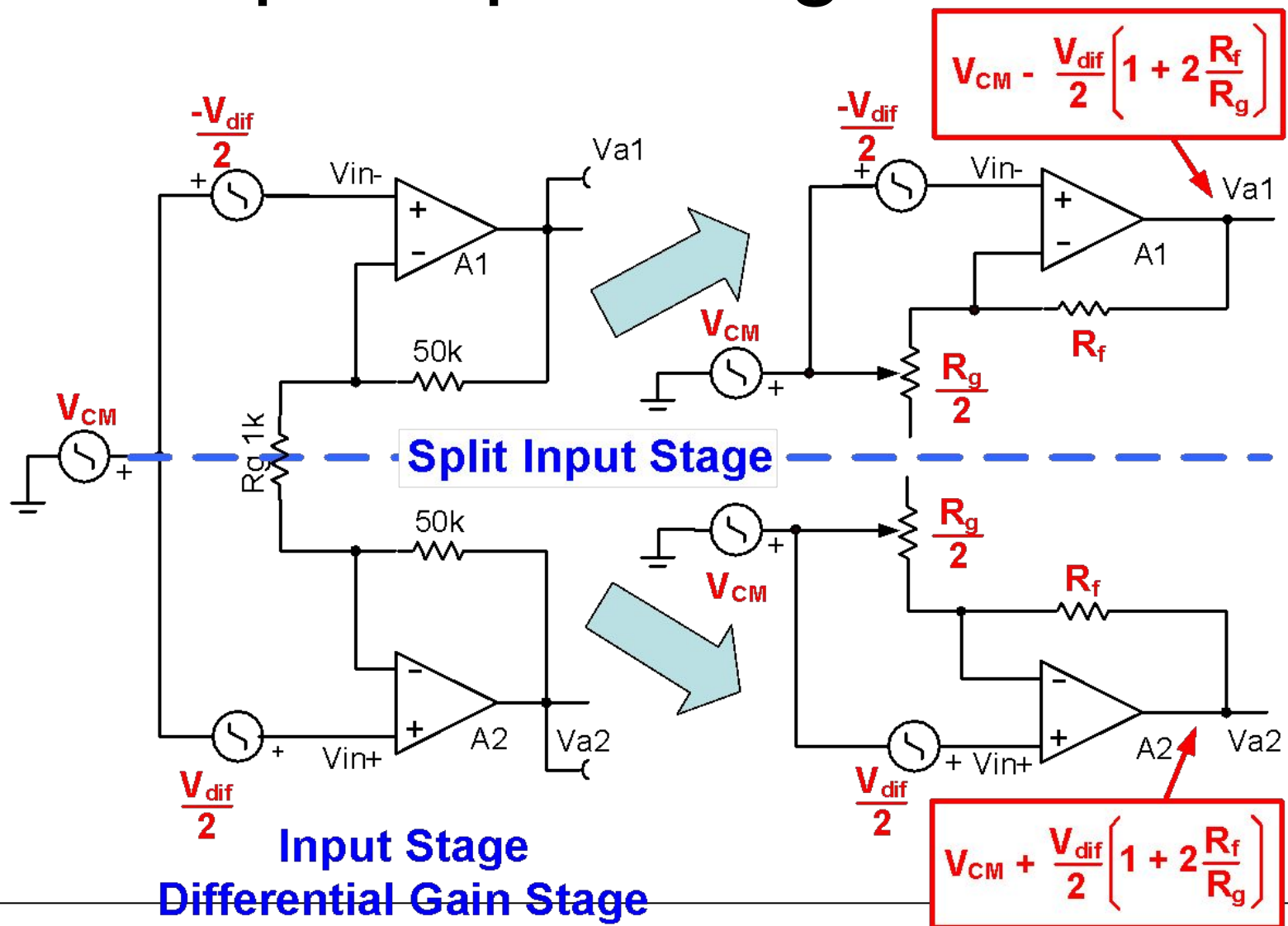



# Use Superposition on Output Amp

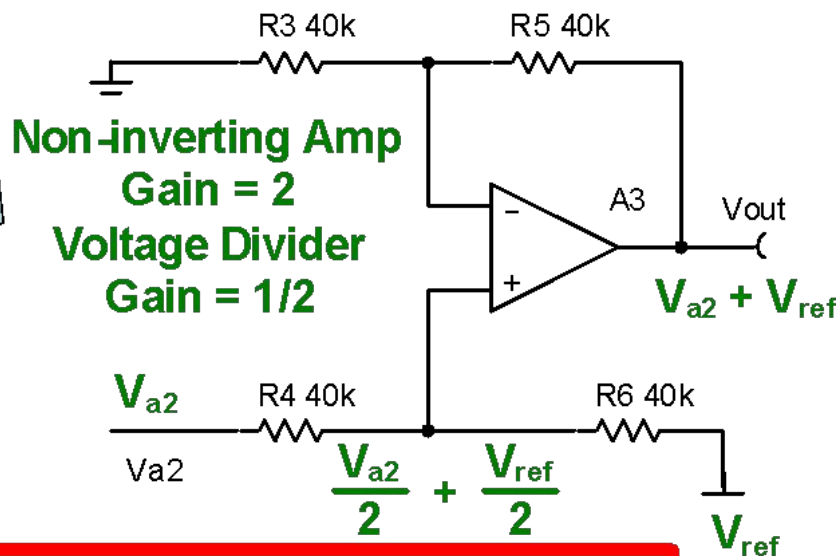
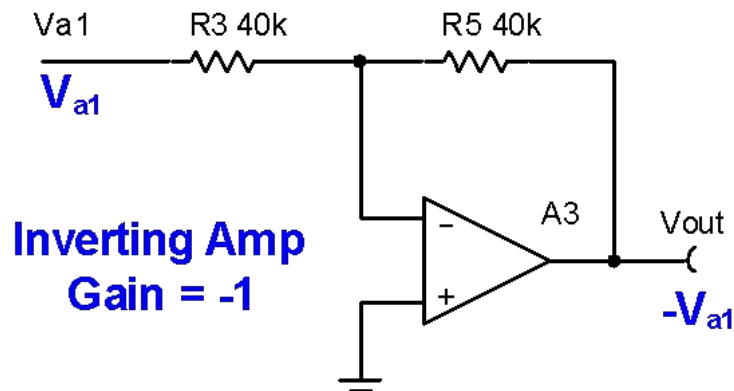
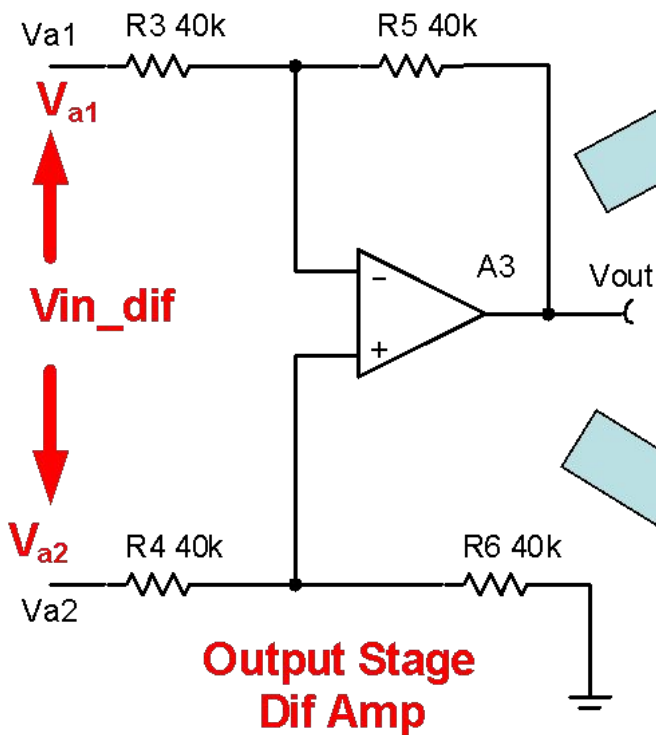

**Find Vout Through Superposition**

$$V_{out} = V_{a2} - V_{a1} + V_{ref}$$



# Gain For Three Amp IA

$$V_{a1} = V_{cm} - \frac{V_{dif}}{2} \cdot \left( 1 + 2 \frac{R_f}{R_g} \right) \quad \text{[1] Input Stage Top Half}$$

$$V_{a2} = V_{cm} + \frac{V_{dif}}{2} \cdot \left( 1 + 2 \frac{R_f}{R_g} \right) \quad \text{[2] Input Stage Bottom Half}$$

$$V_{out} = V_{a2} - V_{a1} + V_{ref} \quad \text{[3] Output Stage}$$

$$V_{out} = \left[ V_{cm} + \frac{V_{dif}}{2} \cdot \left( 1 + 2 \frac{R_f}{R_g} \right) \right] - \left[ V_{cm} - \frac{V_{dif}}{2} \cdot \left( 1 + 2 \frac{R_f}{R_g} \right) \right] + V_{ref} \quad \text{Substitute [1] and [2] into [3]}$$

$$V_{out} = V_{dif} \left( 1 + 2 \frac{R_f}{R_g} \right) + V_{ref} \quad \text{[4] Simplify}$$





MESSAGE FROM THE BOARD



# Complex Noise Model

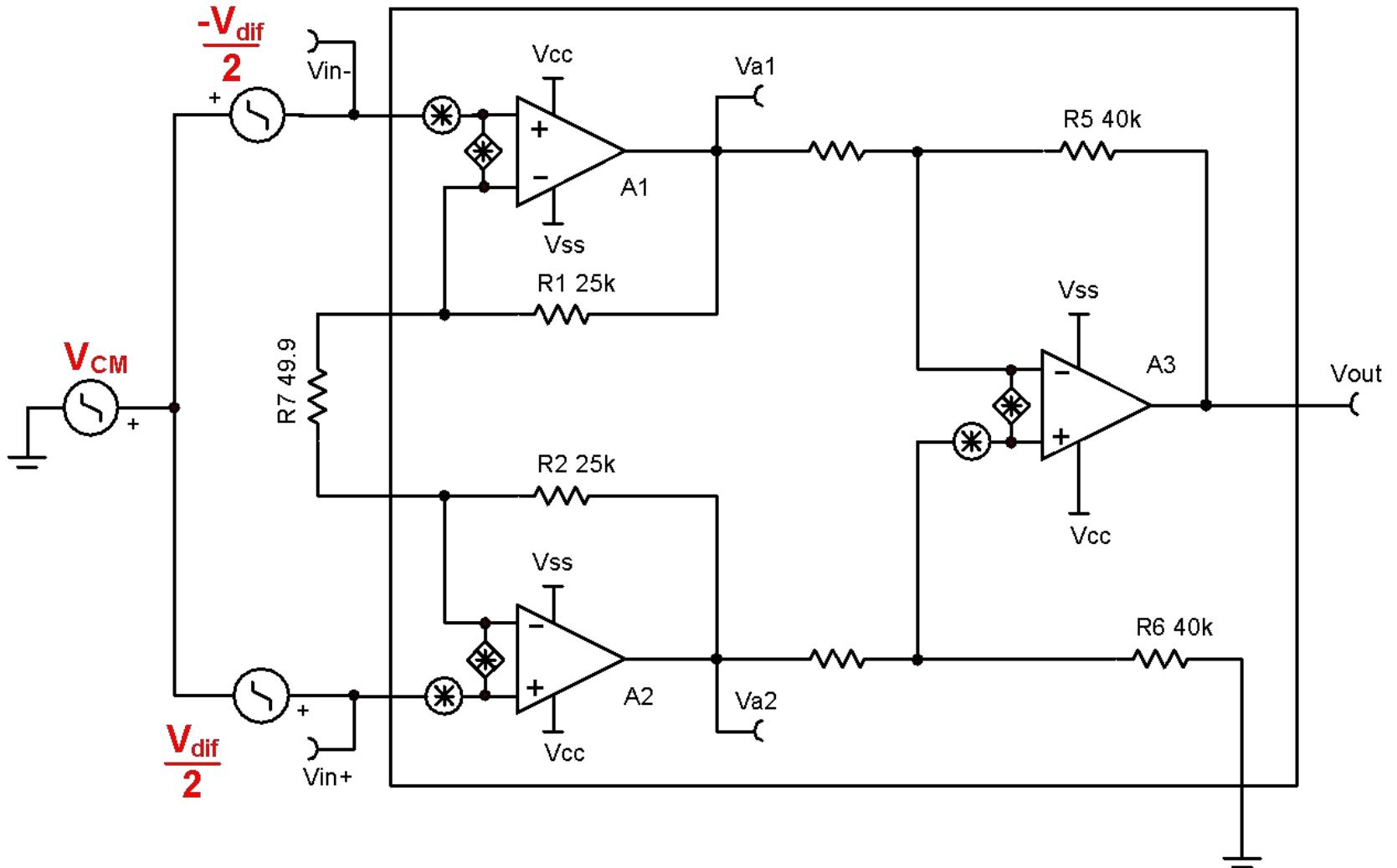



# The Complex Model is Simplified

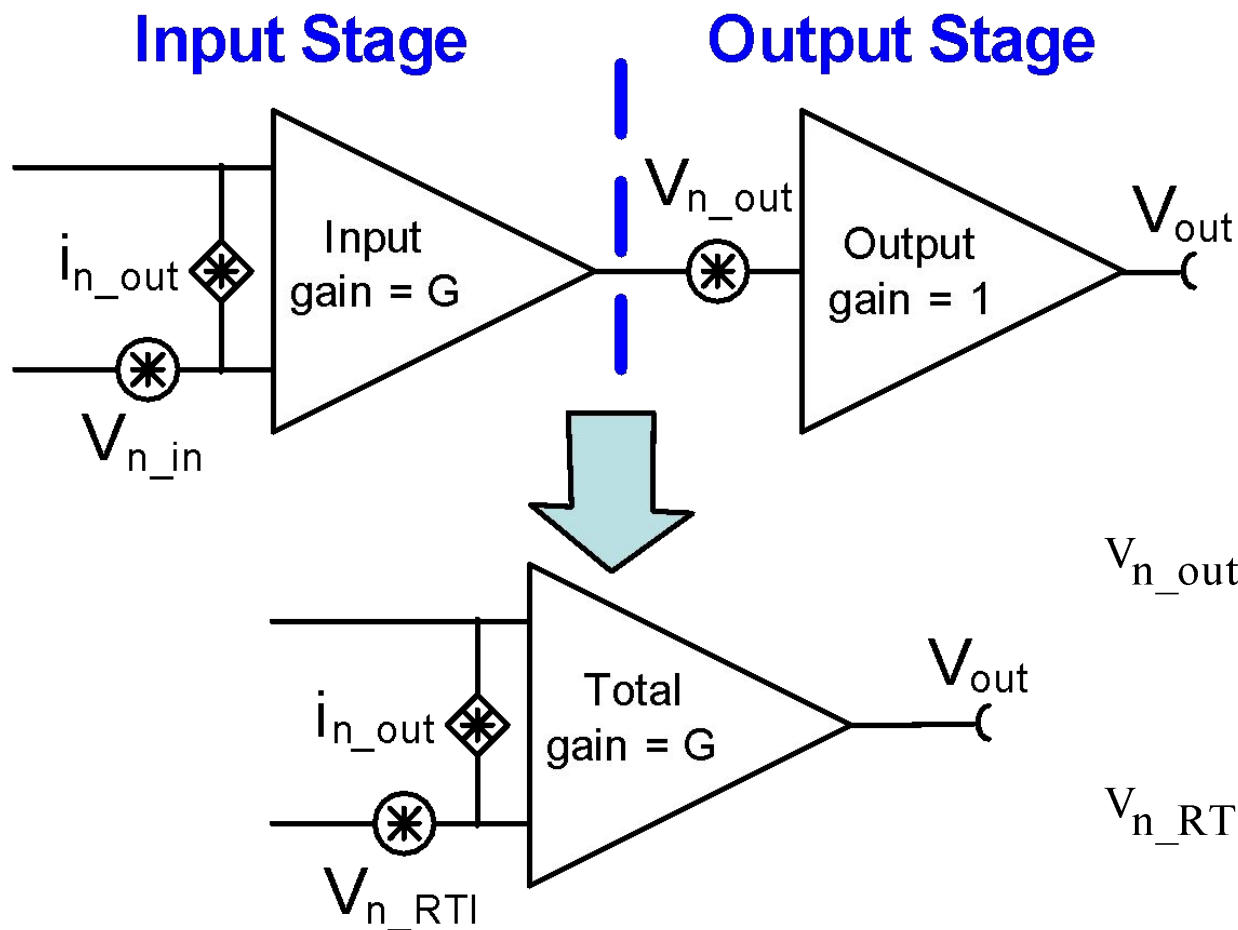

$$V_{n\_out} = \sqrt{(V_{n\_out})^2 + (V_{n\_in} \cdot G)^2}$$

$$V_{n\_RTI} = \sqrt{\left(\frac{V_{n\_out}}{G}\right)^2 + (V_{n\_in})^2}$$



# The Input amplifier dominates at High Gain

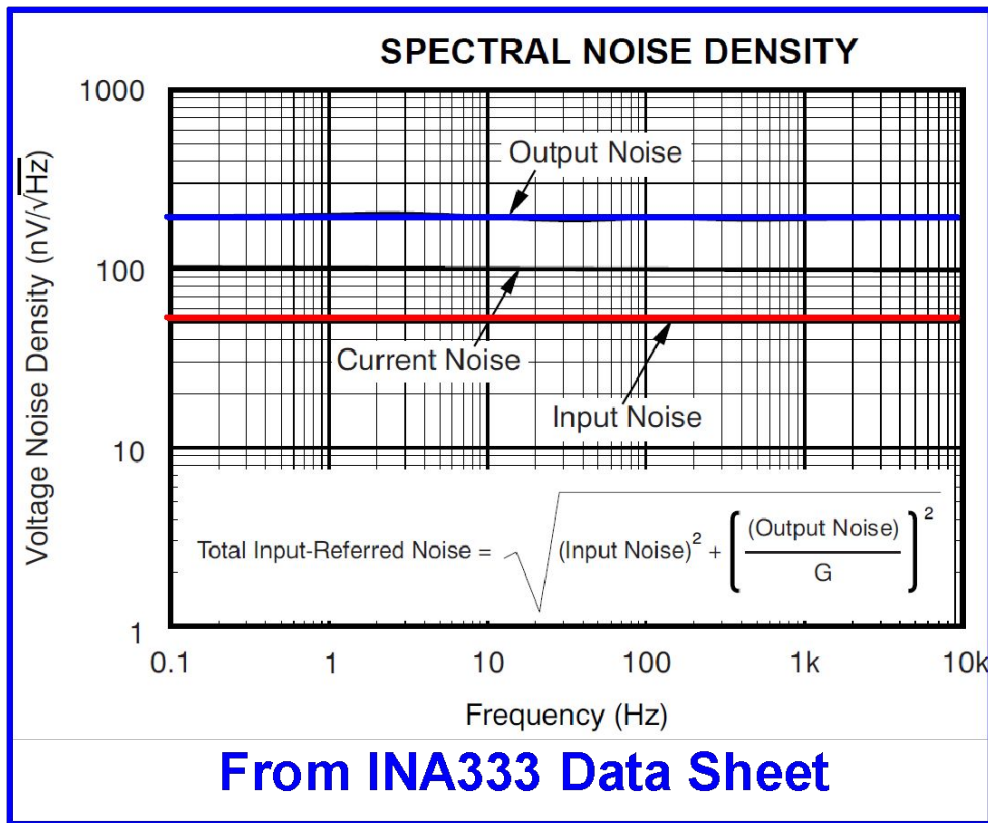

G	Total Input-Referr ed Noise (nV/rtHz)	Total Output Noise (nV/rtHz)
1	206.2	206.2
2	111.8	223.6
5	64	320
10	53.9	539
100	50	5000
1000	50	50,000



# Two Ways to represent INA Spectral Density

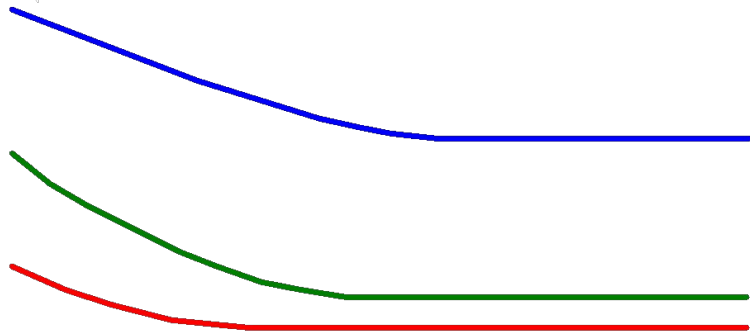

From INA128 Data Sheet

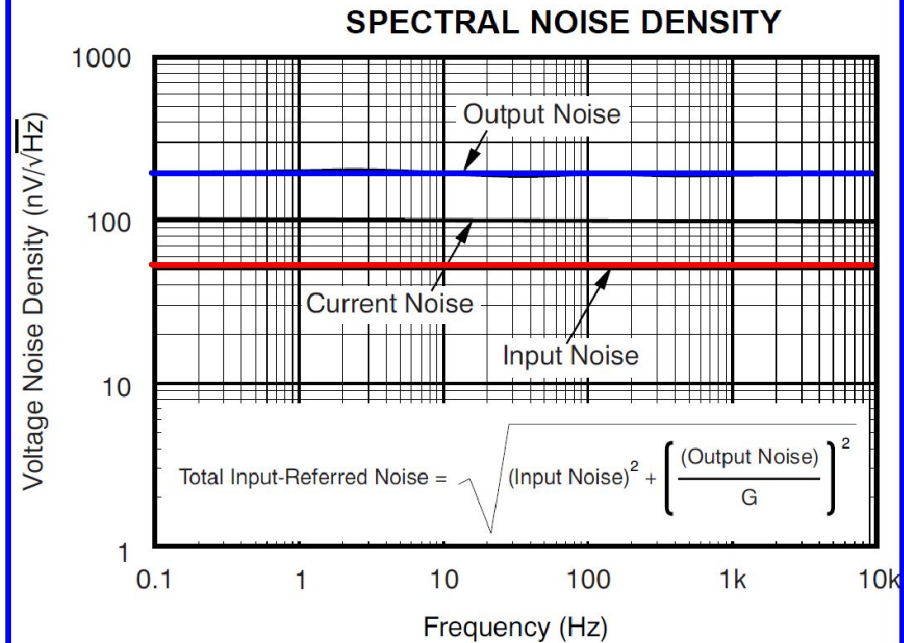

From INA333 Data Sheet

G	Input-Referred Noise (nV/rtHz)
1	110
10	12
100	8
1000	8

Taken directly from the graph

G	Input-Referred Noise (nV/rtHz)
1	206.2
10	53.9
100	50
1000	50

Calculated using graphs and formula



Handwritten Analysis of Grammar



# Find the total RMS Noise Voltage at the Output

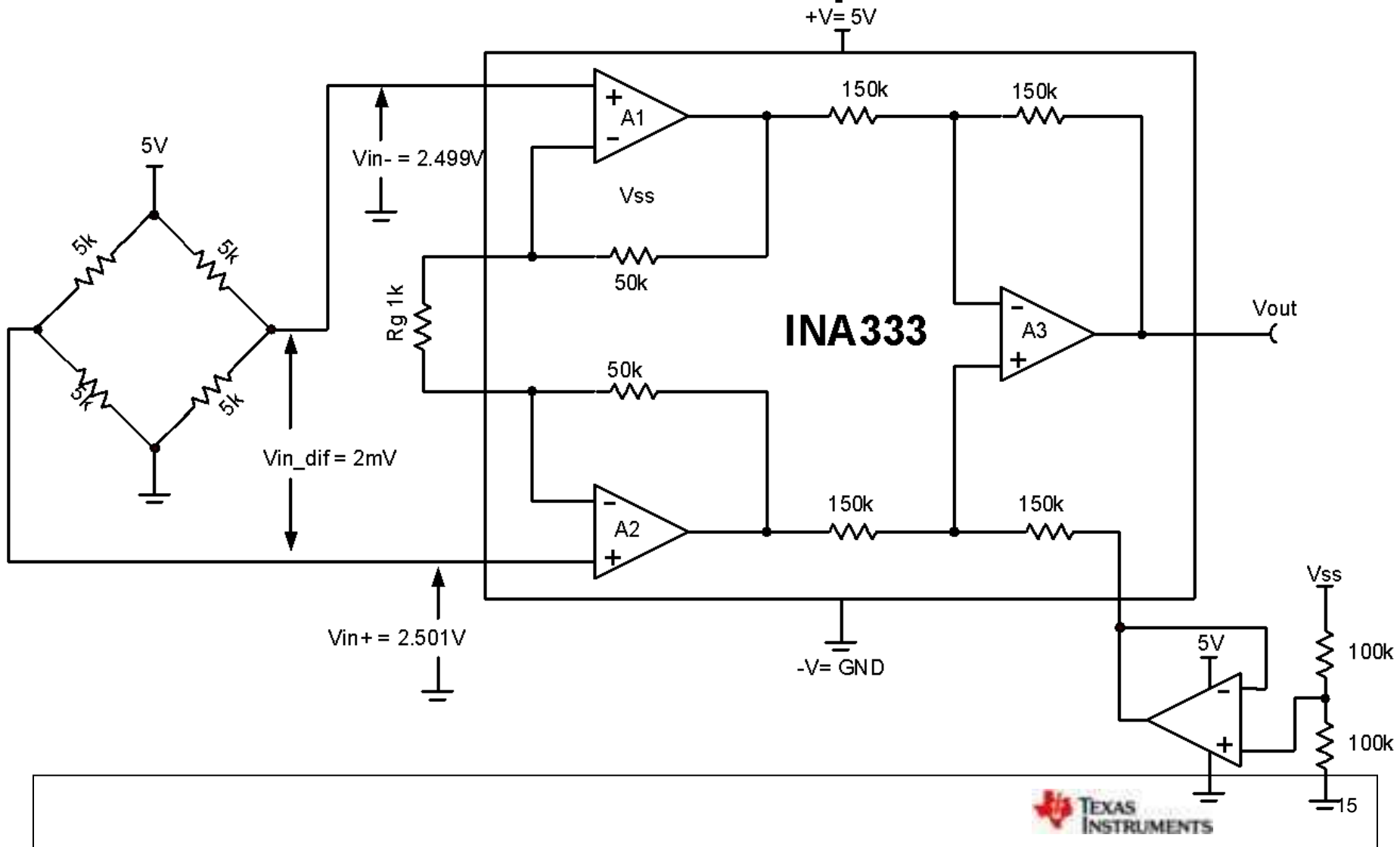



# Look at Noise Sources: Bridge, INA333, Reference Buffer

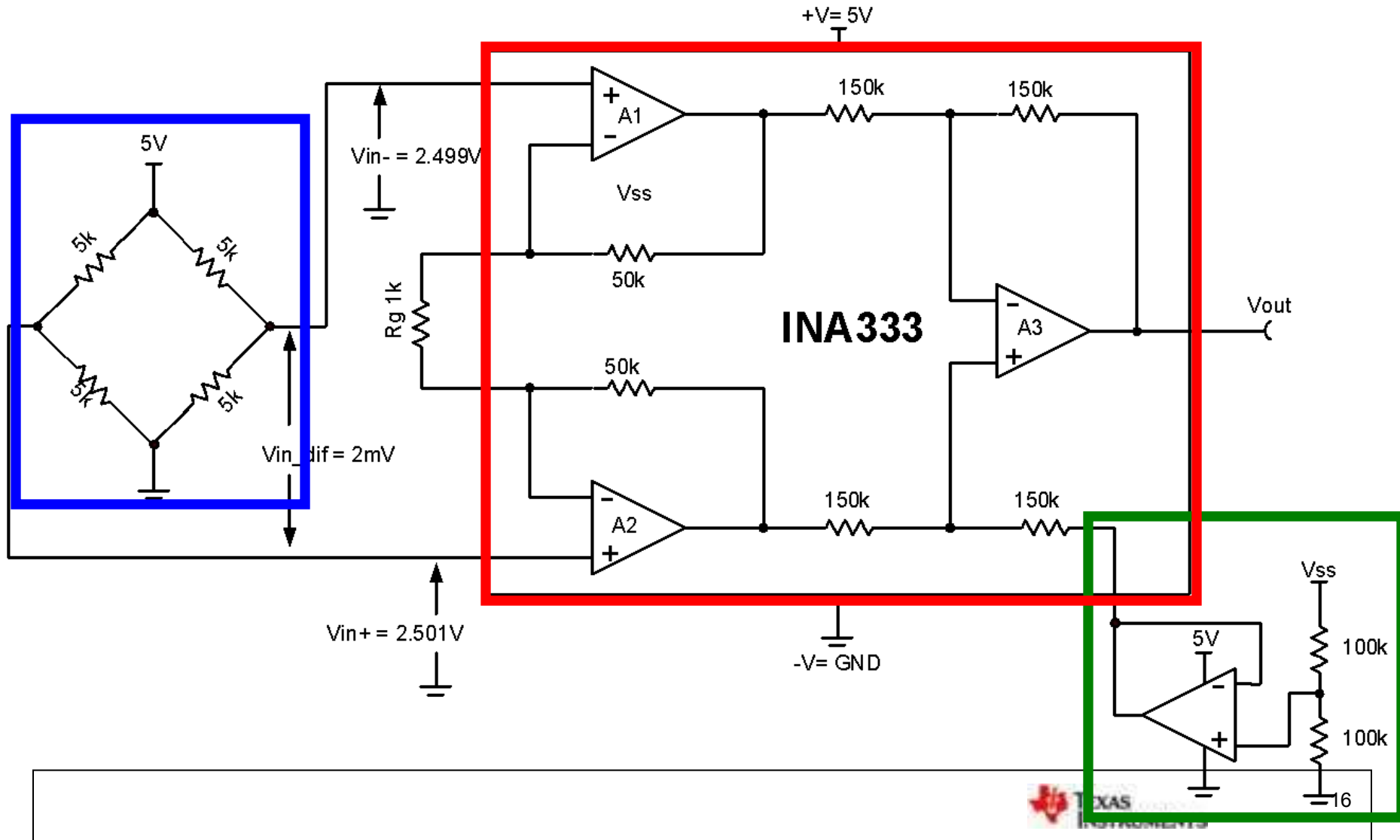





# Noise Equivalent Model for Reference Pin Buffer

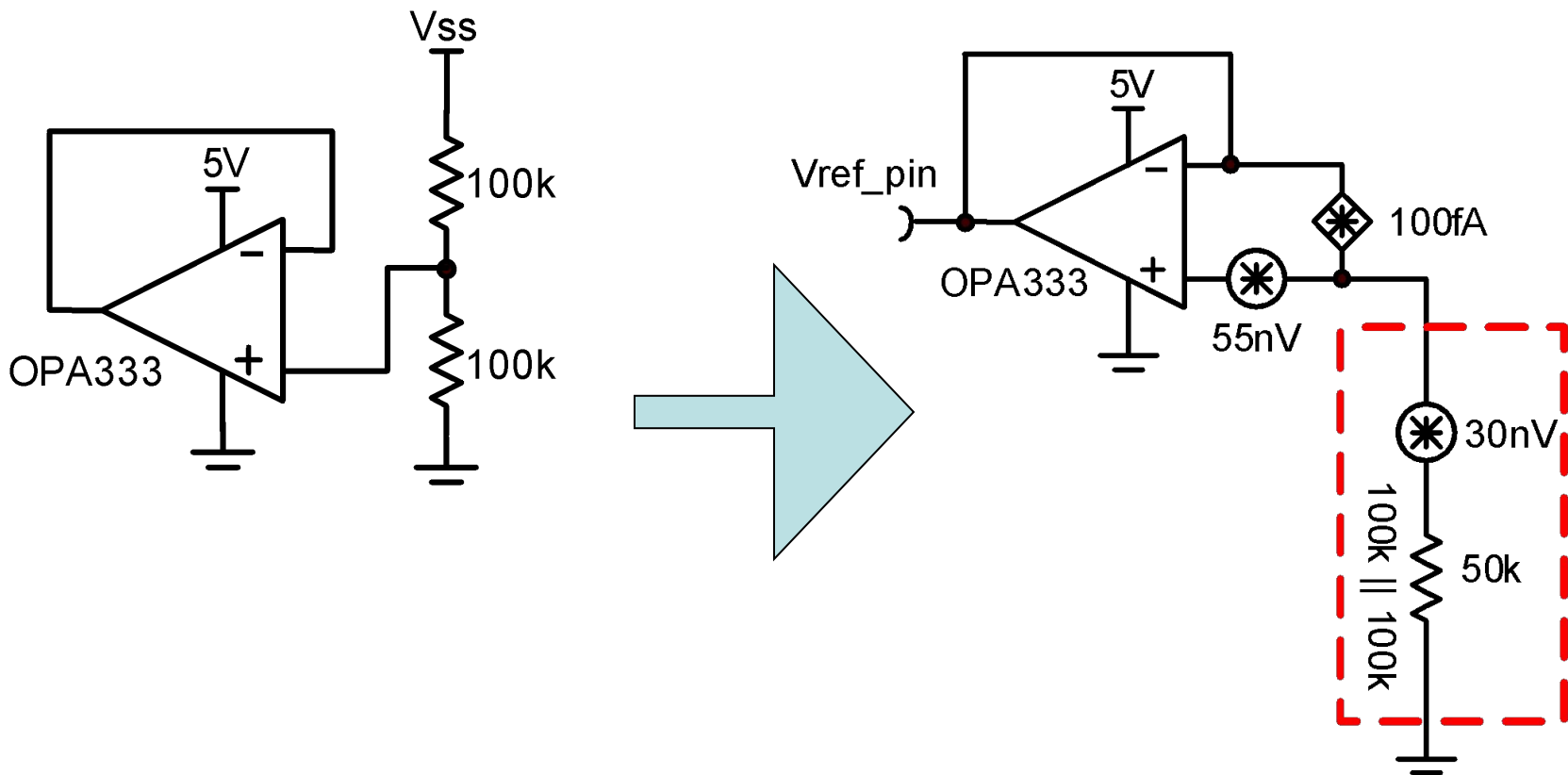



# Reference buffer

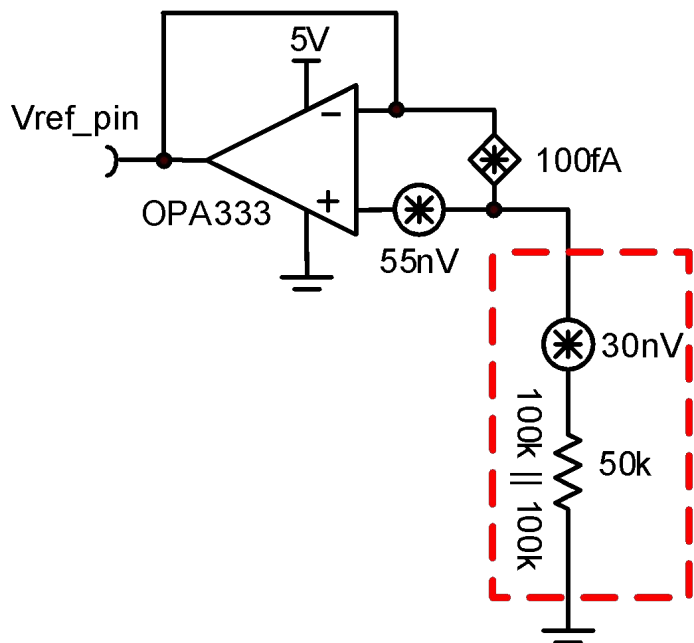

$$k_n = 1.38 \cdot 10^{-23} \quad \text{Boltzmann's constant}$$

$$T_k = 273 + 25 \quad \text{Temperature in Kelvin}$$

$$R_{eq} = 50k\Omega \quad \text{Input resistance (parallel combination of voltage divider)}$$

$$e_{n_r} = \sqrt{4k_n \cdot T_n \cdot R_{eq}} = 28.7 \frac{\text{nV}}{\sqrt{\text{Hz}}} \quad \text{Thermal Noise from input resistor}$$

$$i_n = 100\text{fA} \quad \text{Current noise from OPA333}$$

$$e_{n_i} = i_n \cdot R_{eq} = 5 \frac{\text{nV}}{\sqrt{\text{Hz}}} \quad \text{Voltage Noise from current noise}$$

$$e_{n_{opa}} = 55 \frac{\text{nV}}{\sqrt{\text{Hz}}} \quad \text{Voltage noise from OPA333}$$

$$e_{n_{ref}} = \sqrt{e_{n_{opa}}^2 + e_{n_r}^2 + e_{n_i}^2} = 62.2 \frac{\text{nV}}{\sqrt{\text{Hz}}} \quad \text{Total rms noise from reference driver circuit}$$



# The reference voltage directly adds to the output noise

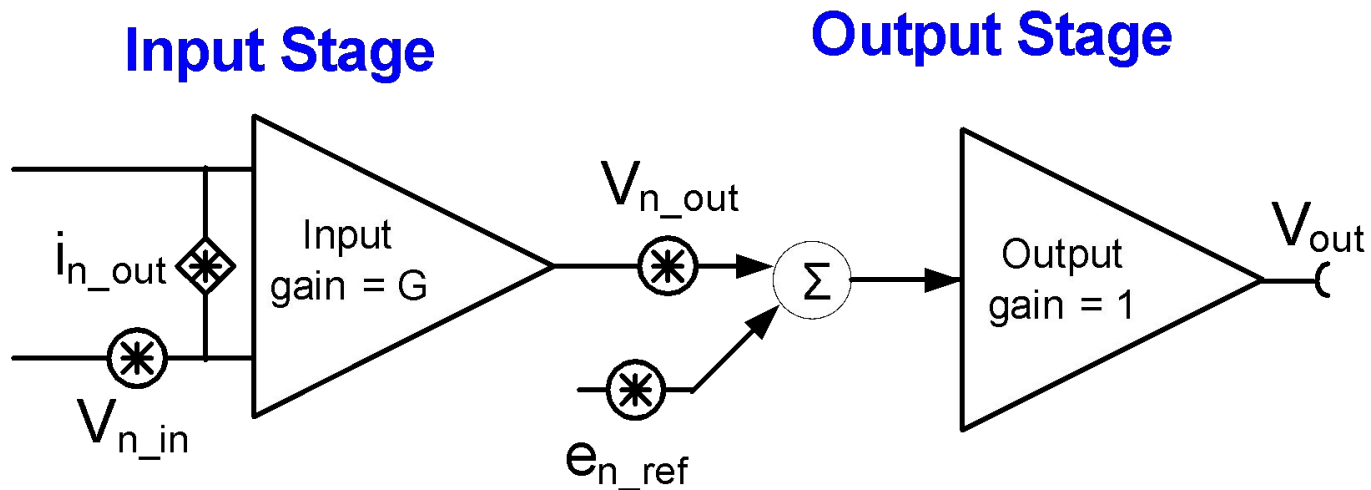

$$e_{n\_ref} := 62.2 \cdot 10^{-9} \quad V_{n\_out} := 200 \cdot 10^{-9}$$

$$\text{Output\_Stage\_Noise} := \sqrt{e_{n\_ref}^2 + V_{n\_out}^2} = 209.449 \times 10^{-9}$$



# The bridge generates: thermal noise, $i_n \times R_{\text{bridge}}$

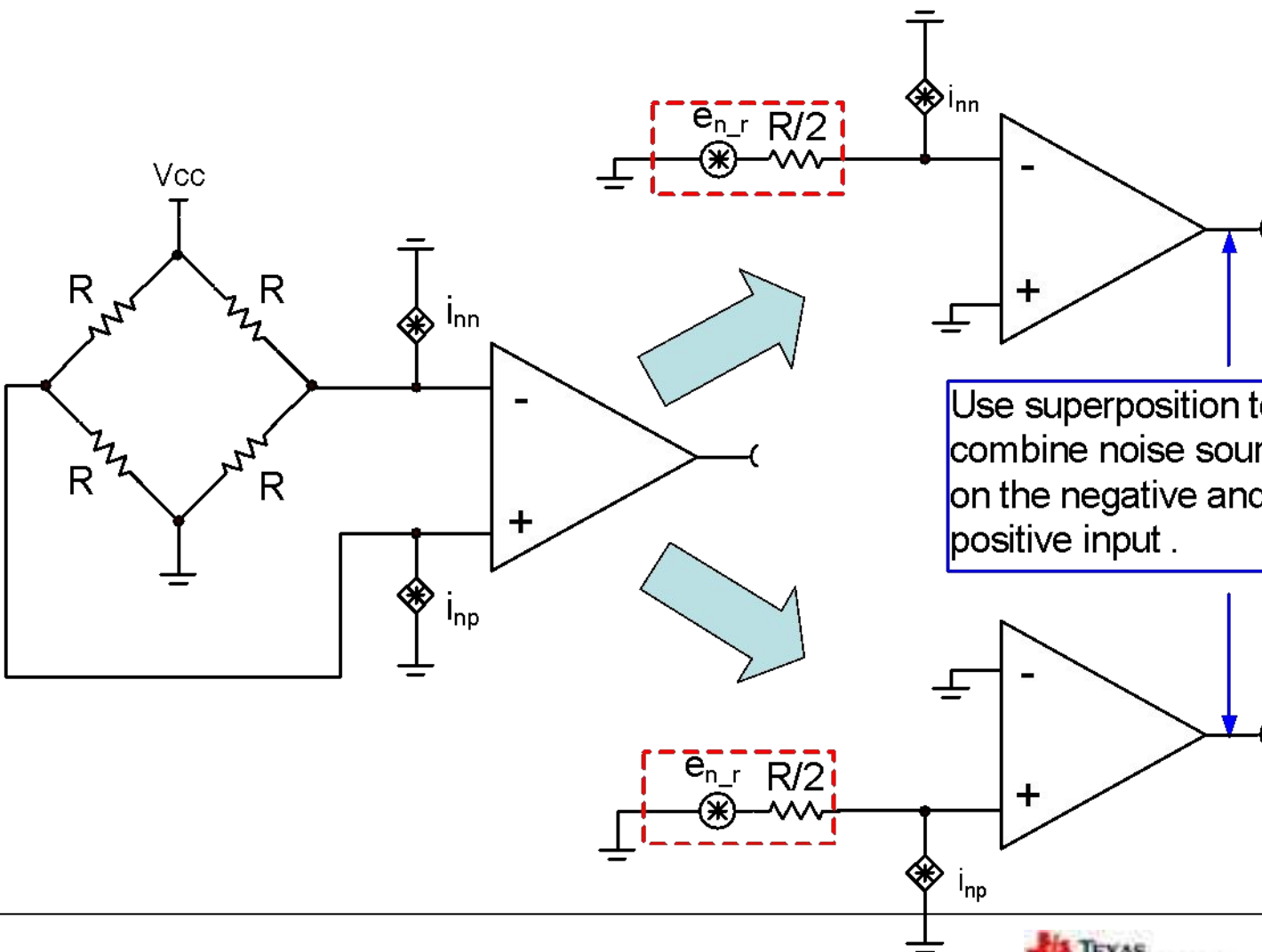



# Noise From Bridge / Current Sources

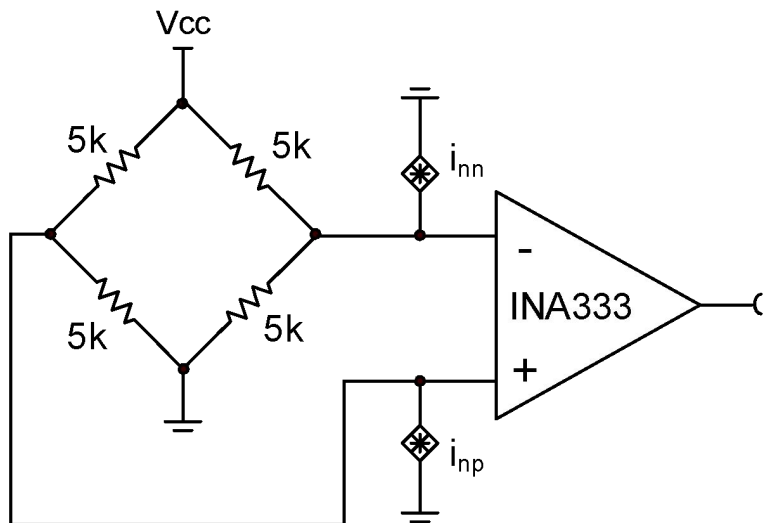

$$i_{nn} \cdot \frac{R}{2} \quad \text{Voltage noise from current noise}$$

$$e_{n\_rb} = \sqrt{4k_n \cdot T_n \cdot \frac{R}{2}} \quad \text{Resistor Noise}$$

Use superposition to add the noise from the input resistance and both current noise sources

$$e_{in\_i} = \sqrt{\left(i_{nn} \cdot \frac{R}{2}\right)^2 + (e_{n\_rb})^2 + \left(i_{np} \cdot \frac{R}{2}\right)^2 + (e_{n\_rb})^2}$$

$$\text{Assume } |i_{nn}| = |i_{np}|$$

Note that these sources are uncorrelated

$$e_{in\_i} = \sqrt{2\left(i_n \cdot \frac{R}{2}\right)^2 + 2(e_{n\_rb})^2} \quad \text{Total Noise from input resistors and current source}$$

For this example ( $R=5k\Omega$ ,  $i_n = 100fA/\sqrt{Hz}$ )

$$e_{n\_rb} = 6.4 \frac{nV}{\sqrt{Hz}} \quad \text{Resistor noise}$$

$$i_{nn} \cdot \frac{R}{2} = 0.25 \frac{nV}{\sqrt{Hz}} \quad \text{Voltage noise from current noise}$$

$$e_{in\_i} = \sqrt{2(0.25)^2 + 2(6.4)^2} = 9.1 \frac{nV}{\sqrt{Hz}} \quad \text{Total Noise from input resistors and current source}$$





# Combine all the noise sources

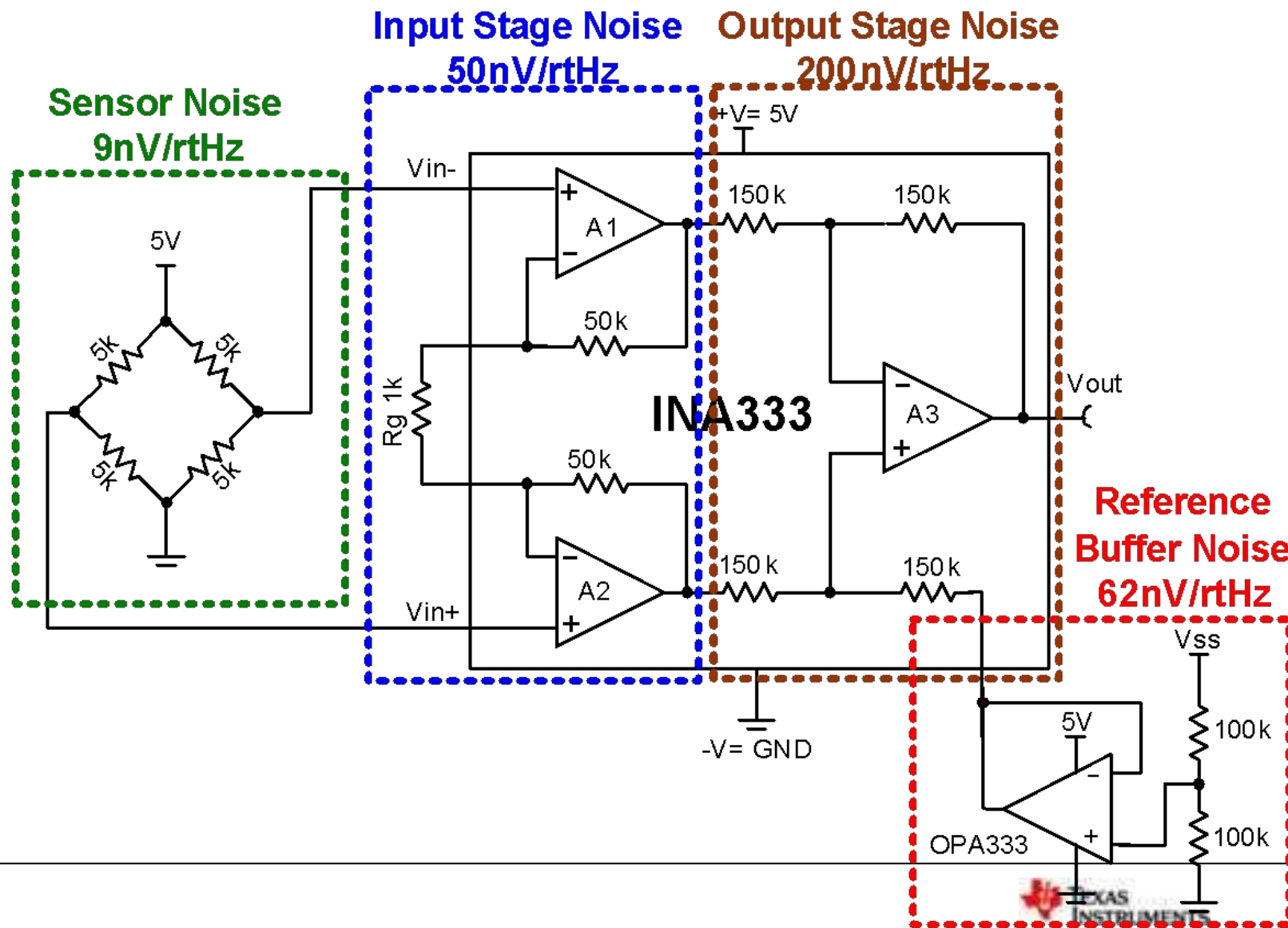



# Rule of 3x

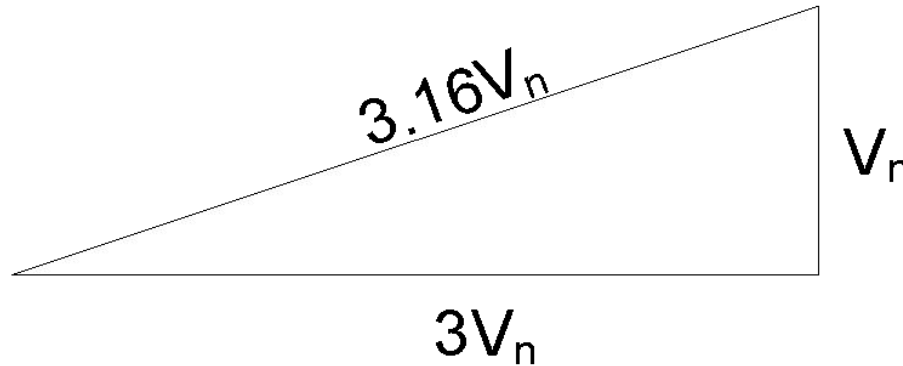

$$\sqrt{\underbrace{(3 \cdot V_n)^2}_{\text{Dominant}} + \underbrace{V_n^2}_{\text{Neglect}}} = \sqrt{9 \cdot V_n^2 + V_n^2} = 3.16V_n$$

When adding two uncorrelated noise terms, the larger term will dominate if it is 3 times larger than the smaller term. You can neglect the smaller term with a relatively small error (i.e. 6%).



For this example compute noise spectral density referred to the input

$$\text{Noise\_Spec\_Den\_RTI} = \sqrt{V_{n\_in\_stage}^2 + V_{n\_bridge}^2 + \left(\frac{V_{n\_out\_stage}}{G}\right)^2 + \left(\frac{V_{n\_ref\_buf}}{G}\right)^2}$$

$$\text{Noise\_Spec\_Den\_RTI} = \sqrt{\underbrace{(50)^2}_{\text{Dominant}} + \underbrace{(9)^2 + \left(\frac{200}{100}\right)^2 + \left(\frac{62}{100}\right)^2}_{\text{Neglect}} = \underbrace{50.847}_{\text{Approximately equal to the dominant term}} \frac{\text{nV}}{\sqrt{\text{Hz}}}$$





PARAMETER	INA333			UNIT
	MIN	TYP	MAX	
<b>FREQUENCY RESPONSE</b>				
Bandwidth, -3dB				
G = 1		150		kHz
G = 10		35		kHz
G = 100		3.5		kHz
G = 1000		350		Hz

Bandwidth from Data Sheet

### GAIN vs FREQUENCY

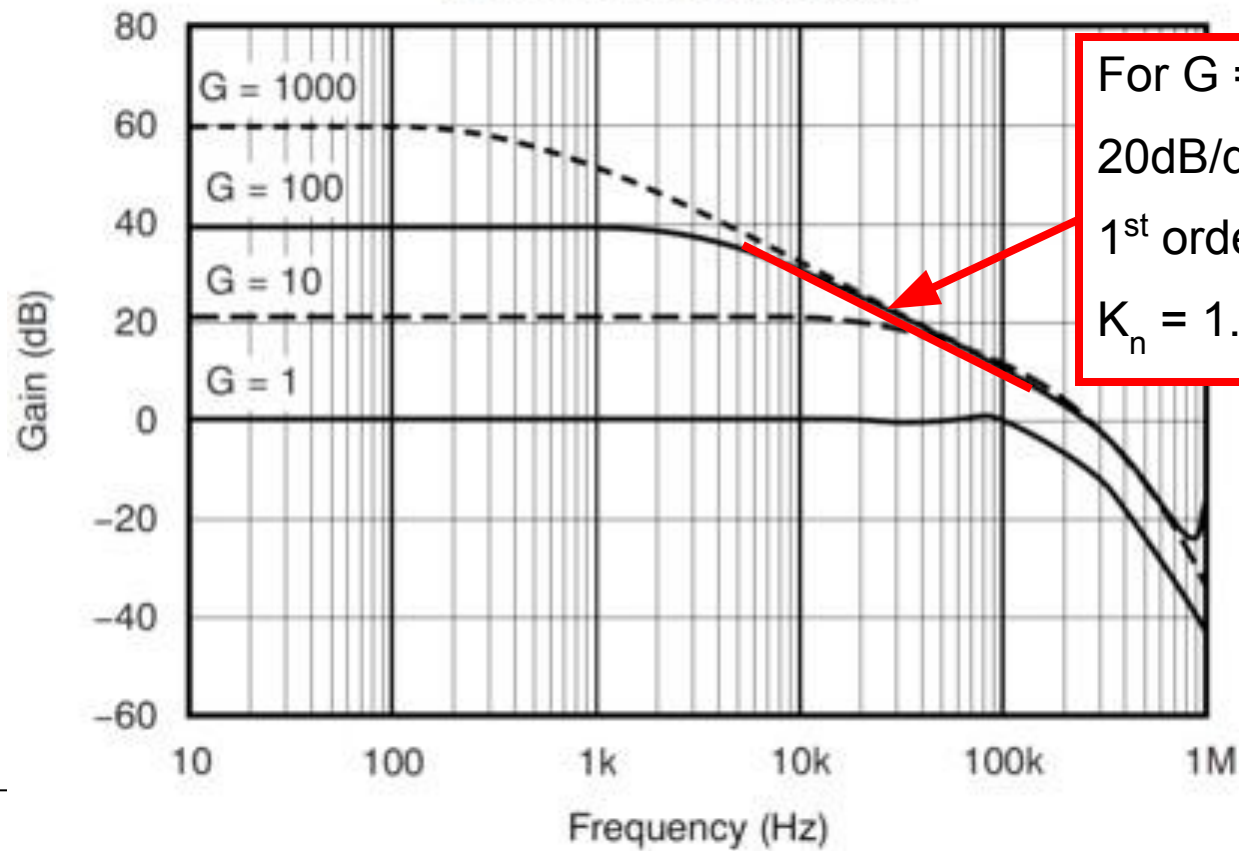

For G = 100  
20dB/decade  
1<sup>st</sup> order  
 $K_n = 1.57$



# Calculate RMS Output Noise for INA333 From Voltage Noise

$$G = 100$$

$$V_{in\_RTI} = 50.85\text{nV}/\text{rtHz} \quad \text{From "Input referred noise" equation}$$

$$f_H = 3.5\text{kHz} \quad \text{From data sheet table for gain} = 100$$

$$K_n = 1.57 \quad \begin{array}{l} \text{For first order function} \\ \text{See Gain vs Frequency in the data sheet} \end{array}$$

$$BW_n = f_H \cdot K_n = 5.495\text{kHz} \quad \text{Noise Bandwidth}$$

$$e_{n\_out} = G \cdot V_{in\_RTI} \sqrt{BW_n} = 376.9\mu\text{V}_{\text{rms}} \quad \text{RMS Output Noise}$$

$$e_{n\_outPP} = 6 \cdot e_{n\_out} = 2.26\text{mV}_{\text{pp}} \quad \text{Peak-to-Peak Output}$$



# Simulation of Ramp WA



# Simulate the Circuit

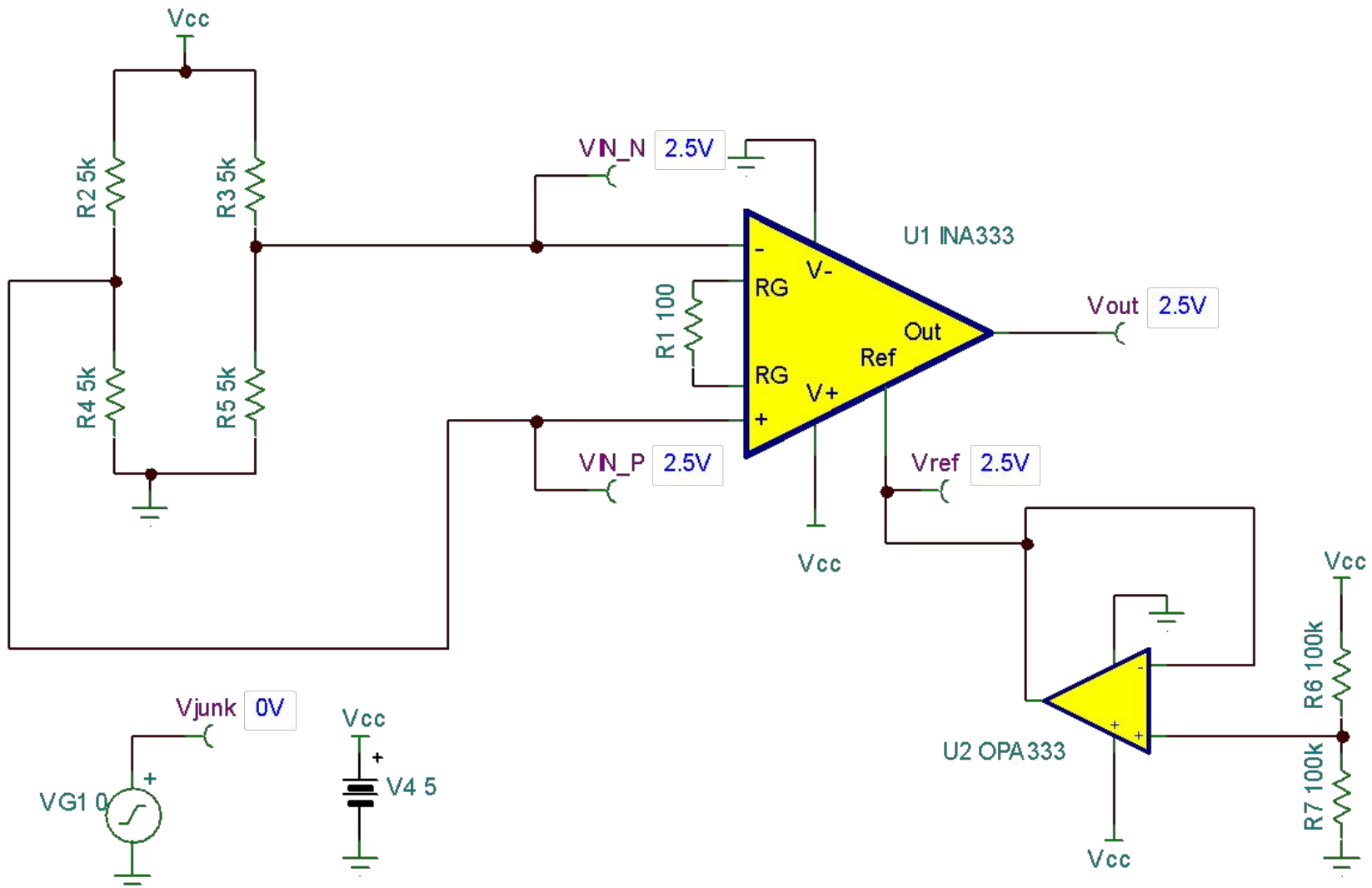



# Using Tina Spice

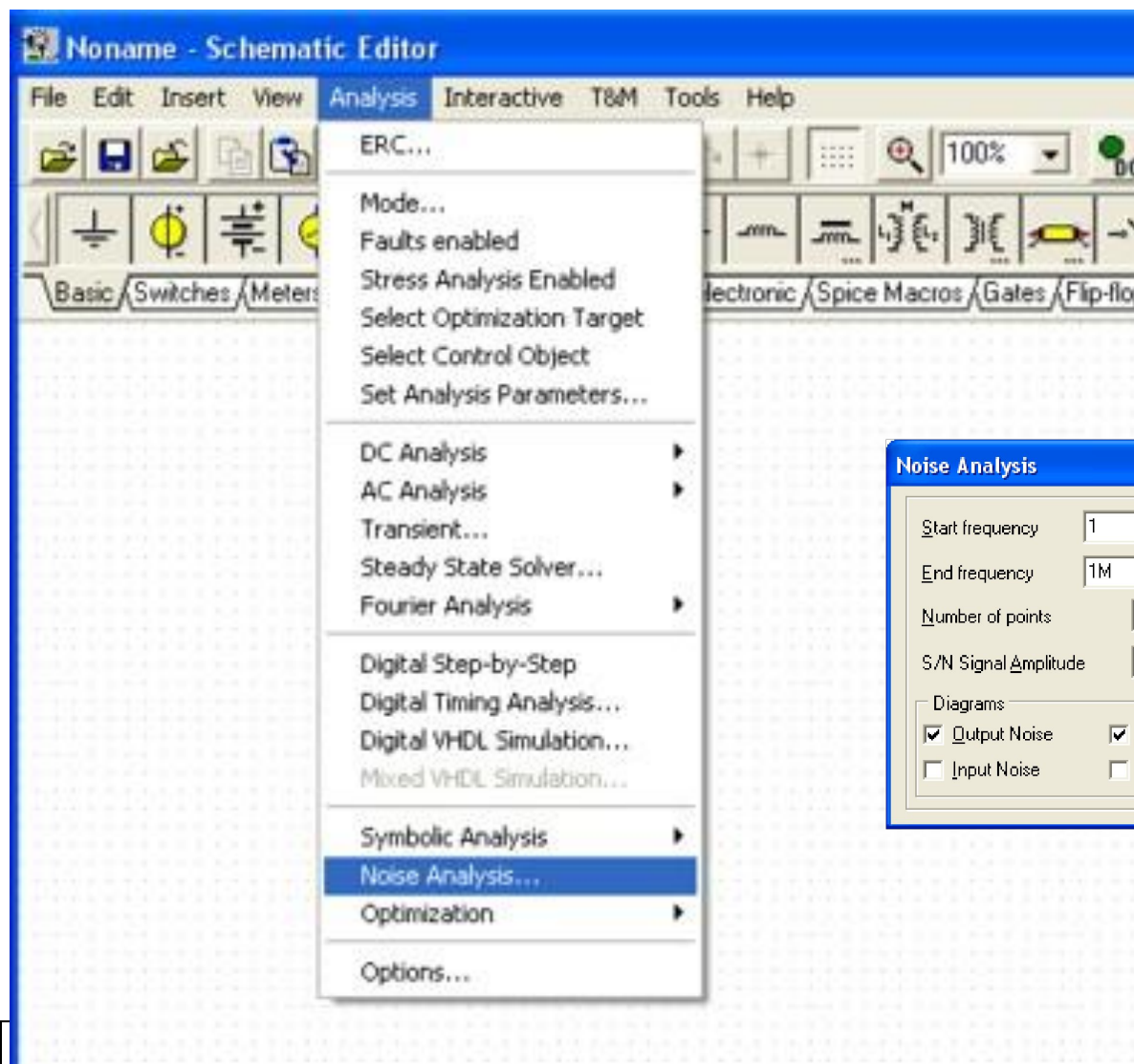



# Noise Spectral Density at the Output

Voltage Spectral Density Out vs. Frequency

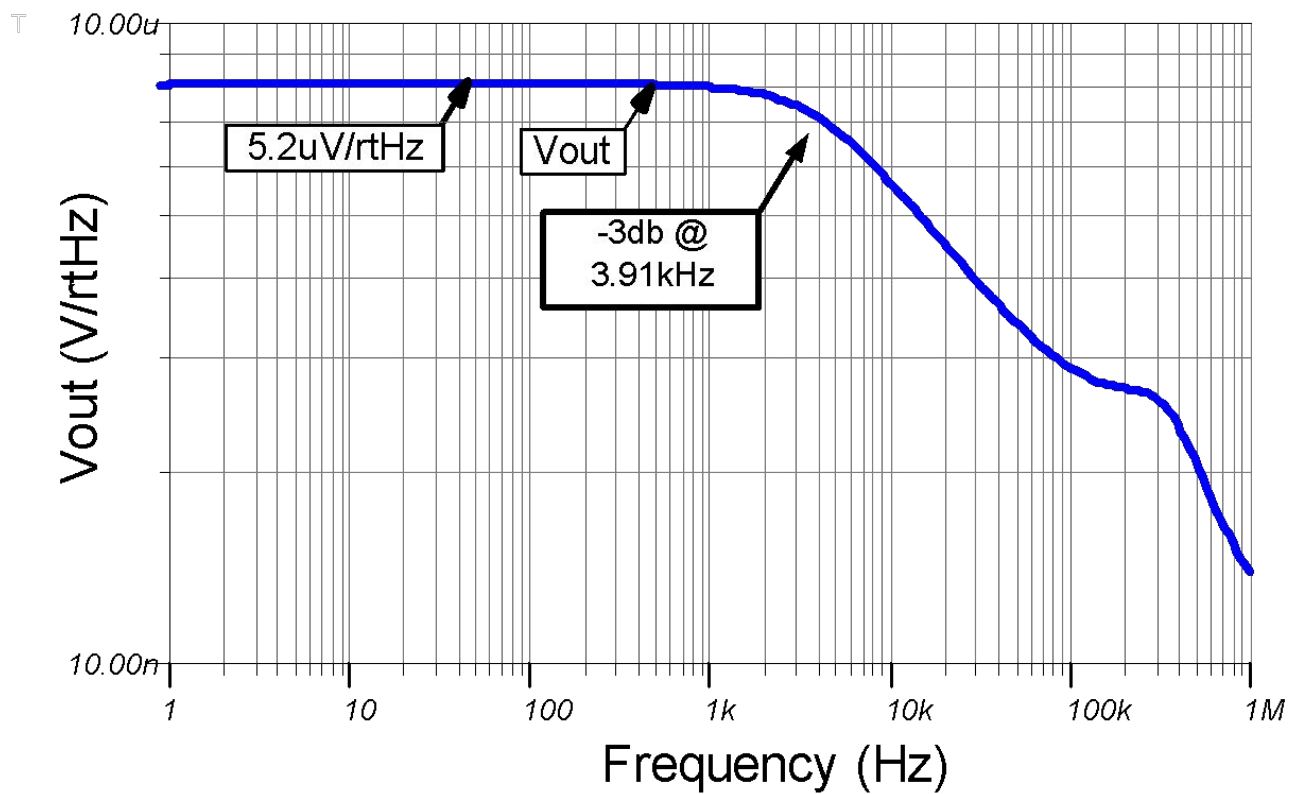



# Total RMS Noise at the Output

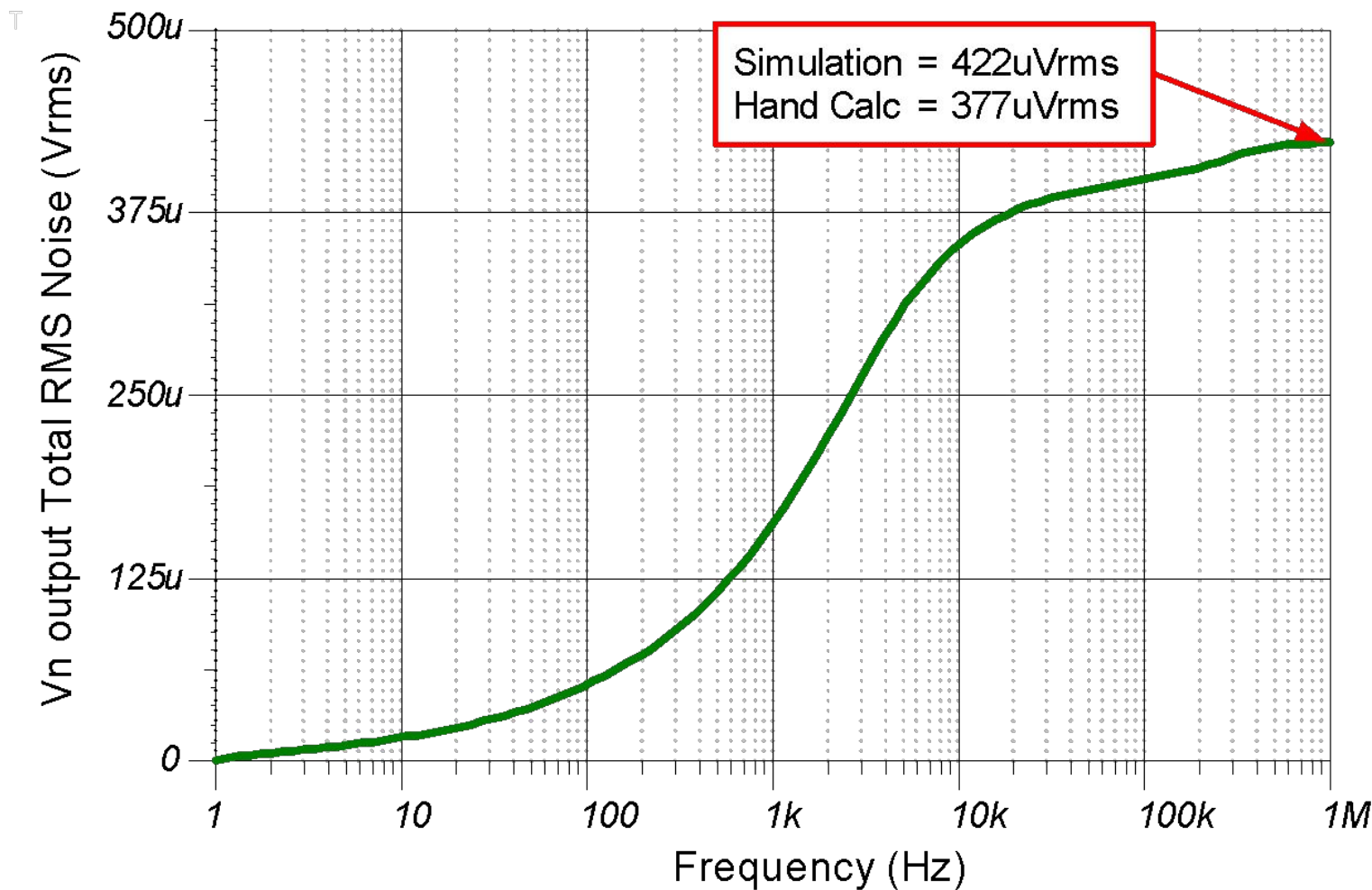



# Why doesn't calculation match simulation exactly?

PARAMETER	INA333			UNIT
	MIN	TYP	MAX	
<b>FREQUENCY RESPONSE</b>				
Bandwidth, -3dB				
G = 1		150		kHz
G = 10		35		kHz
G = 100		3.5		kHz
G = 1000		350		Hz

Bandwidth from Data Sheet and simulated bandwidth is different.

Voltage Spectral Density Out vs. Frequency

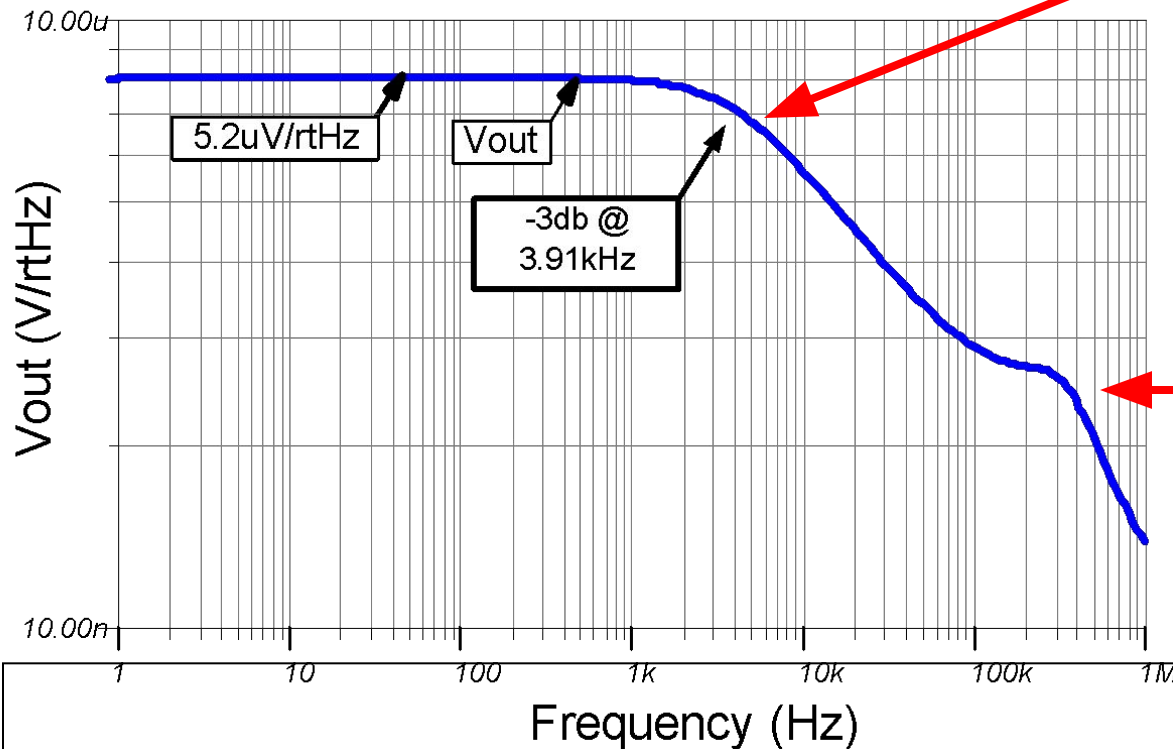

The roll-off was approximated as first order in the calculations. Simulation shows that it is not first order.





REGISTRATION HAS BEGUN



# Averaging Circuit

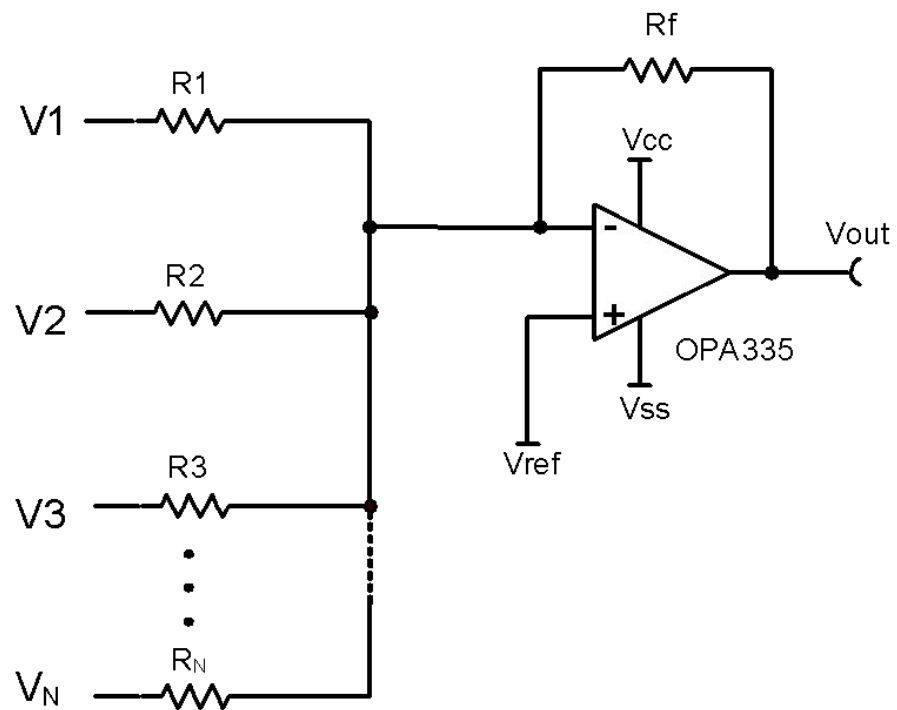

$$V_{\text{out}} = V_{\text{ref}} - R_f \left( \frac{V_1}{R_1} + \frac{V_2}{R_2} + \frac{V_3}{R_3} + \dots + \frac{V_N}{R_N} \right) \quad [15]$$

For an averaging circuit choose

$$R_1 = R_2 = R_3 = \dots R_N = R$$

$$R_f = R / N$$

$$V_{\text{out}} = V_{\text{ref}} - \frac{(V_1 + V_2 + V_3 + \dots + V_N)}{N} \quad [16]$$



# Noise in Averaging Circuit

$$v_{\text{noise\_output}} = \sqrt{\left(\frac{v_{\text{noise1}}}{N}\right)^2 + \left(\frac{v_{\text{noise2}}}{N}\right)^2 + \left(\frac{v_{\text{noise3}}}{N}\right)^2 + \dots + \left(\frac{v_{\text{noiseN}}}{N}\right)^2}$$

Where  $v_{\text{noise1}}$ ,  $v_{\text{noise2}}$ ,  $v_{\text{noise3}}$ , ...  $v_{\text{noiseN}}$  are noise sources

If you assume that  $v_{\text{noise1}}$ ,  $v_{\text{noise2}}$ ,  $v_{\text{noise3}}$ , ...  $v_{\text{noiseN}}$  are equal uncorrelated noise sources, then

$$v_{\text{noise\_output}} = \sqrt{N \left(\frac{v_{\text{noise}}}{N}\right)^2} = \sqrt{\frac{v_{\text{noise}}^2}{N}} = \frac{v_{\text{noise}}}{\sqrt{N}} \quad [17]$$



# Averaging Circuit with INA333

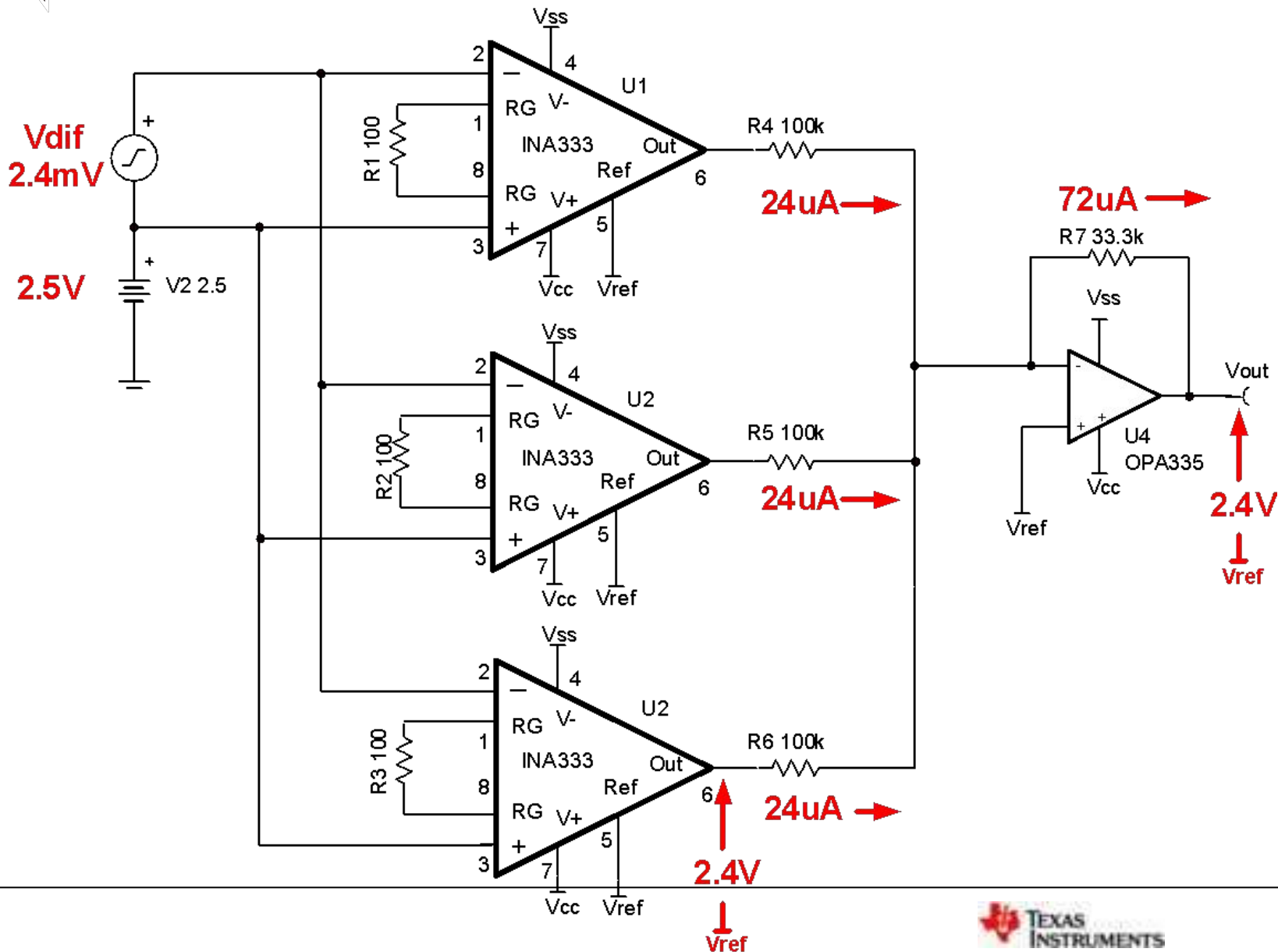



# Experiment with 20 Parallel INA333

**Socketed Gain Set Resistors**

**20 INA333 amps in parallel (jumper selectable)**

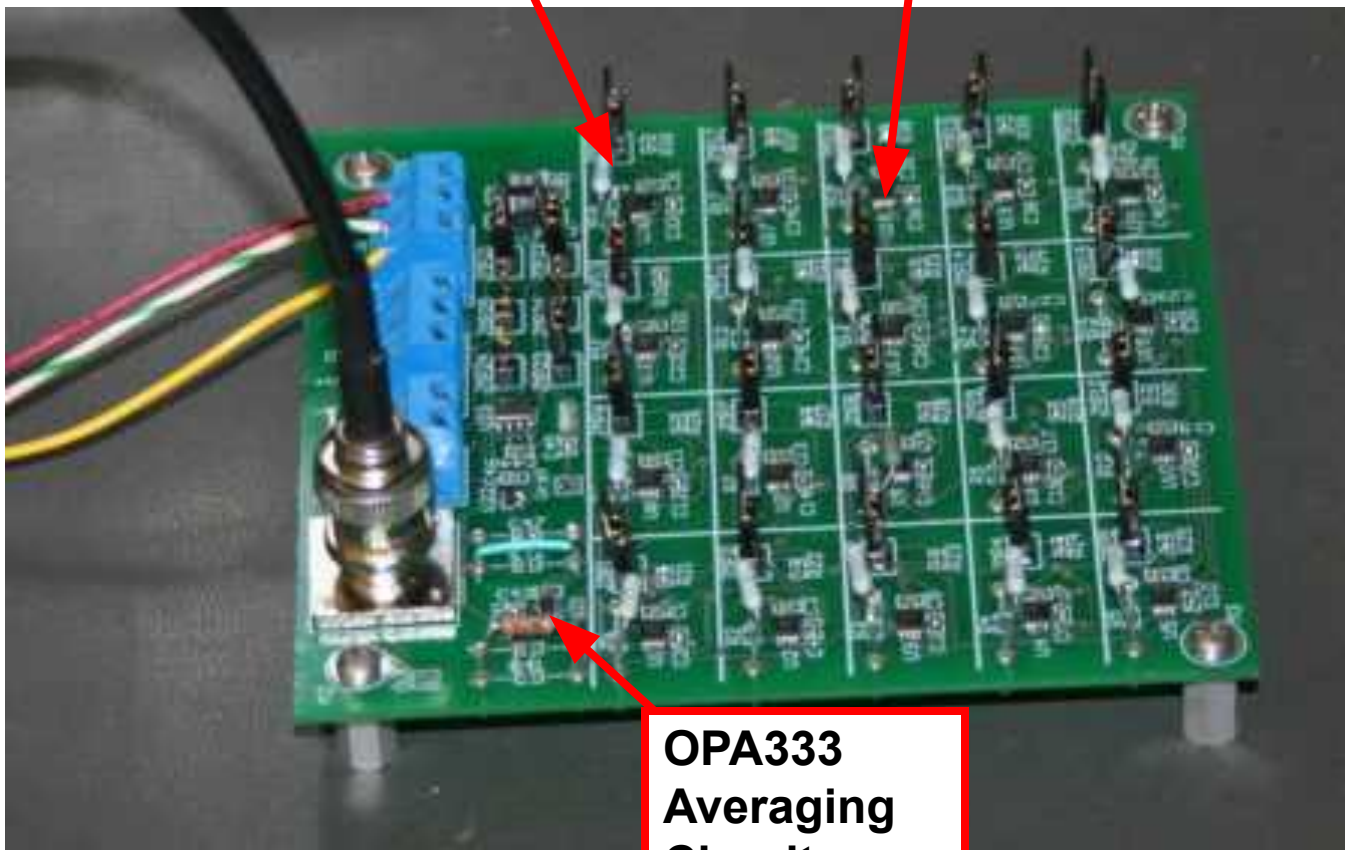

**OPA333 Averaging Circuit**



# Standard Noise Measurement Precautions

**Linear Power  
Source**

**Steel Paint Can  
for Shielding**





# Total Output Noise vs Number of Amplifiers Being Averaged

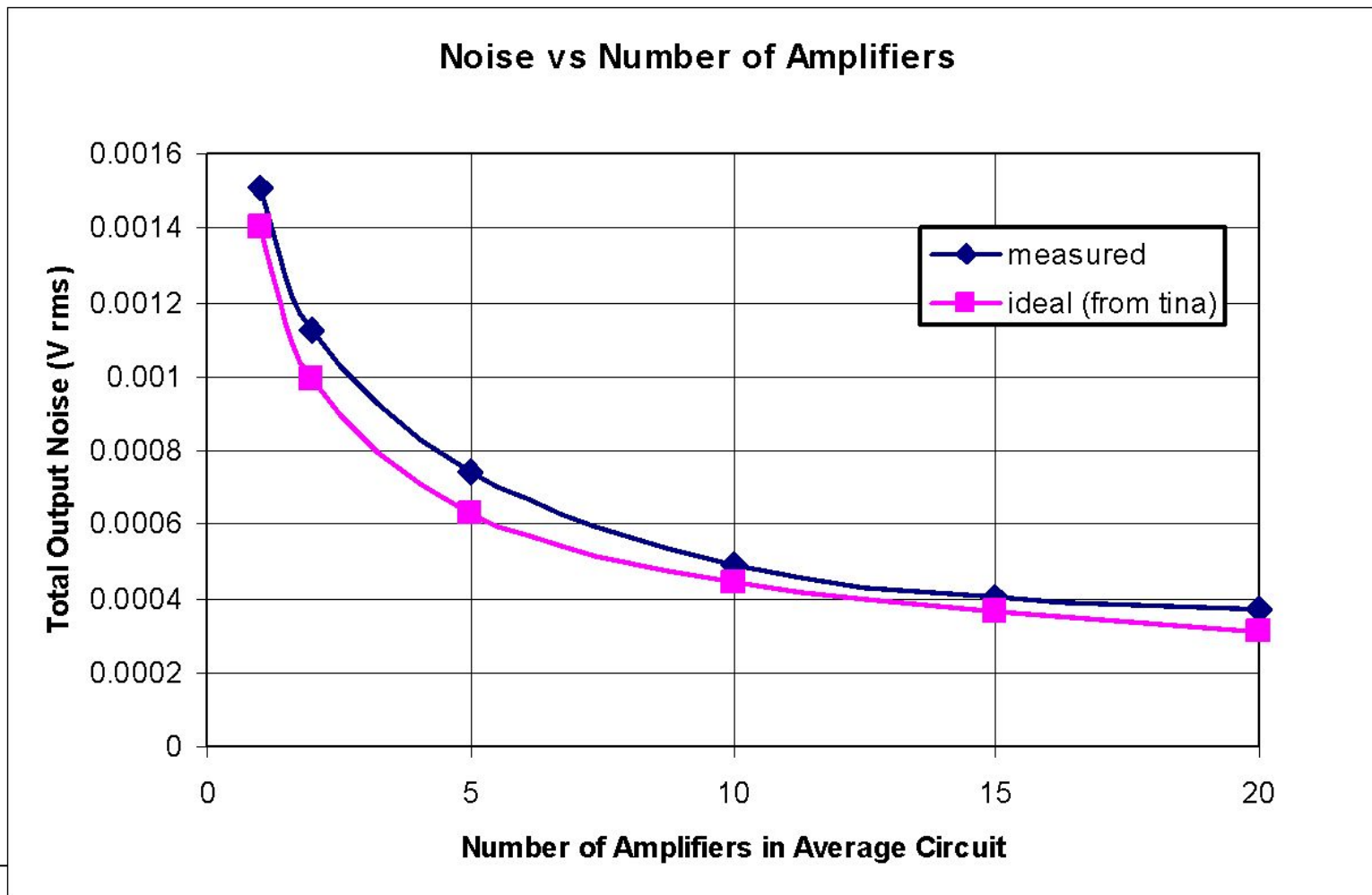



## Measured vs simulated spectral density

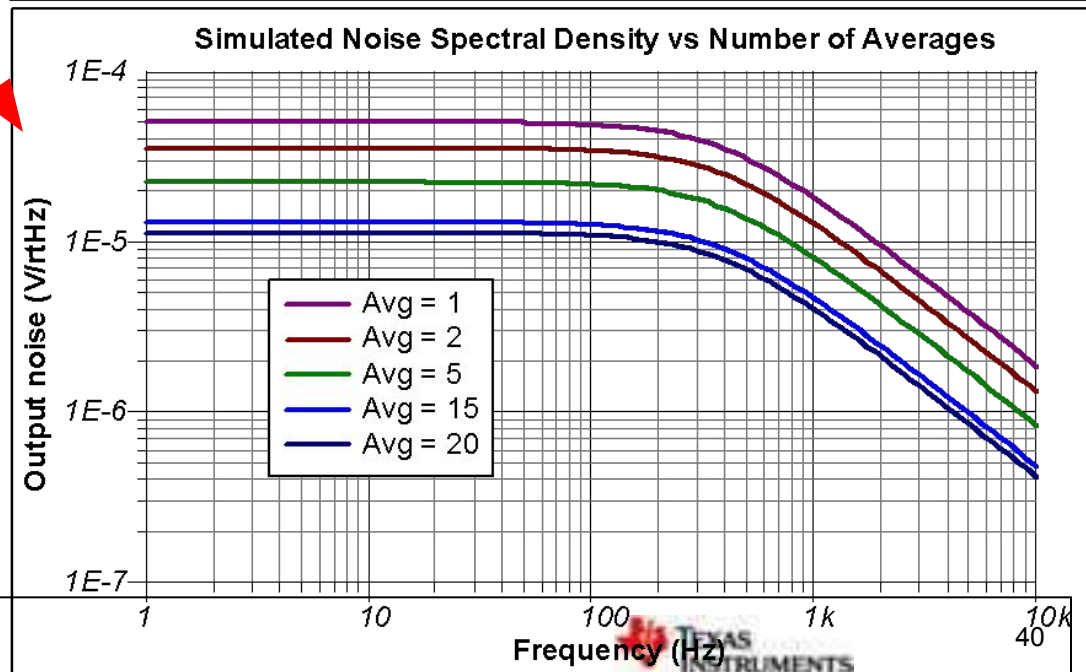
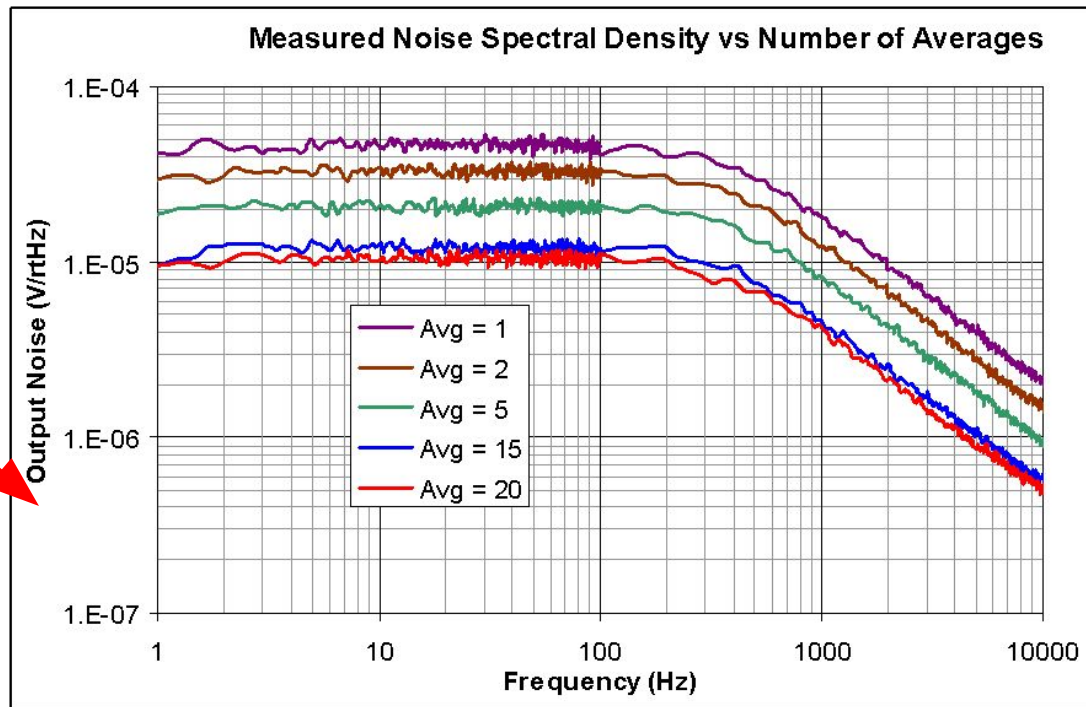





## References

1. [1] Hann, Gina. "Selecting the right op amp - Electronic Products." Electronic Products Magazine – Component and Technology News. 21 Nov. 2008. Web. 09 Dec. 2009.  
<[http://www2.electronicproducts.com/Selecting\\_the\\_right\\_op\\_amp-article-facntexas\\_nov2008-html.aspx](http://www2.electronicproducts.com/Selecting_the_right_op_amp-article-facntexas_nov2008-html.aspx)>.
2. Henry W. Ott, Noise Reduction Techniques in Electronics Systems, John Wiley and Sons

## Acknowledgments:

1. R. Burt, Technique for Computing Noise based on Data Sheet Curves, General Noise Information
2. T. Green, General Information
3. B. Trump, General Information
8. Matt Hann, General INA information and review

## Noise Article Series ([www.en-genius.net](http://www.en-genius.net))

[http://www.en-genius.net/site/zones/audiovideoZONE/technical\\_notes/avt\\_022508](http://www.en-genius.net/site/zones/audiovideoZONE/technical_notes/avt_022508)



***Thank You  
for  
Your Interest  
in  
INA Noise – Calculation and Measurement***