

LINE PROTECTION

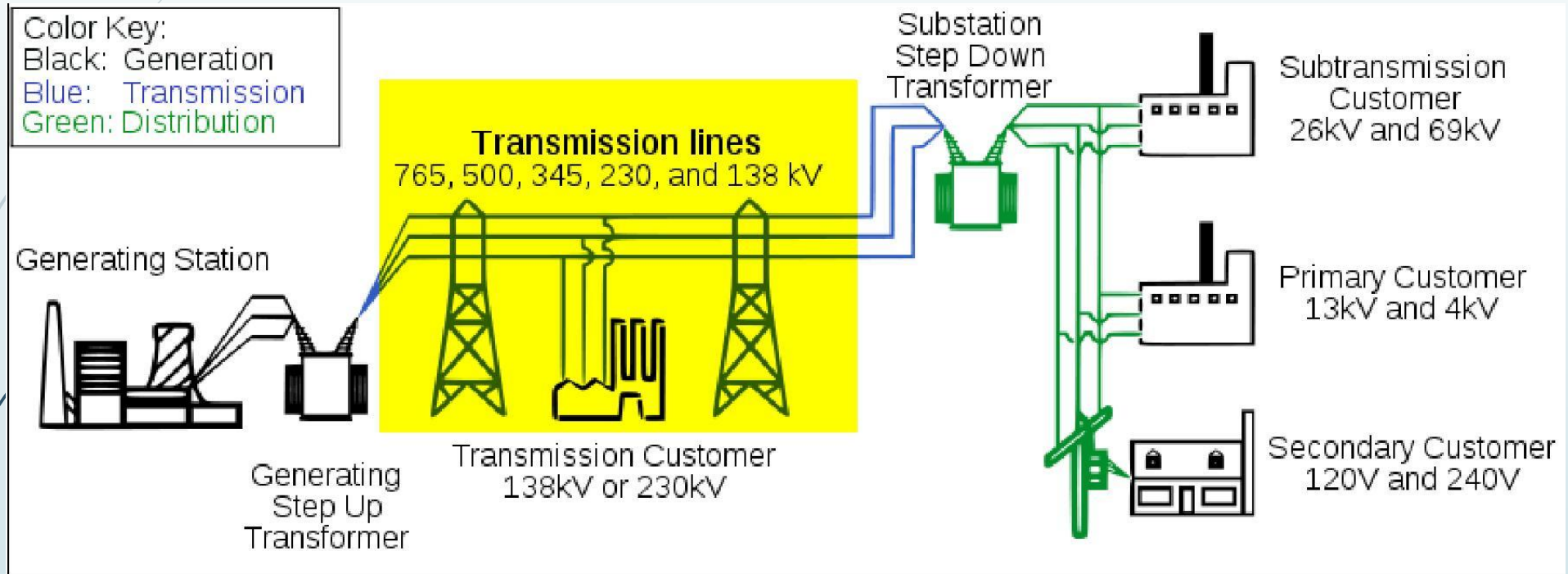



TRANSMISSION LINE PROTECTION

Transmission lines can vary in length from several hundred feet to several hundred miles, and in voltage (line-to-line) from 46KV to 750KV. Construction can be simple, such as a single wood pole with insulators atop a crossarm, with little spacing between the conductors and from the conductors to ground. At the other end of the scale are metal lattice structures with bundled conductors (2 or more conductors per phase) with large spacing between conductors and between conductors and ground.

Faults

- “Faults come uninvited and seldom go away voluntarily.”
- Fault Types:
 - ●Single line-to-ground
 - Line-to-line
 - Three Phase
 - Line-to-line-to-ground



HOW DO WE DO PROTECT Transmission Lines?

- Overcurrent
- Directional overcurrent
- Distance
- Pilot
- Line Current Differential

Assignment of relay protection of power transmission line

- In the event of damage to the insulation of the cable anywhere or extended overhead line voltage is applied to the line creates a leakage current or a short circuit through the broken section.
- The causes insulation failure can be a variety of factors that can exclude himself or to continue their devastating effects. For example, flying between the wires overhead line Stork created a phase to phase fault with their wings and burned, falling nearby.

Опора воздушной ВЛ-110 кВ



For these reasons, all resulting damage to power lines must be immediately eliminated. This is achieved by removing the voltage from the damaged line on the supply side. If such a transmission line is powered from both sides, they both have to turn off the voltage.

Features continuous monitoring of the electrical parameters of the status of all power lines and removing them from the stress from all sides in the event of any emergency situations are assigned to the complex technical systems, which are called by tradition relaying.

The adjective "relay" is derived from the element base on the basis of the electromagnetic relay, the design of which arose with the advent of the first transmission lines and improved to this day.

- To monitor the electrical parameters of power lines need to have bodies of their measurements, which are able to continuously monitor all of the normal mode rejection in the network and at the same time meet the requirements for safe operation.
- The power lines of all voltages, this function is assigned to the measuring transformers. They are divided into transformers:
 - • Current (CURRENT TRANSFORMERS);
 - • voltage (VOLTAGE TRANSFORMERS).
- Since the quality of protection is of paramount importance for the reliability of the electrical system, by measuring current and voltage transformers are increased requirements for accuracy of which are determined by their metrological characteristics.
- Accuracy classes of measuring transformers for use in devices RZA (relay protection and automation) are normalized values of "0.5", "0.2" and "P".

MEASURING TRANSFORMERS

Ввод ВЛ-110 кВ на подстанцию 110/10кВ



VOLTAGE TRANSFORMER

Трансформаторы тока ВЛ-110 кВ на подстанции 110/10кВ



CURRENT TRANSFORMER

Processing the information received organs

- In relaying the main operating element is a switch - electrical device that performs two main functions:
 - • monitors the quality of the controlled parameter, such as current and normally supports stable and does not change the state of its contact system;
 - • If a critical value, called the set point or the minimum threshold, instantly switches the position of the contacts and in this state as long as the monitoring value will not return to normal values.
- The principles of the relay switching schemes of current and voltage in the secondary circuit helps to understand representation of sinusoidal harmonic vector quantities with the image of the complex plane.

Examples of expressions of sinusoidal harmonics of the vector unit circle

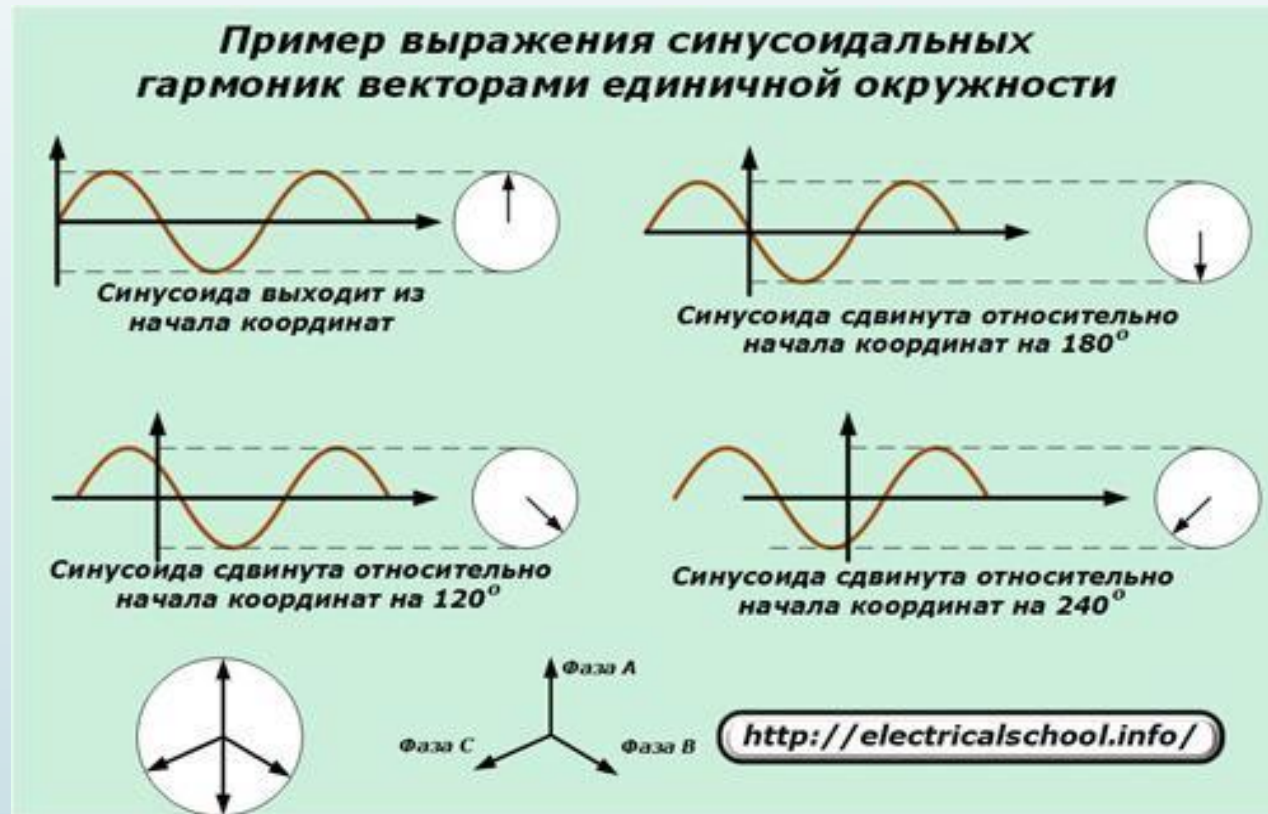

Resistance line control methods

- relay protection devices, estimating the distance to the short circuit has arisen on the basis of measuring the electrical resistance, called spacers or abbreviated DMZ defenses. They are also used in the work circuit current and voltage transformers.
- To measure the resistance of the expression is used Ohm's Law, described for the section of the circuit concerned.
- When passing through the active sinusoidal current, capacitive and inductive impedance vector of the voltage drop across them is deflected in different directions. It takes into account the behavior of relay protection.

BEHAVIOUR current vector and the voltage on various kinds RESISTANCE

According to this principle, many types of resistance relay (RS) working in relay protection and automation devices.

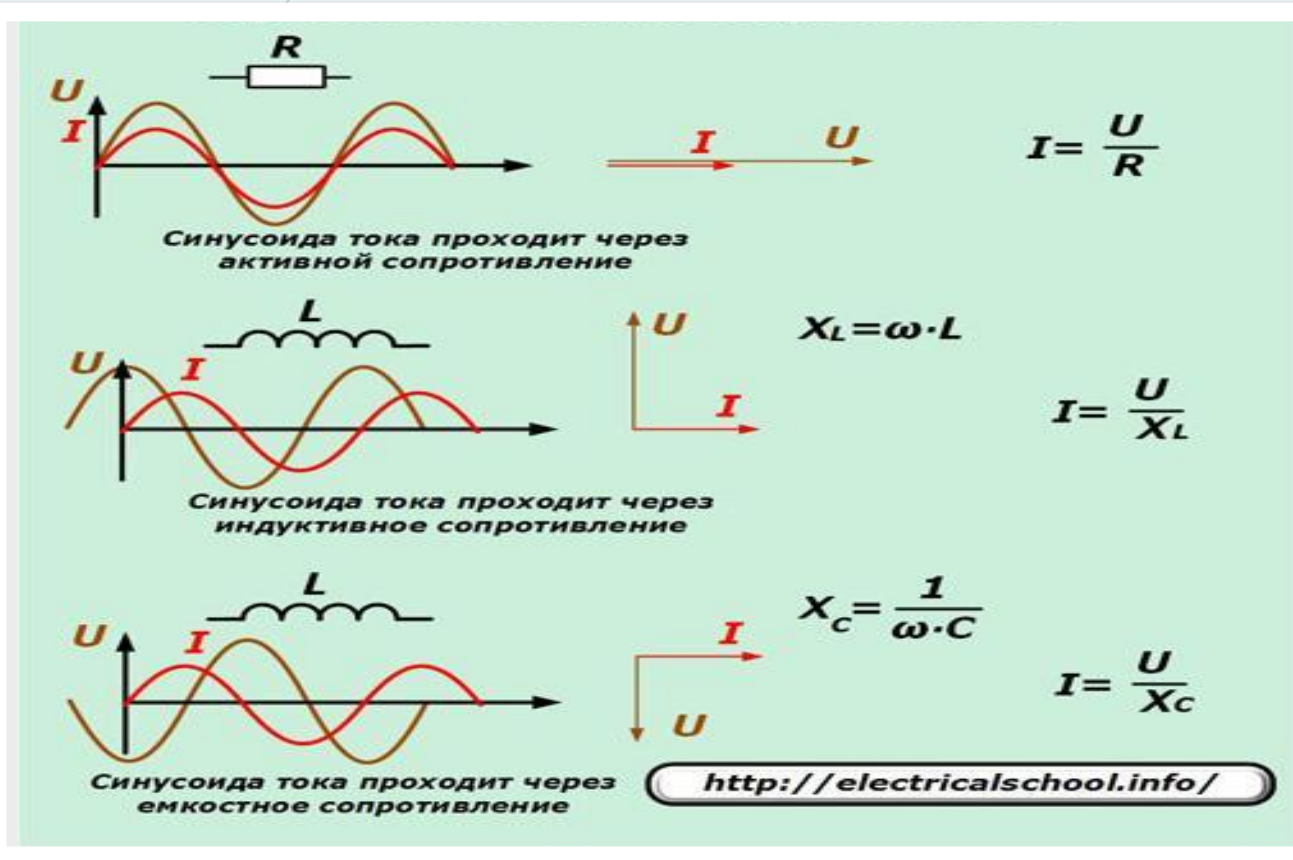

Basic protection of high-voltage lines (differential-phase protection type DFP-201)

- Differential - phase protection type DFP-201 is used as the main protection of overhead transmission lines with voltage of 110 - 220 kV, which is necessary to disable all kinds of damage without delay short-circuit at any point of the protected line.
- The basis of the protection actions laid differential principle or the comparison phase currents at opposite ends of the line. Unlike conventional differential protection, differential protection can protect objects much greater extent (hundreds of kilometers).
- Protection provides information on the current direction of the object to an object at a high frequency (usually) channel, the main element of which is a transmission line. Some transceivers have a modification for communication over fiber - optic lines (FOL), but widespread, they have not yet received, why restrict ourselves to the high-frequency (HF) communication channels and their elements.

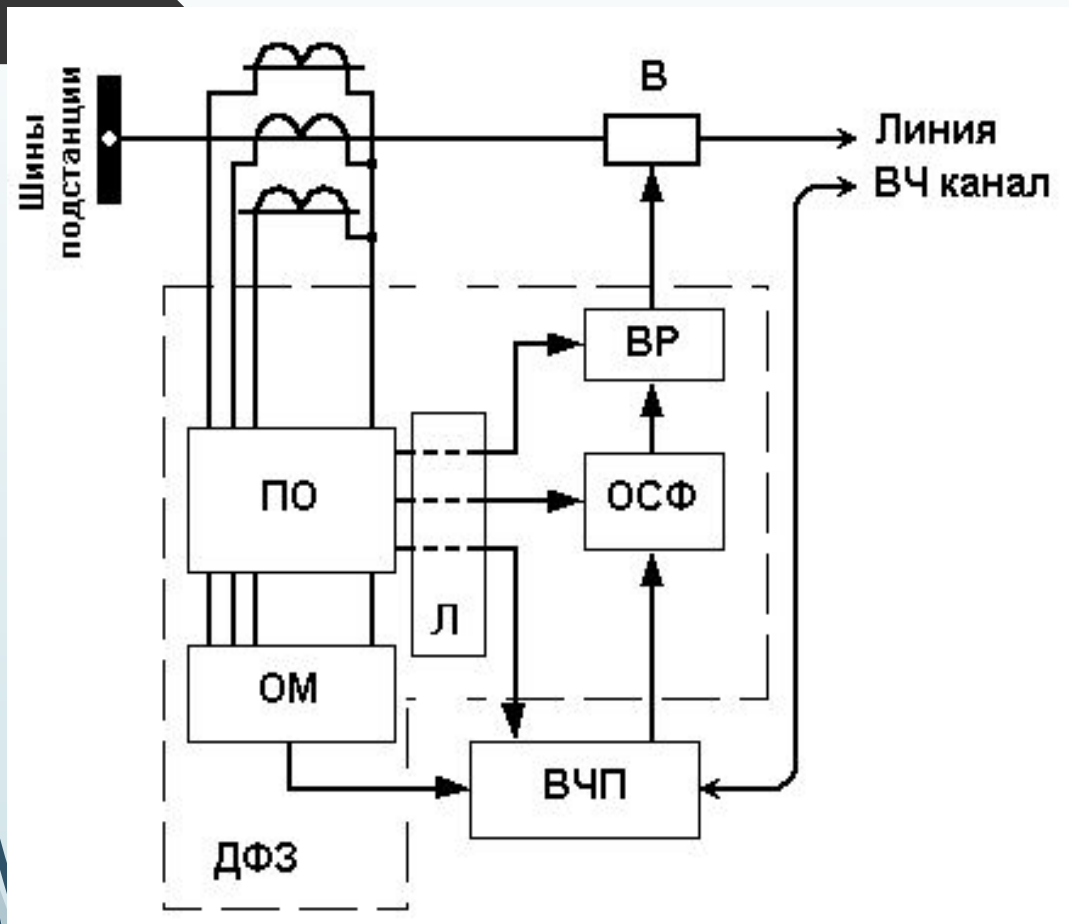

- At fault is DFP zone does not work, so it can not be used for remote backup. DFP is not responding to overload, swing, asynchronous course and unbalance in the system. Protection DFP can be used on lines equipped with per phase reclosure (APA) devices.
- Protection generally consists of two (sometimes three) half-sets. Each of them includes a relay and a high-frequency part. Coverage is limited to protect the current transformers mounted on the ends of the protected line.

- 
- Starting authority starts the transmitter with the appearance of faults in the network environment.
 - The organ manipulation controls the parameters of the RF signal generated by the transmitter.
 - comparing the current phase Authority (CSFs), according to information received from the receiver determines the short circuit: in the protection of coverage area or beyond.
 - The output relay acts on the circuit breaker (B)
 - The logical part of the protection on the information obtained from the starting body, forms a team to start the RF transmitter, the preparation phase comparison authority to act on the trip and prepares relay output circuit.

Diagram illustrating the operation of the protection in case of short circuit in the action zone and outside it, is given below:



The presence of the signal at the transmitter output is determined by the control signals coming from any part of relay protection in the event of abnormal network conditions, or from CDV controls.

When the transmitter does not work (protection is in standby mode) and the receivers do not accept, at the output of receivers takes a direct current a certain value (10 mA or 20 mA), called the current peace. When this electromotive force in a secondary winding of the transformer body phase comparison is not induced, as the magnetic flux is not changed in its core. The current in the phase comparison relays body (WP4-2) is zero.

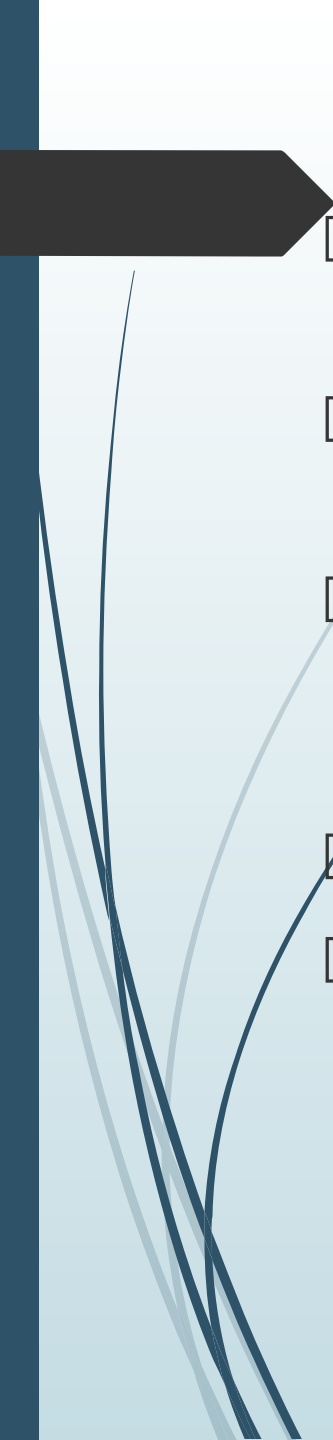
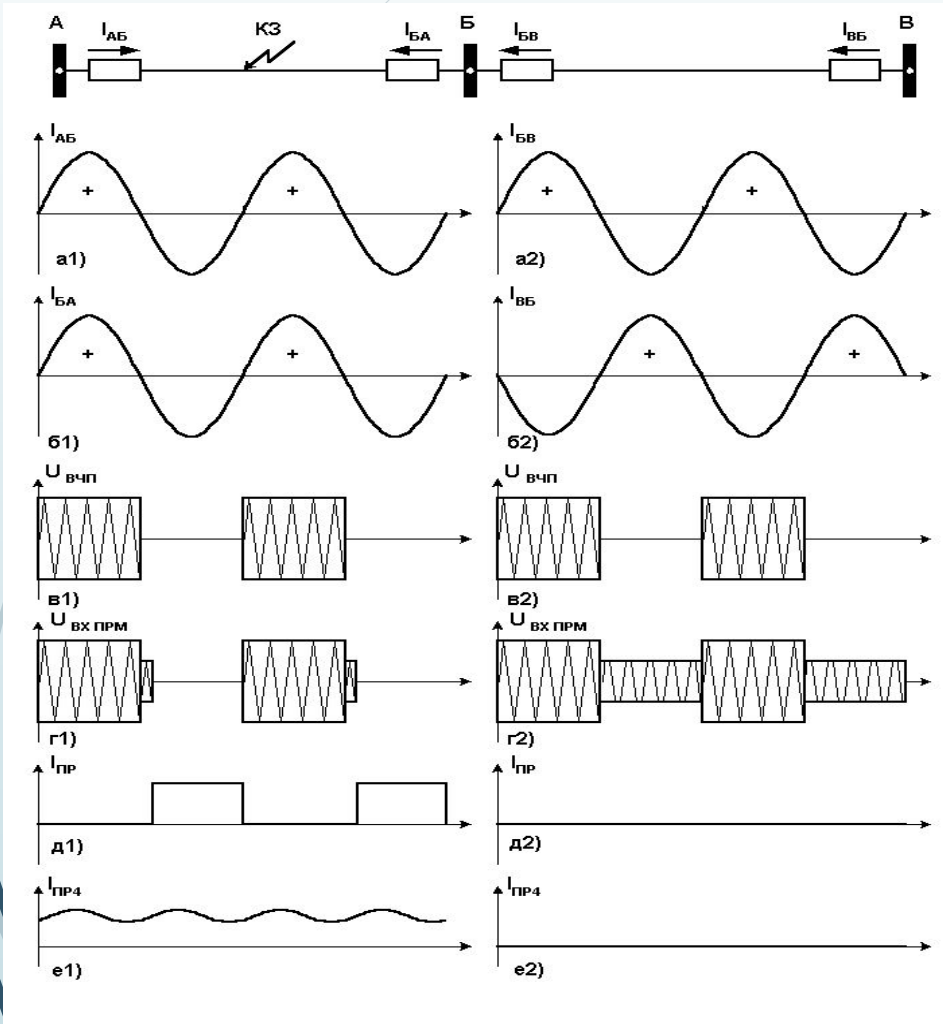
If a short circuit in the protection range (to protect the line A - B) positive half cycle $I_1 + kI_2$ conditional current half-sets AB (substation A line in the direction of the substation B) and BA coincide (Figures A1 and B1). Positive (or negative depending on the type of HF post) half-cycle current corresponds to the emergence of high-frequency pulse output UVCHP RF transmitter (c1). Pulses on U_i Rx receiver input from its own transmitter and received from the opposite end of the line are the same or close to the phase (G1). In the absence of receiver I_{lim} equal to 20 mA current output signal (in some cases - 10 mA), and falls to zero (e1) when a signal. Intermittent reception current through phase comparison transformer body is converted into a pulsating current in the relay coil 2-WP4 (IPR4 e1 diagram).

- When faults outside the protection coverage (protection line B - B) positive half cycle of the current conditional shifted by about 180° (a2, b2). The pulses at the receiver from its own transmitter and received at the opposite end of the line are in antiphase (r2). Receiving current and the coil current is zero 2-4PR (d2, e2).



References

- <http://dororz.ru/>
- <http://electricalschool.info/relay/1647-kak-ustroena-relejjn-aja-zashhita-linijj.html>