

LCD TV

LB350-650

TRAINING MANUAL







Inside of New Models



CONTENTS

- I. Introduction
- II. Inside of Models
- III. Board description
- IV. Disassembly
- V. Trouble Shooting
- VI. Software Relating
- VII. Appendix

Introduction

-  Best Picture Quality
-  Simple Function, New Design
-  Acceptable Price
-  Support HDMI
-  New Functions

II. Inside of New Model

ITEMS	MODELS			
	FHD 32"/37"/40"/46"	HD 26"/32"	HD 19"/22"	HD B350 26"/32"
Panel Resolution	1920*1080	1366*768	1366*768	1366*768
A/V	1 Scart in back, 1 AV in Side	1 Scart in back, 1 AV in Side	1 Scart & 1 AV in back	1 Scart & 1 Common AV with component in Back
S-Video	X			
component	1 component in back 480i/p,/576i/p,720p,1080i			
PC	1 Dsub in back			
HDMI	2 HDMI in back, 1 Side HDMI	2 HDMI in back, 1 Side HDMI	1 HDMI in back	2 HDMI in back
Tuner	1 RF DTV tuner DVB-T/C			DVB-T only
Sound Output	10W	5W/10W	3W	5W
PIP	X			
Sound option	Dolby Digital Plus SRS			
DNIe	X			
PCB SIZE	192*195	192*195	192*158	192*122
Headphone	X	X	O	X
Remocon	TM950	TM940		
Anynet+	O	X		

Remote Controller Type

TM940

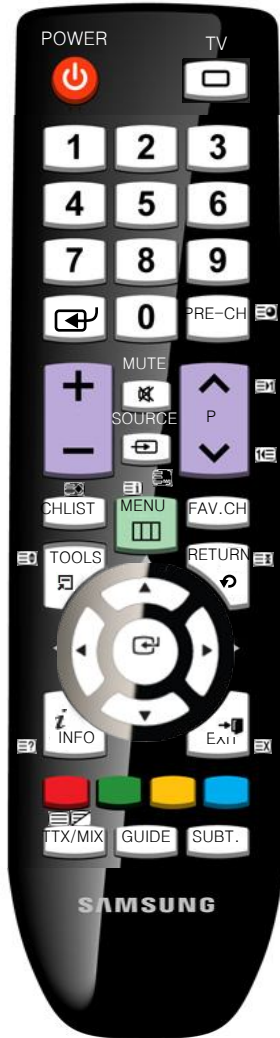

TM950



TOOLS [RF]

Picture Size
Picture Mode
Sound Mode
Sleep Timer
SRS TruSurround HD
Energy Saving
Dual I-II
Add to Favorite

TOOLS [HDMI, AV, Scart, Component]

Picture Size
Picture Mode
Sound Mode
Sleep Timer
SRS TruSurround HD
Energy Saving

TOOLS [PC]

Picture Size
Picture Mode
Sound Mode
Sleep Timer
SRS TruSurround HD
Energy Saving
Auto Adjustment

TOOLS [PC]

Picture Mode
Sound Mode
Sleep Timer
Energy Saving
Auto Adjustment

TOOLS [HDMI, AV, Scart, Component]

Picture Mode
Sound Mode
Sleep Timer
Energy Saving

TOOLS [RF]

Picture Mode
Sound Mode
Sleep Timer
Energy Saving
Add to Favorite

B350 : HD 26"/32"

CABINET

- C/Front : New Design, High Glossy
- C/Rear : Decoration, Holder-Boss, Guide-Stand all New

User Key Pad : Touch Type



B450

HD 19", 22", 26", 32"



B460

HD, 32"



CABINET

- C/Front : PDP B450 Design
- C/Rear , Decoration, Holder-Boss, Guide-Stand all New

Stand Type : Rectangular Glass Type

User Key Pad : Touch Type

B530

FHD 32", 37", 40", 46"



CABINET

- C/Front : A550 P3
- C/Rear, New Decoration,
Holder-Boss, Guide-Stand

Stand : Rectangular Mold-Stand

B650

HD: 19"/22"

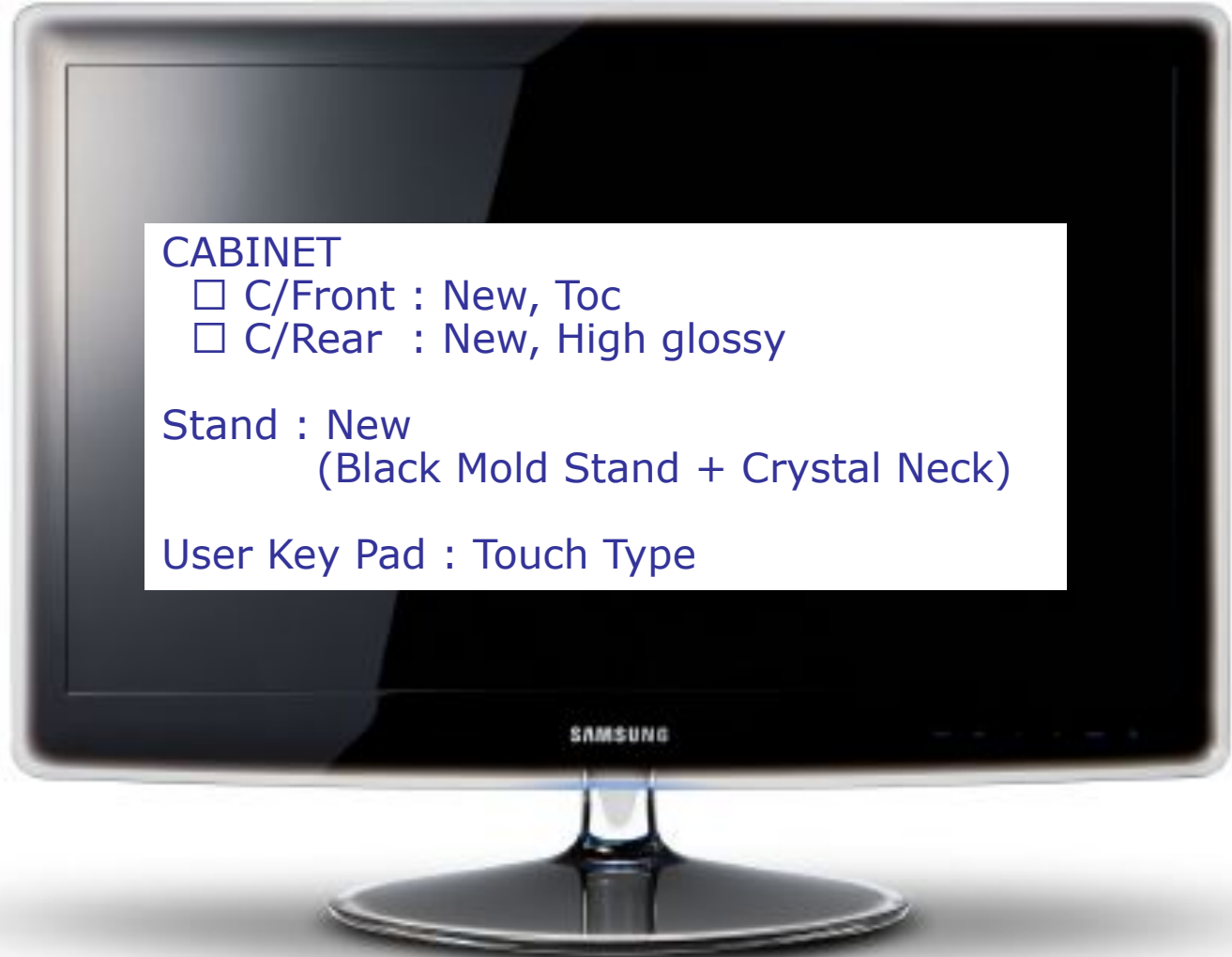

Control & Connection Panel

Viewing the Control Panel

- ☑ The product colour and shape may vary depending on the model.
- ☑ You can use a button by pressing the side panel buttons.

❶ SOURCE



Toggles between all the available input sources. In the on-screen menu, use this button as you would use the **ENTER**  button on the remote control.

❷ MENU



Press to see an on-screen menu of your TV's features.

❸ - +

Press to increase or decrease the volume.

In the on-screen menu, use the -  + buttons as you would use the  and  buttons on the remote control.

❹ < CH >

Press to change channels. In the on-screen menu, use the < CH > buttons as you would use the  and  buttons on the remote control.

❺ POWER INDICATOR

Blinks and turns off when the power is on and lights up in stand-by mode.

❻ (POWER)

Press to turn the TV on and off.

❼ REMOTE CONTROL SENSOR

Aim the remote control towards this spot on the TV.

❽ SPEAKERS

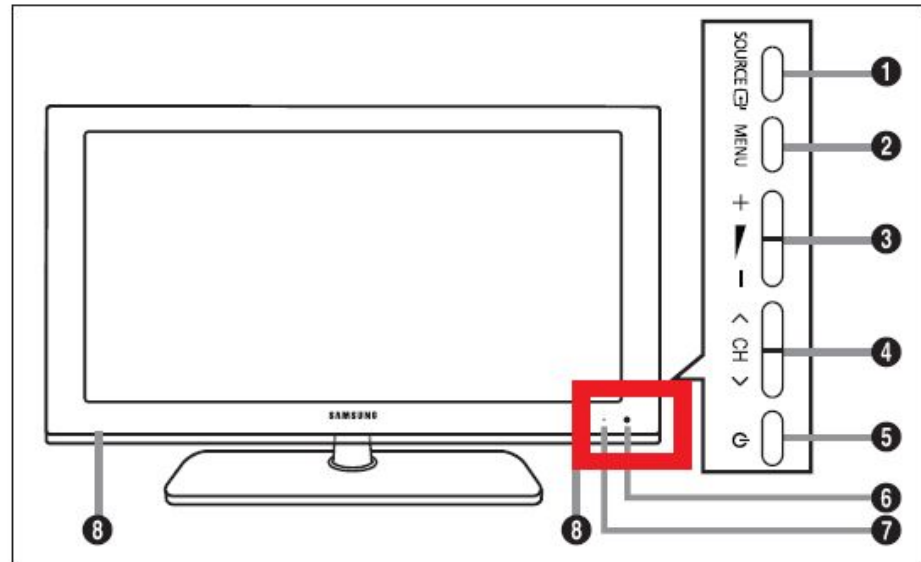

New Model

II. Inside of New Model

Viewing the Control Panel

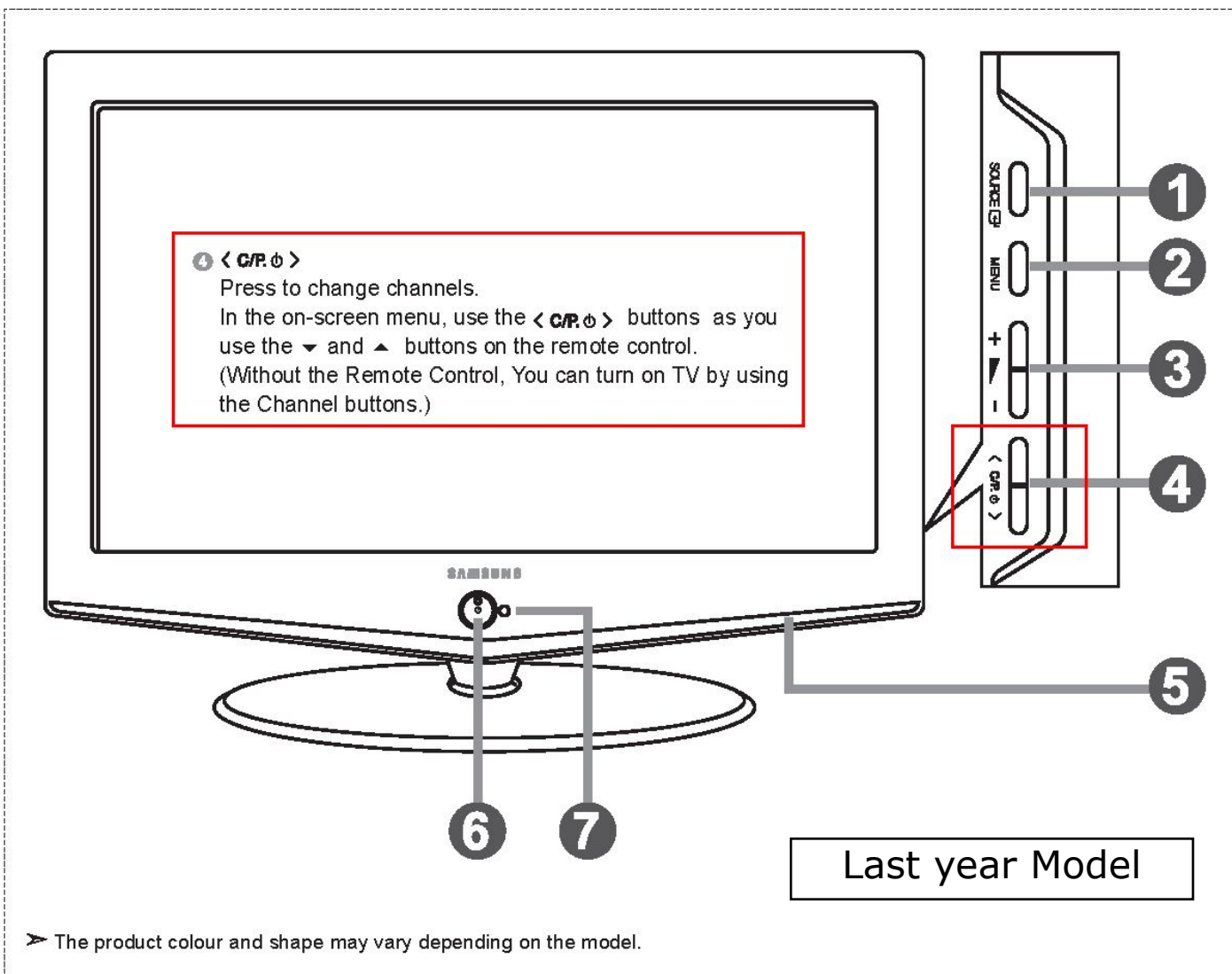

Control & Connection Panel

Viewing the Connection Panel

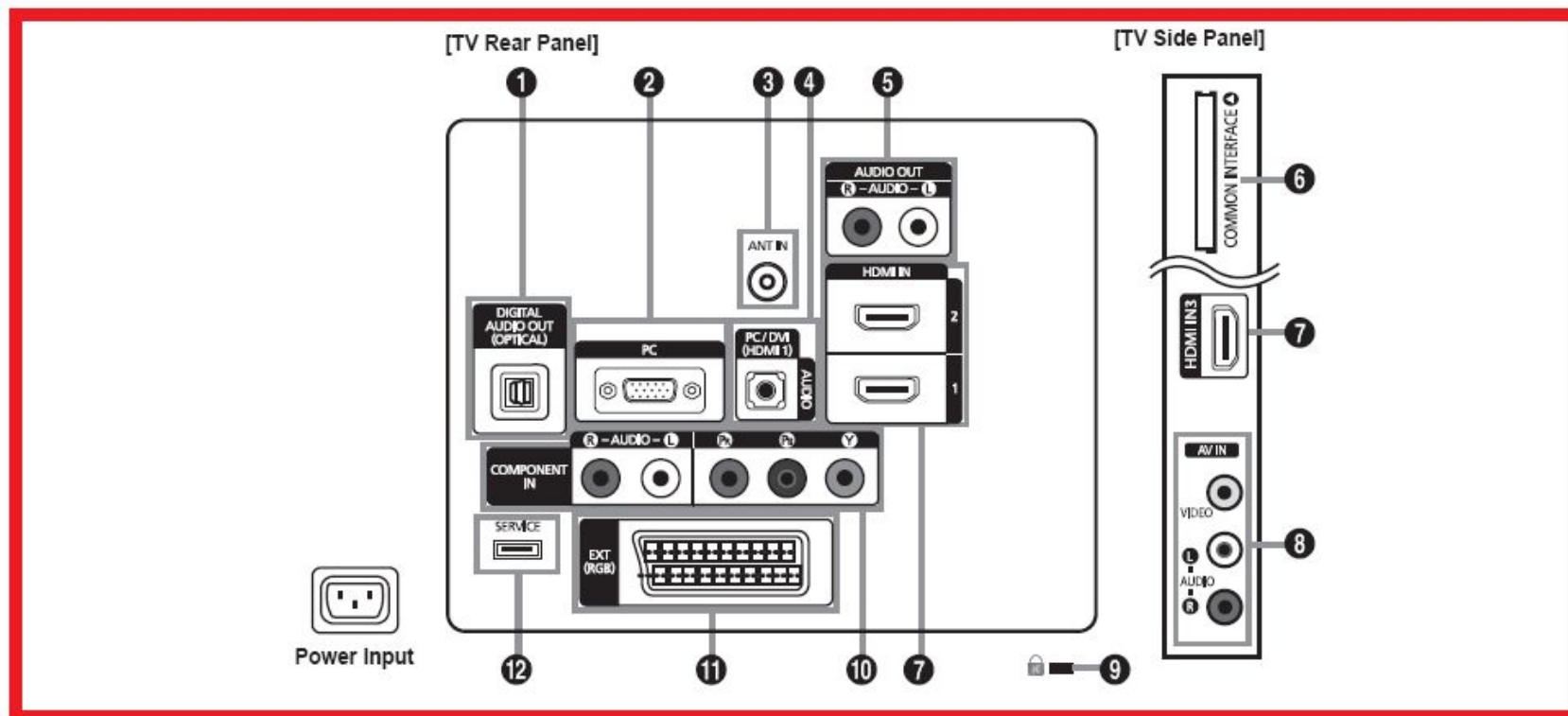

- ☑ The product colour and shape may vary depending on the model.
- ☑ Whenever you connect an external device to your TV, make sure that power on the unit is turned off.
- ☑ When connecting an external device, match the colour of the connection terminal to the cable.

Control & Connection Panel

❶ DIGITAL AUDIO OUT (OPTICAL)

- Connect to a Digital Audio Component.
- ☑ When the HDMI IN jacks are connected, the **DIGITAL AUDIO OUT (OPTICAL)** jack on the TV outputs 2 channel audio only. If you want to hear 5.1 channel audio, connect the Optical jack on the DVD player or Cable / Satellite Box directly to an Amplifier or Home Theater, not the TV.

❷ PC

- Connect to the video output jack on your PC.

❸ PC/DVI(HDMI 1)[AUDIO]

- Connect to the audio output jack on your PC.
- DVI audio outputs for external devices.

❹ ANT IN

To view television channels correctly, a signal must be received by the set from one of the following sources: An outdoor aerial / A cable television network

❺ AUDIO OUT [R-AUDIO-L]

- Connect RCA audio cables to **AUDIO OUT [R-AUDIO-L]** on the rear of your set and the other ends to corresponding audio in connectors on the Amplifier or DVD Home Theatre.

❻ COMMON INTERFACE Slot

- When not inserting 'CI CARD' in some channels, 'Scrambled Signal' is displayed on the screen.
- The pairing information containing a telephone number, CI CARD ID, Host ID and other information will be displayed in about 2~3 minutes. If an error message is displayed, please contact your service provider.
- When the channel information configuration has finished, the message "Updating Completed" is displayed, indicating that the channel list is now updated.
- ☑ You must obtain a CI CARD from a local cable service provider. Remove the CI CARD by carefully pulling it out with your hands since dropping the CI CARD may cause damage to it.
- ☑ Insert the CI-Card in the direction marked on it.
- ☑ The place of the **COMMON INTERFACE** Slot may be different depending on its model.
- ☑ CAM is not supported in some countries and regions, check with your authorized dealer.

Control & Connection Panel

7 HDMI IN 1, HDMI IN 2, HDMI IN 3

- Connects to the HDMI jack of a device with an HDMI output.
- ☑ No sound connection is needed for an HDMI to HDMI connection.
- ☑ Use the **HDMI IN 1** jack for DVI connection to an external device. Use a DVI to HDMI cable or DVI-HDMI adapter (DVI to HDMI) for video connection and the **DVI IN (HDMI1) [R-AUDIO-L]** jacks for audio.

- ☑ What is HDMI?
 'High Definition Multimedia interface' allows the transmission of high definition digital video data and multiple channels of digital audio. The HDMI / DVI terminal supports DVI connection to an extended device with the appropriate cable (not supplied). The difference between HDMI and DVI is that the HDMI device is smaller in size, has the HDCP (High Bandwidth Digital Copy Protection) coding feature installed, and supports multi - channel digital audio.
- ☑ The TV may not output sound and pictures may be displayed with abnormal colour when DVD players / Cable Boxes / Satellite receivers supporting HDMI versions older than 1.3 are connected. When connecting an older HDMI cable and there is no sound, connect the HDMI cable to the **HDMI IN 1** jack and the audio cables to the **PC/DVI(HDMI 1)[AUDIO]** jacks on the back of the TV. If this happens, contact the company that provided the DVD player / Cable Box / Satellite receiver to confirm the HDMI version, then request a firmware update. HDMI cables that are not 1.3 may cause annoying flicker or no screen display.

8 AV IN [VIDEO], [R-AUDIO-L]

- Connect RCA cable to an appropriate external A/V device such as VCR, DVD or Camcorder.
- Connect RCA audio cables to **[R-AUDIO-L]** on your set and the other ends to corresponding audio out connectors on the A/V device.

9 KENSINGTON LOCK (depending on the model)

- The Kensington Lock (optional) is a device used to physically fix the system when used in a public place.
- If you want to use a locking device, contact the dealer where you purchased the TV.
- The location of the Kensington Lock may be different depending on its model.

10 COMPONENT IN

- Connect component video cables (optional) to component connector (Pr, Pa, Y) on the rear of your set and the other ends to corresponding component video out connectors on the DTV or DVD.
- If you wish to connect both the Set-Top Box and DTV (or DVD), you should connect the Set-Top Box to the DTV (or DVD) and connect the DTV (or DVD) to component connector (Pr, Pa, Y) on your set.
- The Pr, Pa and Y connectors on your component devices (DTV or DVD) are sometimes labeled Y, B-Y and R-Y or Y, Cb and Cr.
- Connect RCA audio cables (optional) to **[R-AUDIO-L]** on the rear of your set and the other ends to corresponding audio out connectors on the DTV or DVD.

11 EXT

Connector	Input			Output
	Video	Audio (L / R)	RGB	Video + Audio (L / R)
EXT	O	O	O	Only TV or DTV output is available.

- Inputs or outputs for external devices, such as VCR, DVD, video game device or video disc players.

12 SERVICE

- Connector for software upgrades.

II. Inside of New Model

SYSTEM CONTROL OVERVIEW

Block Diagram

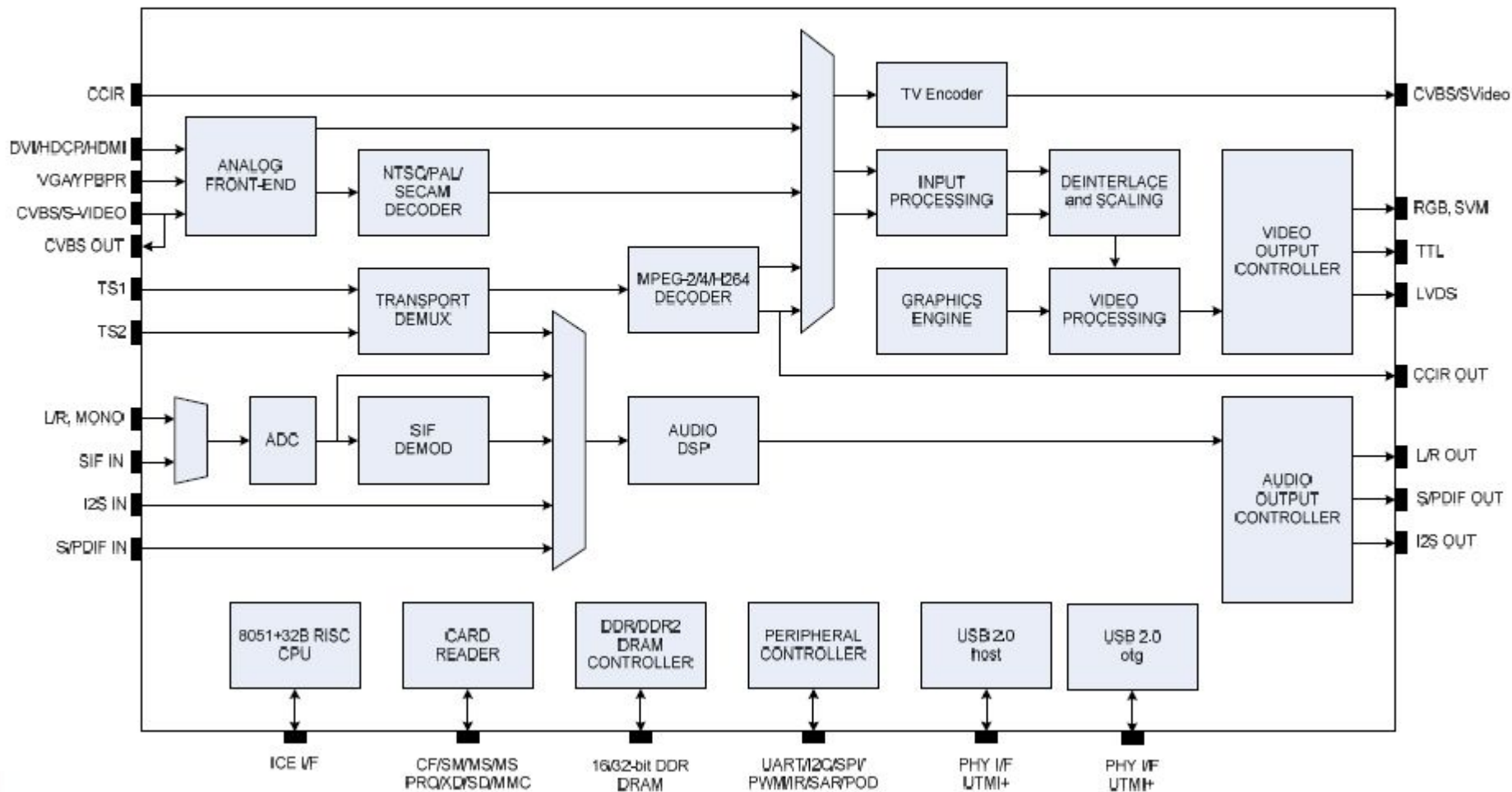

II. Inside of Models 26"/32"/37"/40"/46" Europe

Block Diagram

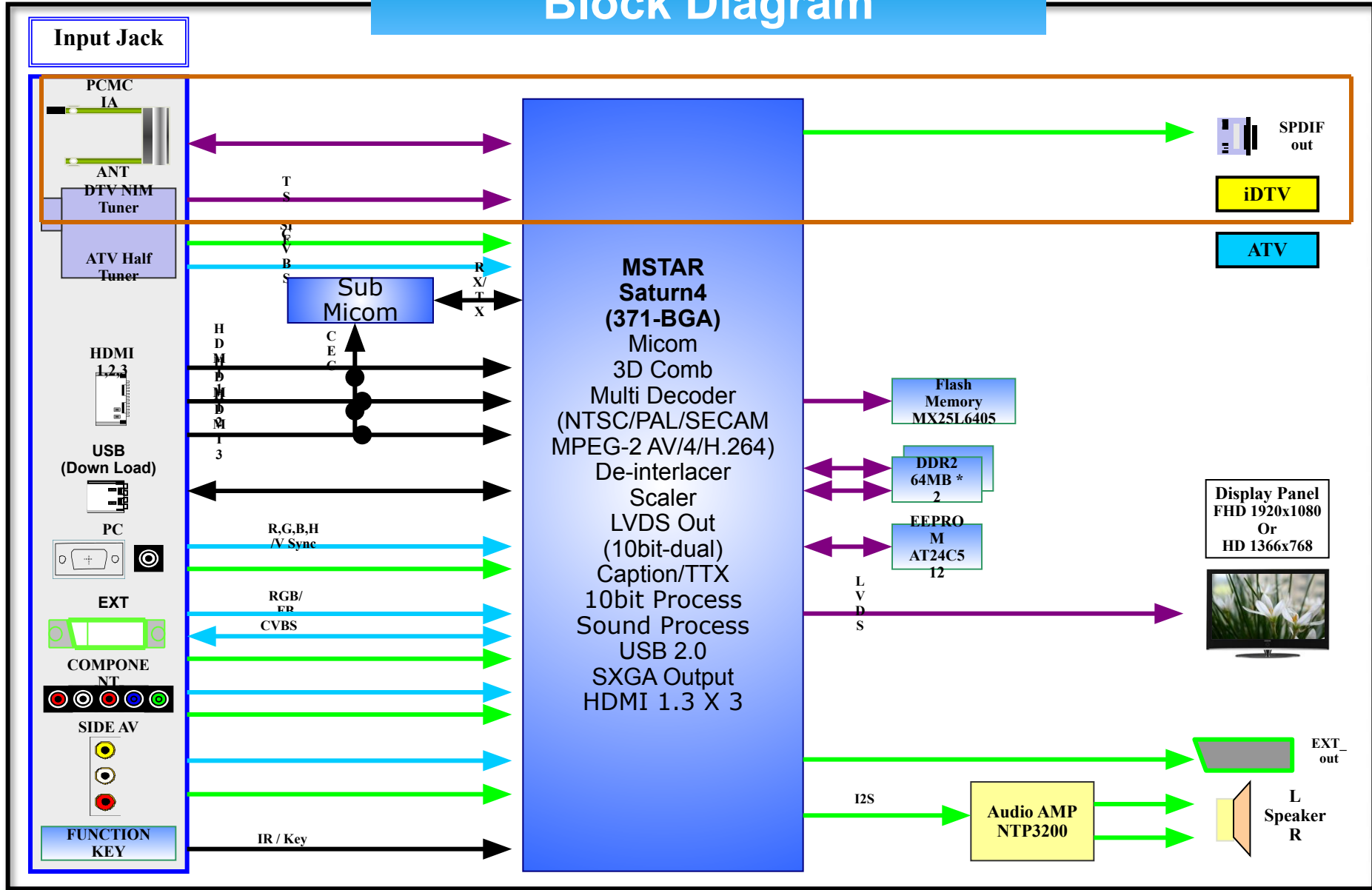

II. Inside of Models 26"/32"/37"/40"/46" Asia

Block Diagram

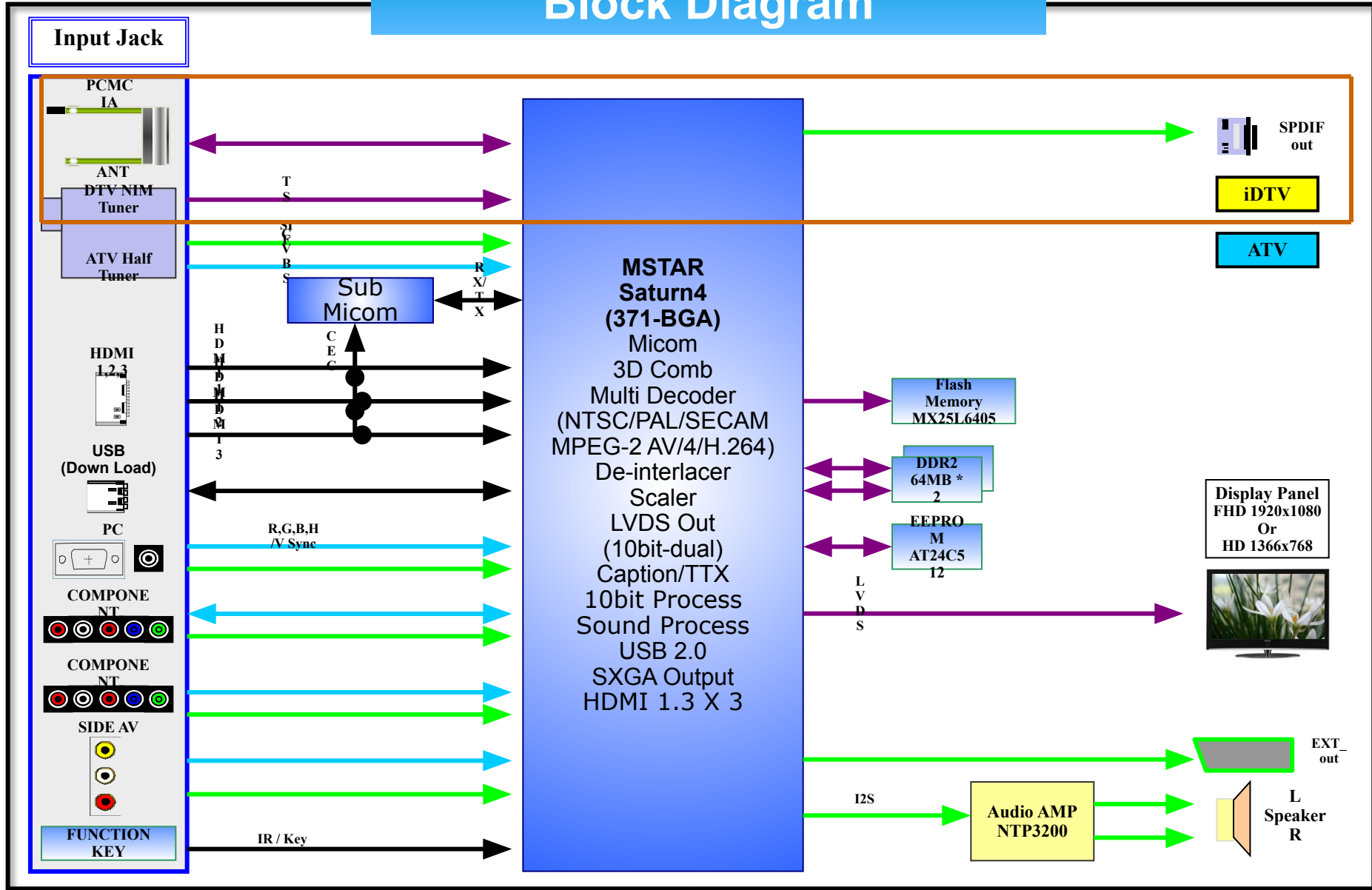

II. Inside of Model 19"/22" Europe

Block Diagram

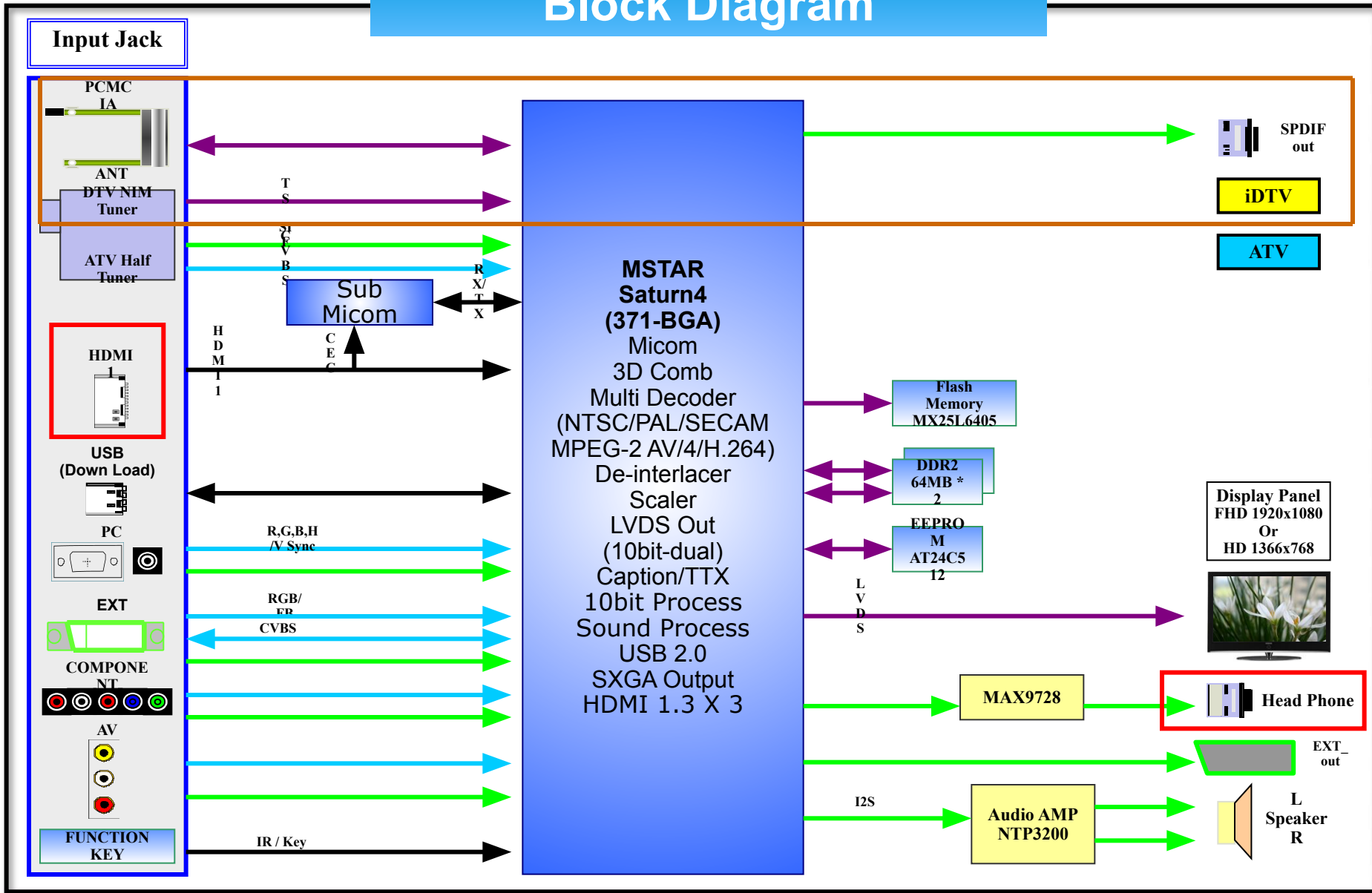

II. Inside of Model 19"/22" Asia

Block Diagram

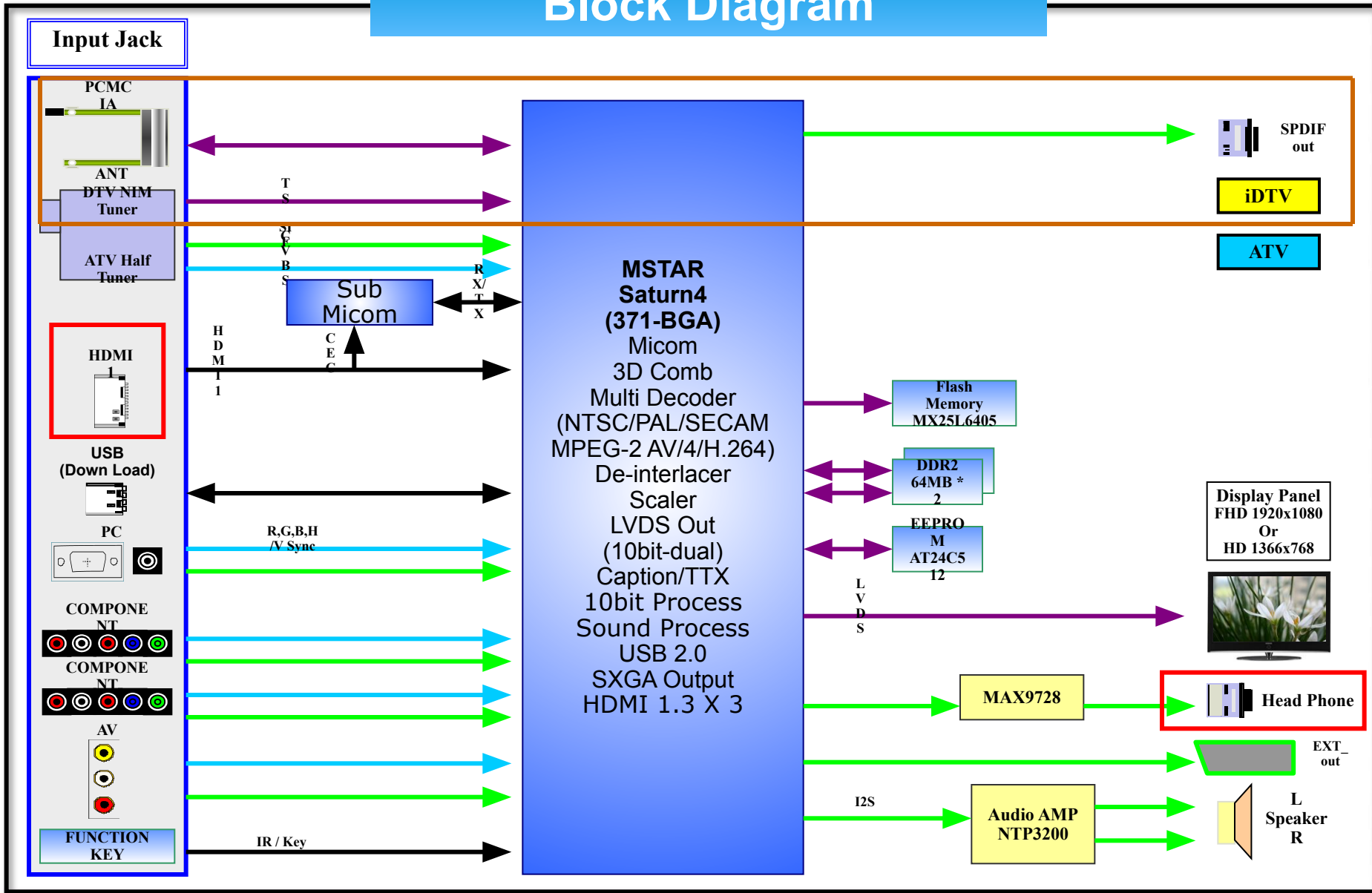

II. Inside of B350 Models 26"/32"

Block Diagram

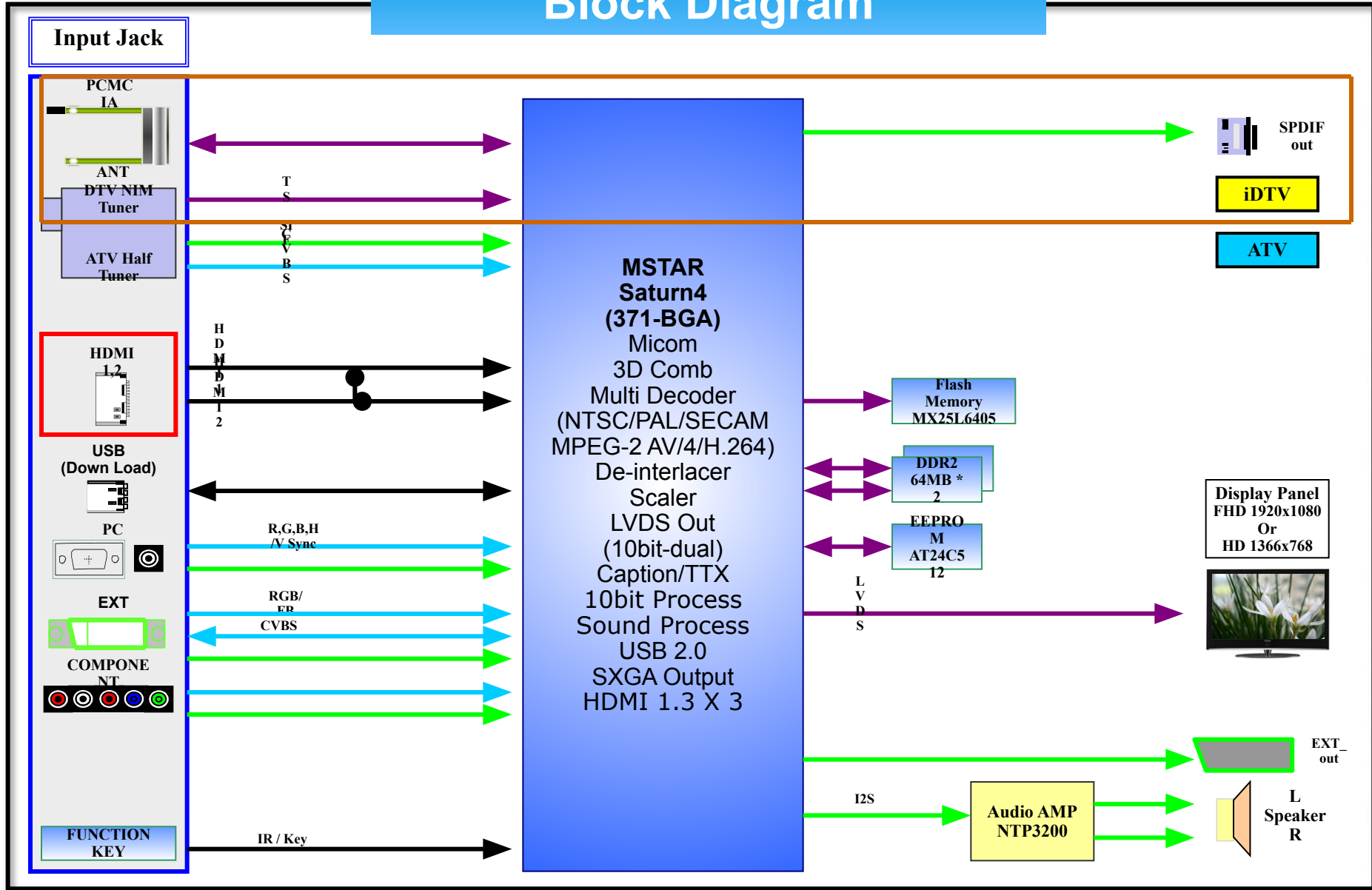

Inner Feature

- IP Board, Main Board, TCON Board, Panel

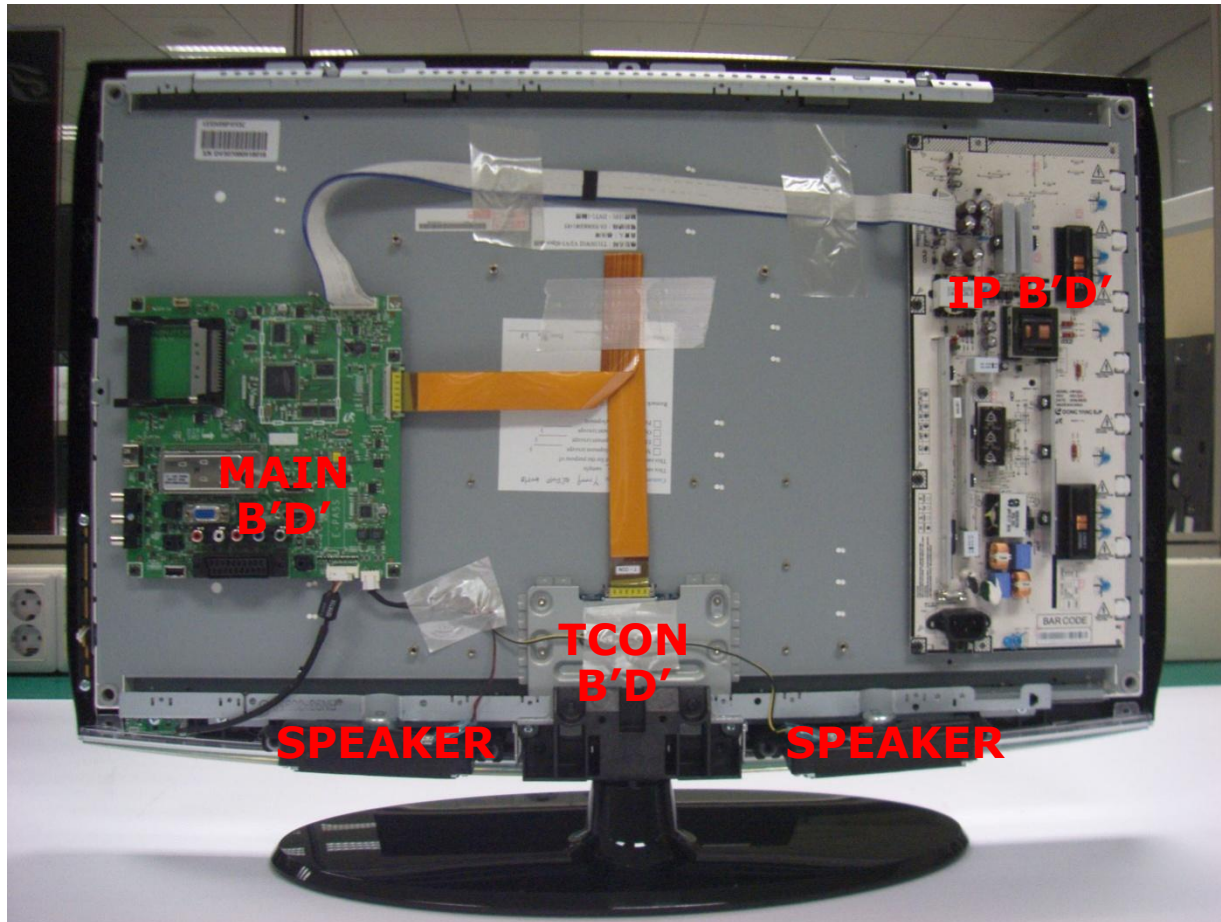

Audio description [From Wikipedia, the free encyclopedia]

Audio description refers to an additional [narration](#) track for [blind](#) and [visually impaired](#) consumers of visual media, including [television](#) and [movies](#), [dance](#), and [visual art](#).

For simplicity, this article focuses on the most common venues for description: [TV](#) and [film](#).

The description narrator talks through the presentation, describing what is happening on the screen during the natural pauses in the audio (and sometimes during dialogue if deemed necessary).

New Function : Audio Description

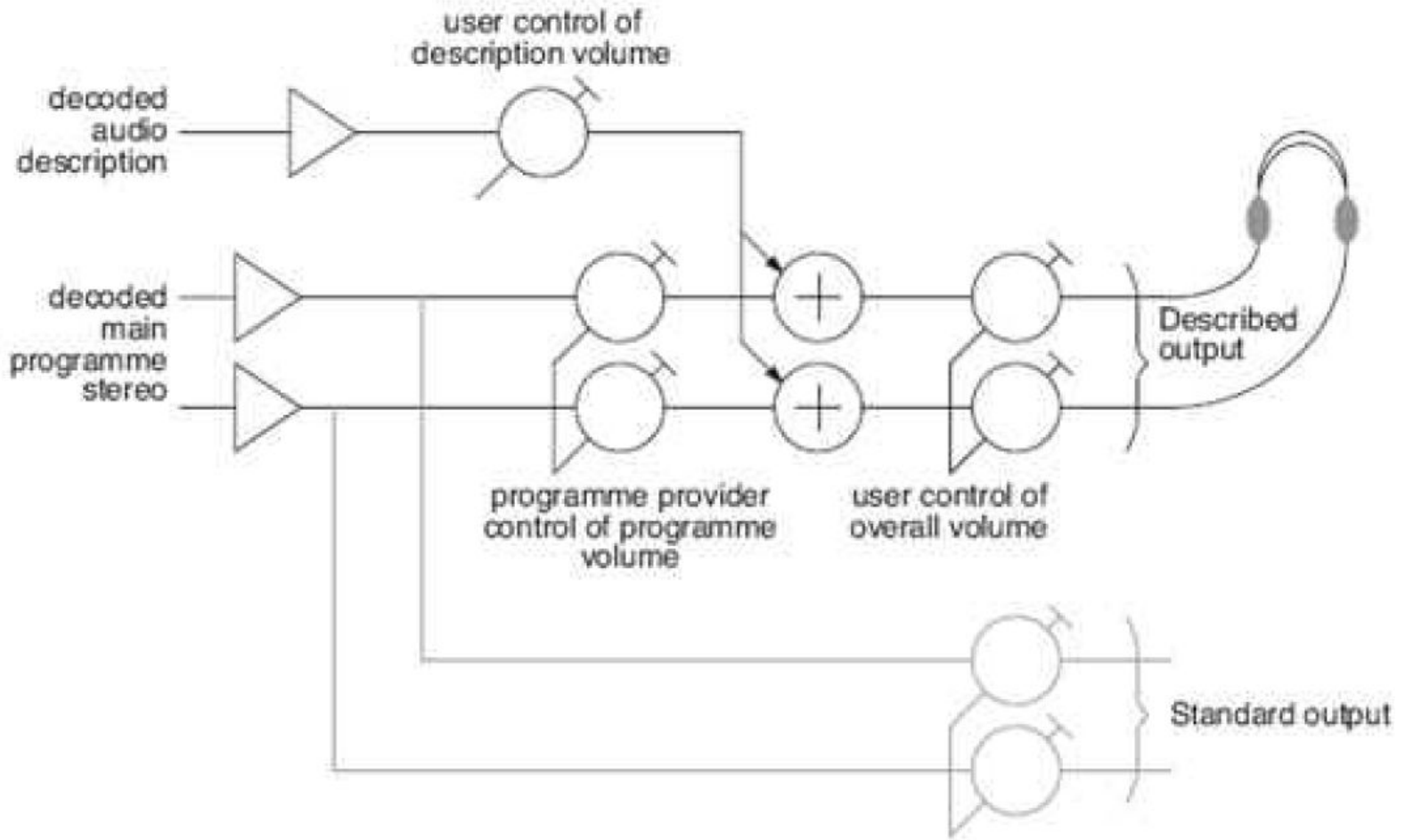

Audio encoding/compression

Dolby Digital (also known as AC-3): is a lossy audio compression format. It supports channel configurations from mono up to six discrete channels (referred to as "5.1"). This format first allowed and popularized surround sound. It was first developed for movie theater sound and spread to Laserdisc and DVD. It has been adopted in many broadcast formats including all North American digital television (ATSC), DVB-T, direct broadcast satellite, cable television, DTMB, IPTV, and surround sound radio services. It is also part of both the Blu-ray and the now defunct HD DVD standards. Dolby Digital is used to enable surround sound output by most video game consoles. Several personal computers support converting all audio to Dolby Digital for output.

Dolby Digital Plus: audio codec based on Dolby Digital that is backward compatible, but more advanced. The DVD Forum has selected Dolby Digital Plus as a standard audio format for HD DVD video. **It supports data rates up to 6 Mbyte/s, an increase from Dolby Digital's 640 kbit/s maximum.** Dolby Digital Plus is also optimized for limited data rate environments such as Digital broadcasting.

New Function : SRS TruSurround HD

Dialog Clarity. Audio creators today have more sound tools than ever to work with, and more channels to put sound in. So naturally, they create rich, dense audio for any purpose—movies, TV, music and games. Problem is, with such heavily layered audio tracks, sometimes the vocals and dialog get lost in the shuffle ... or buried under sound effects. Dialog Clarity boosts the frequency range of the human voice in a way that makes the human voice rise above the audio effects, so you can hear clearly every word you're supposed to hear.

Immersive Surround Sound. This is the core technology of all the TruSurround suites, and it processes any multichannel input, sending it to two or three TV speakers after some very sophisticated processing. This allows the listener to perceive enveloping surround sound from just the TV speakers or external speaker bar. Rear and surround channels are processed separately from front channels, and through our study of psychoacoustics and knowing the difference between how sound is perceived front to back, we process and adjust the surround channels' waveforms so they are perceived as coming from behind the listener.
, and the restoration really is magic.

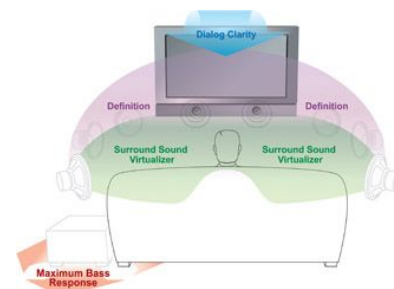

Improved Bass. We know small speakers cannot reproduce deep bass. It's physically impossible. But bass sounds are always accompanied by overtones, and if your ears are given all the overtones, your perception will fill in the 'missing fundamental.' SRS patented bass technology was developed based on an amazing combination of psychoacoustic understanding and technical know-how, managing to restore the sensation of deep bass. It identifies the signals that cannot be reproduced, and restores and boosts the overtones. It's all in your head, courtesy of some nifty audio wave processing, and the restoration really is magic.

High Frequency Clarity. Techniques used in digital compression or broadcast transmission can reduce the clarity of audio content, leaving you with a rather lackluster audio experience. SRS' premium high definition technology restores clarity by enhancing the high frequency content, bringing into focus the rain falling or wind howling in a movie scene or the cymbals and acoustic guitar strumming in your favorite song.

New Function : Self Diagnosis

1. Picture Test

Color Bar Test Pattern

2. Sound Test

Internal / External Speak

3. Signal Information

Frequency

Service ID

Multiplex

Network

Bit error level

Signal Strength

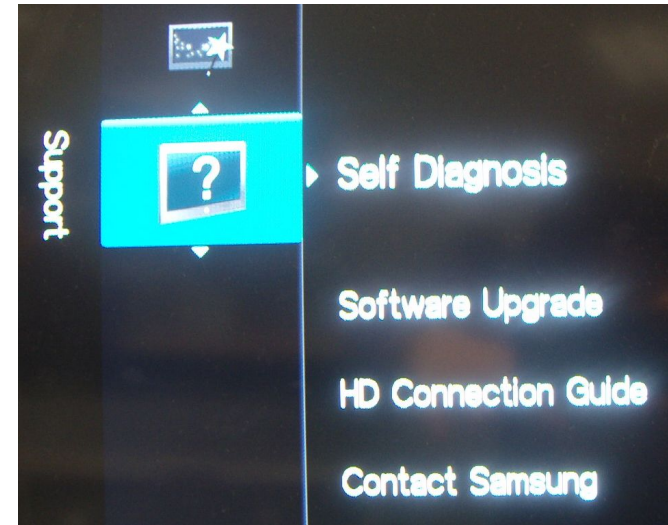

New Function : Self Diagnosis

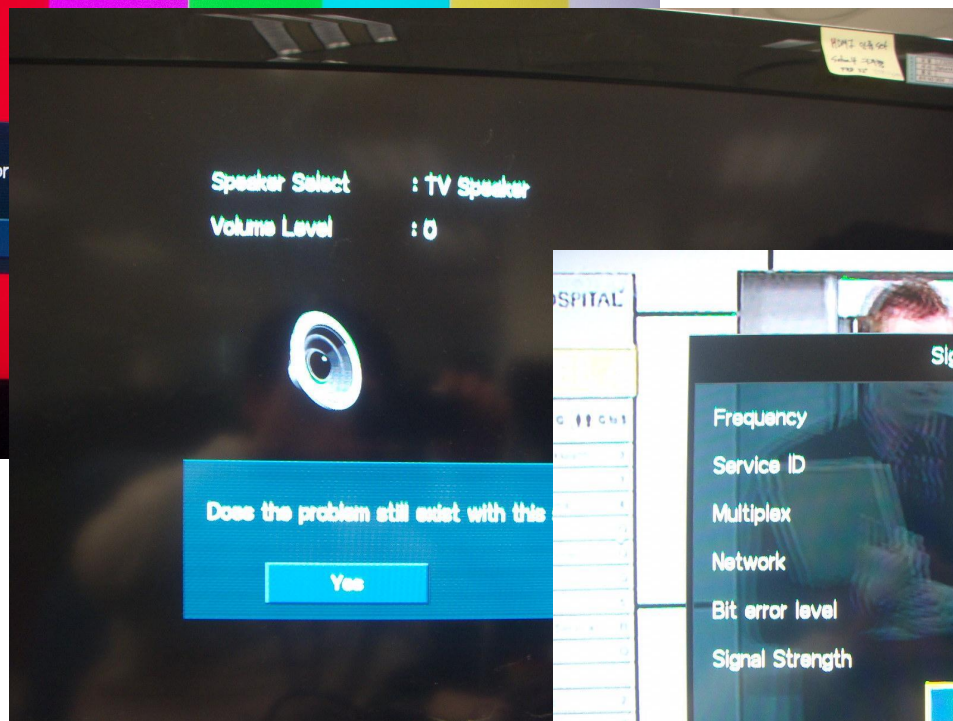
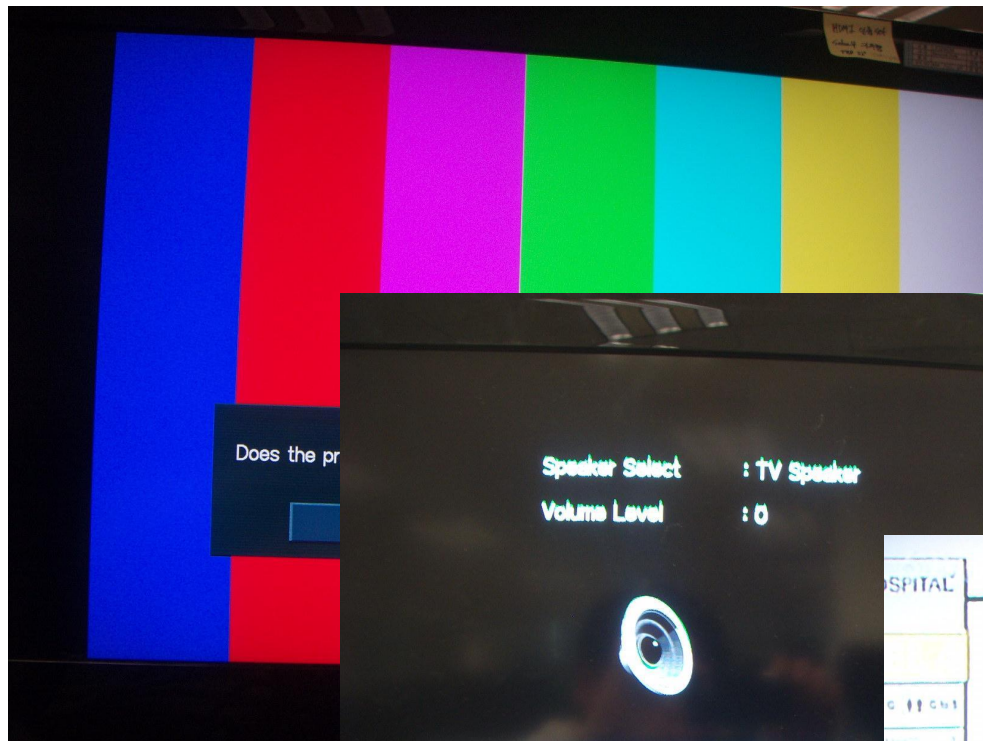

Software Upgrade

Current Version 2009/01/28_001000

If you select 'Alternative Software',
then the Current Version will be swapped
with Alternative Software.

In this case, Ver.152 will be installed.

By USB

By Channel

Standby Mode Upgrade : 45 Min

Alternative Software : 28526/95/66_000152 ▶

OSD Menu Tree

Project Name:	Saturn4 DVB
Created:	
Product:	LCD TV
System:	DVB(2009)
Date:	2008-11-26



OSD MENU
TREE

Key parts

SCALER : SEMS12

SOUND AMP : NTP3200

SCALER: SEMS12

GENERAL DESCRIPTION

The SEMS12 is a highly integrated controller IC for LCD/PDP DTV applications with resolutions up to full-HD (1920 x 1080). It is configured with an integrated triple-ADC/PLL, a multi-standard TV video and audio decoder, a motion adaptive video de-interlacer, a scaling engine, the MStarACE-3 color engine, an advanced 2D graphics engine, a transport processor, a high-definition (HD) MPEG video decoder, a high-definition (HD) H.264 video decoder, a RealVideo decoder, a JPEG video decoder, an MPEG-4 decoder, and a 24-bit DSP for MPEG audio decoding, a DVI/HDCP/HDMI receiver, and a peripheral control unit providing a variety of HDTV control functions.

For digital TV application, the SEMS12 comprises an MPEG-2 transport processor with advanced section filtering capability, an MPEG-2 (MP@HL profile) video decoder, an MPEG-4 decoder, an H.264 video decoder, and an audio DSP decoder for MPEG audio streams, MPEG layer I and II digital audio decoder with analog audio outputs that are designed to support existing and future DVB-T programs while handling conditional access. Furthermore, it is also possible to decode JPEG, RealVideo streams, and MP3 formats from external sources such as USB interface.

SCALER: SEMS12

FEATURES

↳ Transport Stream De-multiplexer

1. Two external TS inputs and one internal TS data path
2. Supports both parallel and serial TS interface, with or without sync signal Maximum TS data rate is 104 Mb/sec for serial or 13 MB/sec for parallel 32 general purpose PID filters and section filters for each transport stream de-multiplexer
3. One video PES and two audio PES channels
4. Supports MHEG5, DVB subtitle and digital teletext

↳ MPEG-2 Video Decoder

1. ISO/IEC 13818-2 MPEG-2 video MP@HL
2. Automatic frame rate conversion
3. Supports resolution in HDTV (1080i, 720p) and SDTV
4. MPEG-1, MPEG-2 (Layer I/II), Dolby1 Digital (AC-3), AAC and HE-AAC audio decoder
5. Optionally supports Dolby Digital Plus (E-AC-3)2 decoding

SCALER: SEMS12

☞ MPEG-4 Video Decoder

1. ISO/IEC 14496-2 MPEG-4 ASP video decoding
2. Supports resolution in HDTV (1080p@30fps) for MPEG-4

☞ H.264 Decoder

1. Fully compliant with ITU-T H.264, ISO/IEC 14496-10 (main and high profile up to level 4.0)
2. Supports all DVB, ATSC, HDTV, DVD, VCD resolutions (e.g. 1080p, 1080i, 720p, D1)
3. Supports picture size from 80x96 pixel to 1920x1088 pixel
4. Decodes up to 1080p@30 fps
5. Reads streams from Transport and from files
6. Supports stream types of CABAC and CAVLC
7. Processing of ES and PES streams, extraction and provision of time stamps
8. Allegro H.264 certification test suite proven
9. ITU-T H.264 conformance tests proven
10. Error detection and concealment

SCALER: SEMS12

☞ NTSC/PAL/SECAM Video Decoder

1. Supports NTSC-M, NTSC-J, NTSC-4.43, PAL (B,D,G,H,M,N,I,Nc), and SECAM
2. Automatic TV standard detection
3. Motion adaptive 3-D comb filter for NTSC/PAL
4. Eight configurable CVBS & Y/C S-video inputs
5. Supports Closed Caption (analog CC 608/analog CC 708/digital CC 608/digital CC 708), V-chip and SCTE
6. Two CVBS video outputs

☞ Digital Audio Interface

1. I2S digital audio input & output
2. S/PDIF digital audio input & output
3. HDMI audio channel processing capability
4. Programmable delay for audio/video synchronization

SCALER: SEMS12

☞ Multi-Standard TV Sound Processor

1. Supports BTSC/A2/EIA-J demodulation in NTSC and A2/NICAM/FM/AM demodulation in PAL
2. Supports MTS Mode Mono/Stereo/SAP in BTSC/ EIA-J and Mono/Stereo/Dual in A2/NICAM
3. L/R audio line-in x6 and SIF audio input
4. L/R speaker and 2 additional L/R audio line-out
5. Built-in audio sampling rate conversion (SRC)
6. Built-in audio output DAC's
7. Supports audio description (AD)
8. Audio processing for loudspeaker channel, including volume, balance, mute, tone, EQ, virtual stereo/surround, and treble/bass
9. Supports MP3 decoding
10. Optionally supports Dolby Digital (AC-3) encoding at SPDIF output
11. Optional advanced sound3 available (Dolby, SRS4, BBE5... etc)

SCALER: SEMS12

☞ Analog RGB Compliant Input Ports

1. Three analog ports support up to 1080P
2. Supports PC RGB input up to UXGA@60Hz
3. Supports HDTV RGB/YPbPr/YCbCr
4. Supports Composite Sync and SOG (Sync-on-Green) separator
5. Automatic color calibration

☞ VIF Input Support

1. Multi-standard analog TV receiver applications
2. Digital low IF architecture
3. Stepped-gain PGA with 25 dB tuning range and 1 dB tuning resolution
4. Maximum IF gain of 37 dB
5. Programmable TOP to accommodate different tuner gain to optimize noise and linearity performance

SCALER: SEMS12

☞ DVI/HDCP/HDMI Compliant Input Port

1. Three DVI/HDCP/HDMI input ports support up to 225MHz @ 1080P 60Hz with 12-bit deep-color resolution
2. Single link on-chip DVI 1.0 compliant receiver
3. High-bandwidth Digital Content Protection (HDCP) 1.1 compliant receiver
4. High Definition Multimedia Interface (HDMI) 1.3 compliant receiver with CEC (Consumer Electronics Control) support
5. Long-cable tolerant robust receiving

☞ High-Performance Scaling Engine

1. Fully programmable shrink/zoom capabilities
2. Nonlinear video scaling supports various modes including Panorama

SCALER: SEMS12

☞ Video Processing & Conversion

1. 3-D motion adaptive video de-interlacers with edge-oriented adaptive algorithm for smooth low-angle edges
2. Automatic 3:2 pull-down & 2:2 pull-down detection and recovery
3. MStar 3rd Generation Advanced Color Engine (MStarACE-3) automatic picture enhancement gives:
 - a. Brilliant and fresh color
 - b. Intensified contrast and details
 - c. Vivid skin tone
 - d. Sharp edge
 - e. Enhanced depth of field perception
 - f. Accurate and independent color control
4. sRGB compliance allows end-user to experience the same colors as viewed on CRTs and other displays
5. 3-channel gamma curve adjustment
6. 10-bit internal data processing

SCALER: SEMS12

☞ Hardware JPEG

1. Supports sequential mode, single scan
2. Supports both color and grayscale picture
3. Operates in scan unit; hardware decoder will handle the bit stream after scan header
4. Supports programmable region of interest (ROI)
5. Supports format: 422/411/420/444/422T
6. Decoded picture will be stored in DRAM with UYVY format
7. Supports scaling down ratio: 1/2, 1/4, 1/8, applied to height and width simultaneously

☞ Output Interface

1. Supports up to 10-bit dual LVDS full-HD (1920 x 1080) panel interface
2. Supports 2 data output formats: Thine & TI data mappings
3. Compatible with TIA/EIA With 6/8 bits optional dithered output
4. Spread spectrum output frequency for EMI suppression

SOUND AMP:NTP3200

Features

- Stereo (20W x 2)
- Wide Supply Voltage Range (7.5V~24V)
- Floating Point Operation
- 16 Programmable Bi-quad Filters
 - Speaker Compensation
 - DC cut, LPF, HPF
 - Parametric Equalizer
- 100 dB Dynamic Range
- Adaptive Loudness Compensator based on Psycho Acoustics
- Dynamic range control
- Loudness

- Protection Circuit
 - OCP (Over Current Protection)
 - OTP (Over Temperature Protection)
 - UVP (Under Voltage Protection)

SOUND AMP:NTP3200

Description

The NTP-3200 is a single chip full digital audio amplifier including power stage for stereo amplifier system. NTP-3200 is integrated with versatile digital audio signal processing functions, high-performance, high-fidelity fully digital PWM modulator and two high-power full bridge MOSFET power stages.

The NTP-3200 receives digital serial audio data with sampling frequency from 8KHz to 192KHz. It delivers 2 x 20 watt in stereo mode without heat sink. The NTP-3200 has mixer and Bi-Quad filters which can be used to implement the essential audio signal processing functions like loudness control, loud speaker response compensation and parametric equalizers.

All the functions of the NTP-3200 can be controlled by internal register values via I2C host interface bus.

II. Inside of New Model

SOUND AMP:NTP3200

Package

56 pin MLF 8mm by 8mm

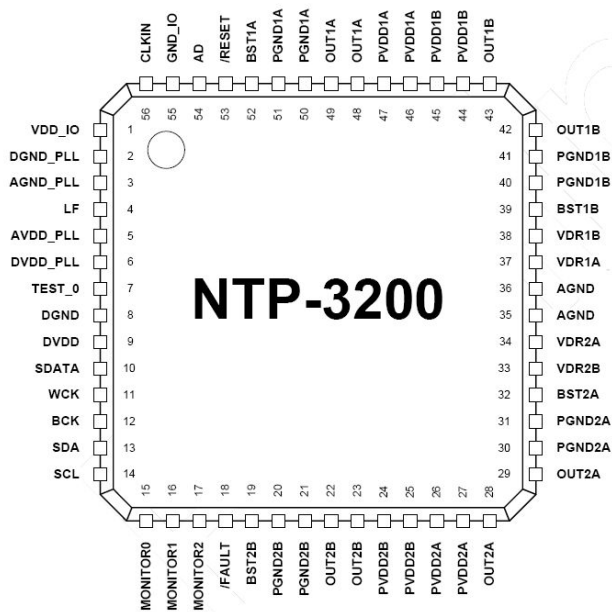

BLOCK DIAGRAM

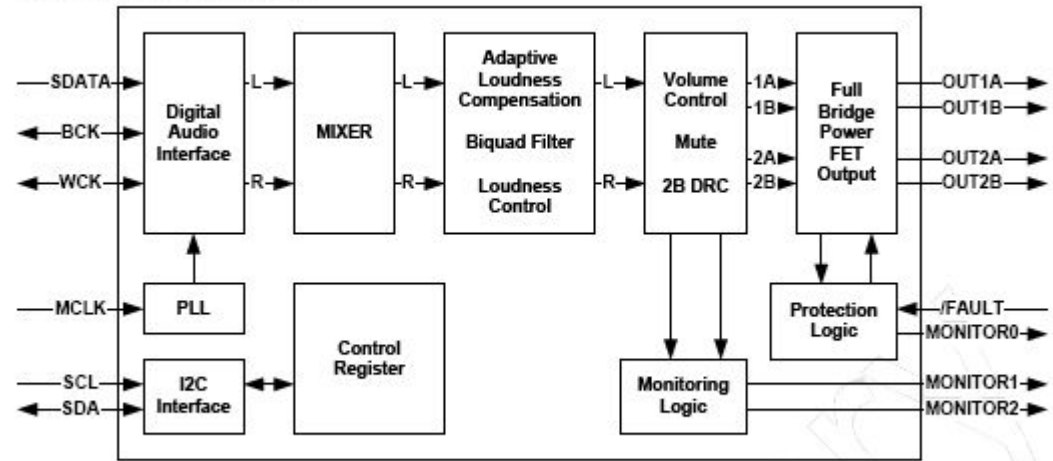

Figure 1. NTP-3200 Block Diagram

SOUND AMP:NTP3200

3. PIN DESCRIPTIONS

PIN	NAME	TYPE	DESCRIPTION
1	VDD_IO	P	Power supply for digital interface I/O, 3.3V
2	DGND_PLL	P	Ground for PLL digital block
3	AGND_PLL	P	Ground for PLL analog block
4	LF	I/O	External loop filter
5	AVDD_PLL	P	Power supply for PLL analog block, 1.8V
6	DVDD_PLL	P	Power supply for PLL digital block, 1.8V
7	TEST_0	I	Connect to GND
8	DGND	P	Ground for Core block
9	DVDD	P	Power supply for core block, 1.8V
10	SDATA	I	I ² S serial data input
11	WCK	I/O	I ² S word clock
12	BCK	I/O	I ² S bit clock
13	SDA	I/O	I ² C Data I/O
14	SCL	I	I ² C Clock
15	MONITOR0	O	Monitor out 0 (PWM_MASK)
16	MONITOR1	O	Monitor out 1
17	MONITOR2	O	Monitor out 2
18	/FAULT	I	Active low to reset internal power stage, Pull-up
19	BST2B	P	Bootstrap supply, External capacitor to connect with OUT2B is required
20	PGND2B	P	Ground for Power stage 2B

SOUND AMP:NTP3200

PIN DESCRIPTIONS

21	PGND2B	P	Ground for Power stage 2B
22	OUT2B	O	PWM output 2B
23	OUT2B	O	PWM output 2B
24	PVDD2B	P	Power supply for PWM Power stage 2B
25	PVDD2B	P	Power supply for PWM Power stage 2B
26	PVDD2A	P	Power supply for PWM Power stage 2A
27	PVDD2A	P	Power supply for PWM Power stage 2A
28	OUT2A	O	PWM output 2A
29	OUT2A	O	PWM output 2A
30	PGND2A	P	Ground for Power stage 2A
31	PGND2A	P	Ground for Power stage 2A
32	BST2A	P	Bootstrap supply, External capacitor to OUT2A is required
33	VDR2A	P	Gate drive voltage regulator decoupling pin, capacitor to GND is required
34	VDR2B	P	Gate drive voltage regulator decoupling pin, capacitor to GND is required
35	AGND	P	Ground for Power stage
36	AGND	P	Ground for Power stage
37	VDR1A	P	Gate drive voltage regulator decoupling pin, capacitor to GND is required
38	VDR1B	P	Gate drive voltage regulator decoupling pin, capacitor to GND is required
39	BST1B	P	Bootstrap supply, External capacitor to OUT1B is required
40	PGND1B	P	Ground for Power stage 1B

SOUND AMP:NTP3200

PIN DESCRIPTIONS

41	PGND1B	P	Ground for Power stage 1B
42	OUT1B	O	PWM output 1B
43	OUT1B	O	PWM output 1B
44	PVDD1B	P	Power supply for PWM Power stage 1B
45	PVDD1B	P	Power supply for PWM Power stage 1B
46	PVDD1A	P	Power supply for PWM Power stage 1A
47	PVDD1A	P	Power supply for PWM Power stage 1A
48	OUT1A	O	PWM output 1A
49	OUT1A	O	PWM output 1A
50	PGND1A	P	Ground for Power stage 1A
51	PGND1A	P	Ground for Power stage 1A
52	BST1A	P	Bootstrap supply, External capacitor to OUT1A is required
53	/RESET	I	Assert low to reset, Schmitt trigger input
54	AD	I	I ² C device address selection
55	GND_IO	P	Ground for digital interface I/O
56	CLKIN	I	System master clock, Schmitt trigger input

P = Power, I = Input, O = Output, I/O = Input / Output

BOARD DESCRIPTION



CONTENTS

1. MAIN BOARD LAYOUT
2. MAIN BOARD PIN CHARACTERISTIC
3. IP BOARD INPUT CHARACTERISTIC
4. POWER OUTPUT CHARACTERISTIC
5. INVERTER OUTPUT CHARACTERISTIC
6. ENVIRONMENTAL CHARACTERISTIC
7. IP BOARD LAYOUT
8. IP BOARD PIN CHARACTERISTIC

III. Board description

1. MAIN BOARD LAYOUT

FHD 32"/37"/40"/46" MAIN BOARD

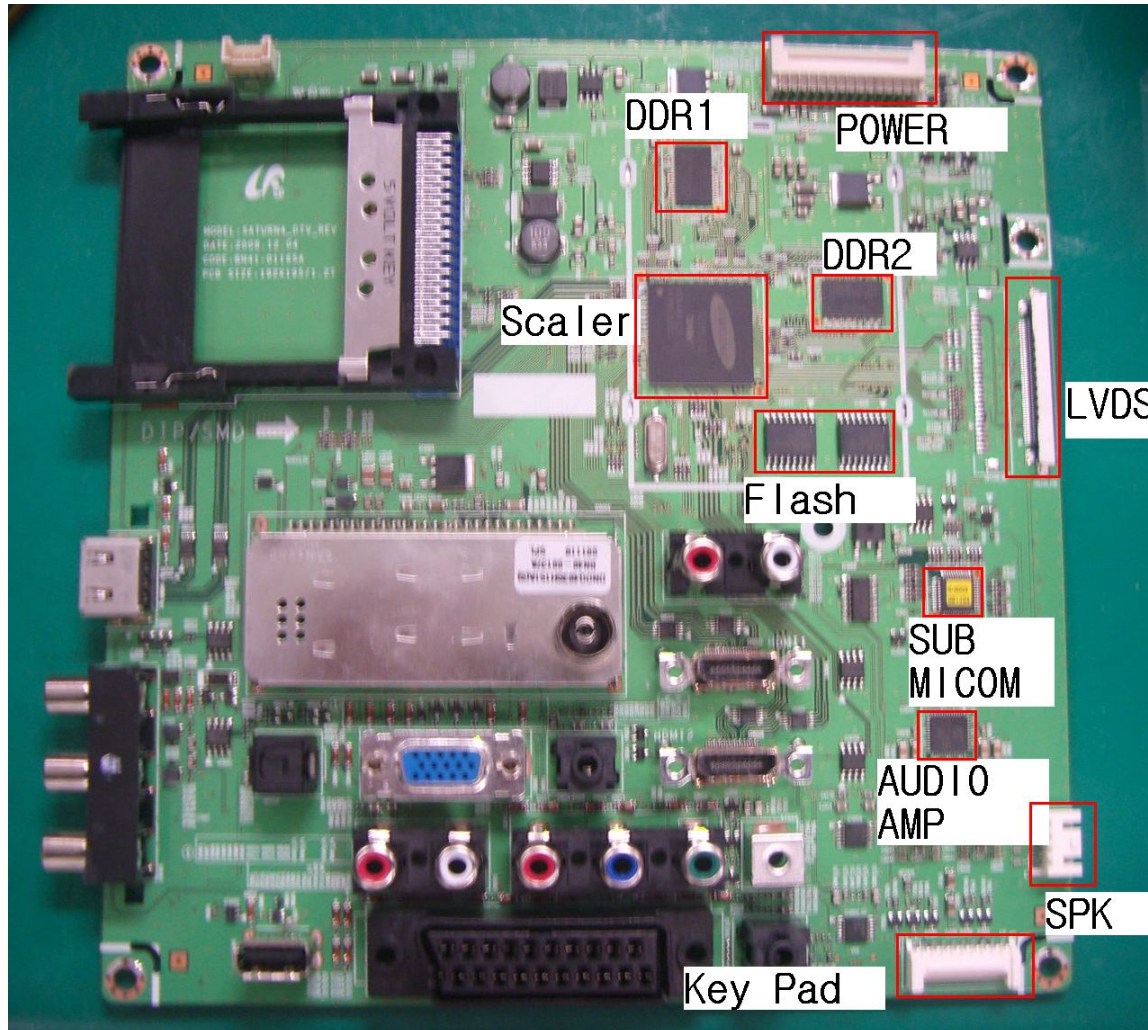

192*195

III. Board description

1. MAIN BOARD LAYOUT

HD 26"/32" MAIN BOARD

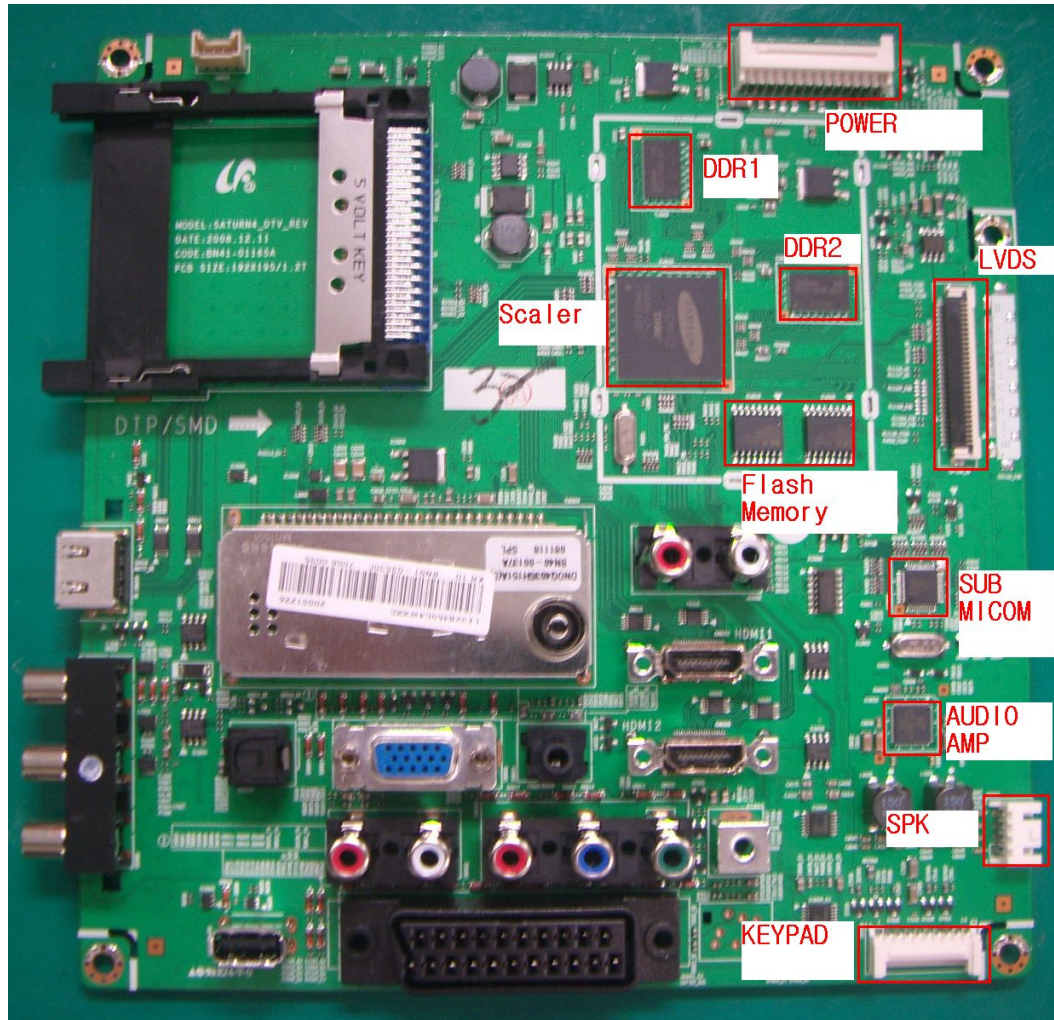

192*195
Mirror

III. Board description

1. MAIN BOARD LAYOUT

HD 19"/22" MAIN BOARD

9P

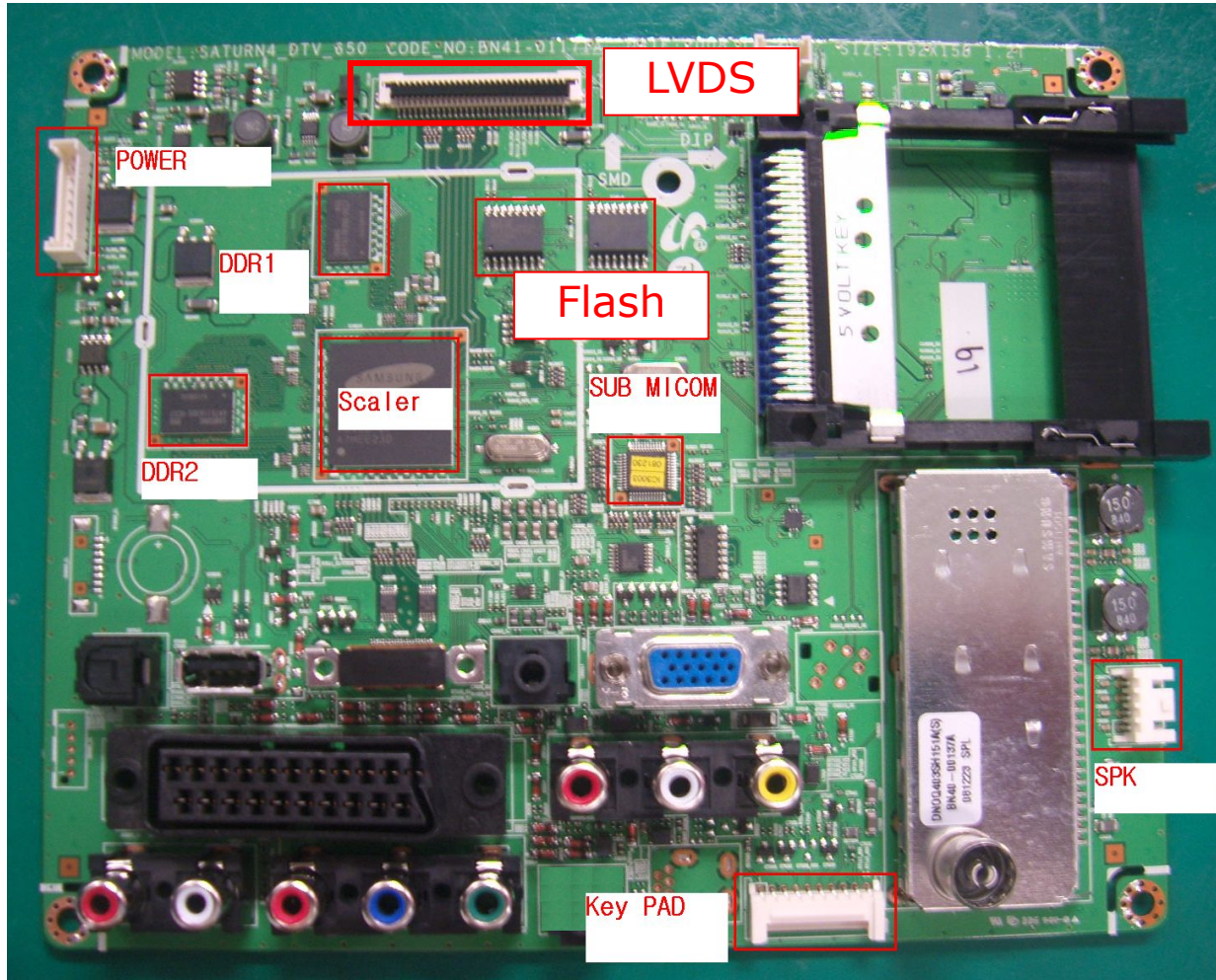

Audio AMP
is in the
Bottom

192*158
Normal

III. Board description

1. MAIN BOARD LAYOUT

HD B350 26"/32" MAIN BOARD

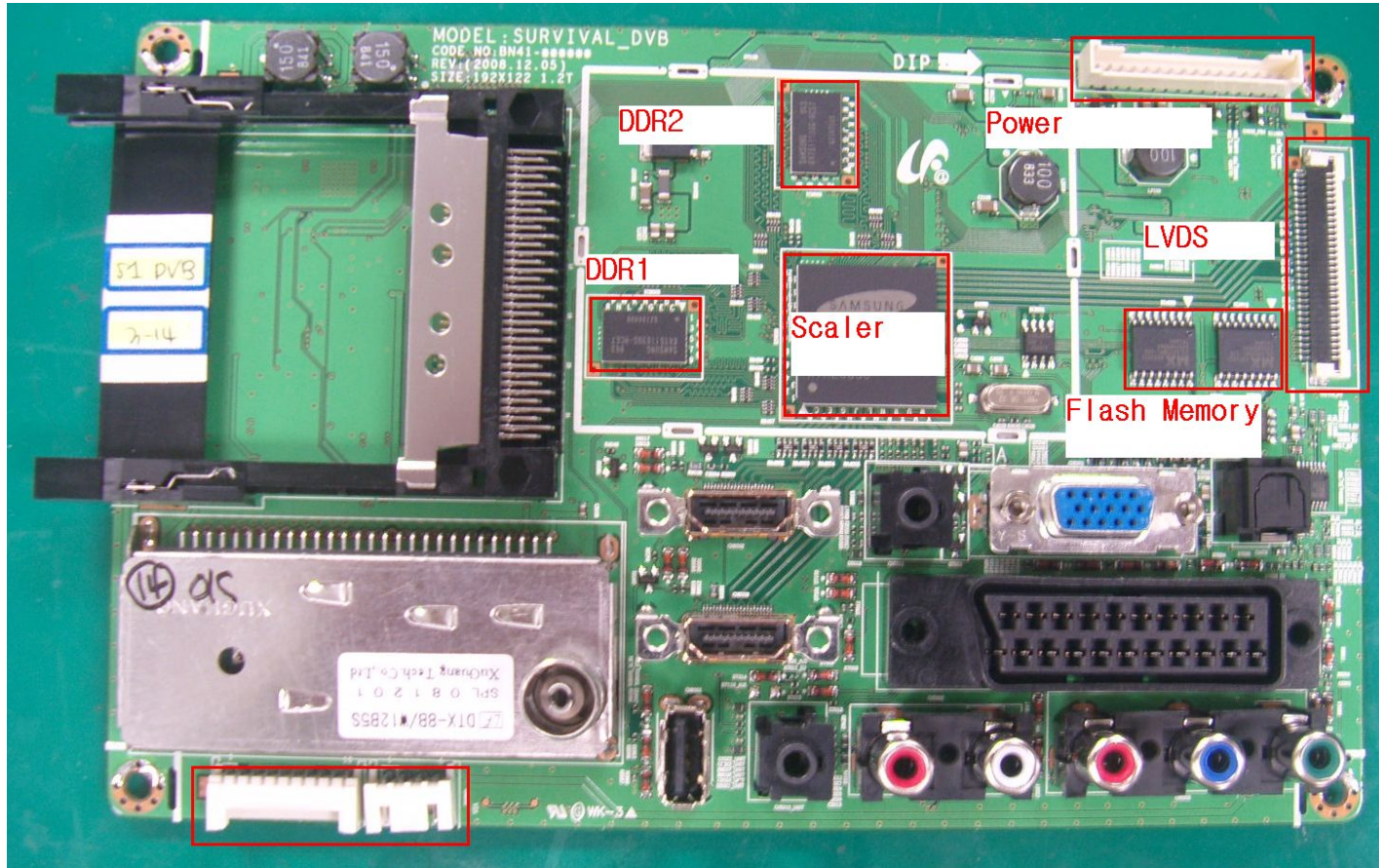

Audio AMP
is in the
Bottom

192*122
Mirror

1. MAIN BOARD LAYOUT

FHD 32"~46" ASIA DTV MAIN BOARD

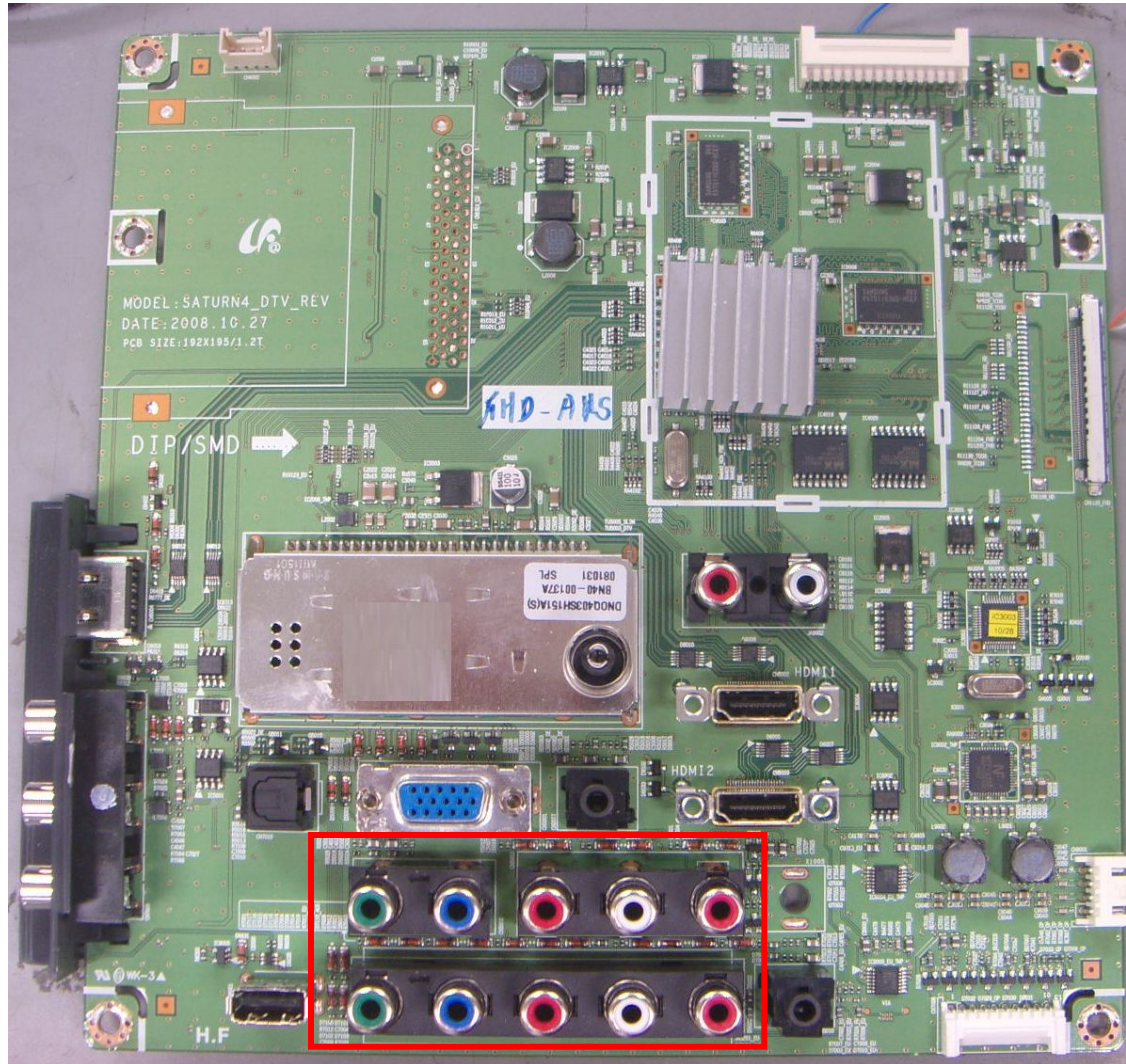

Difference
is only
Input Jack
comparing
with
Europe
FHD Model

1. MAIN BOARD LAYOUT

HD 19"~22" ASIA DTV MAIN BOARD

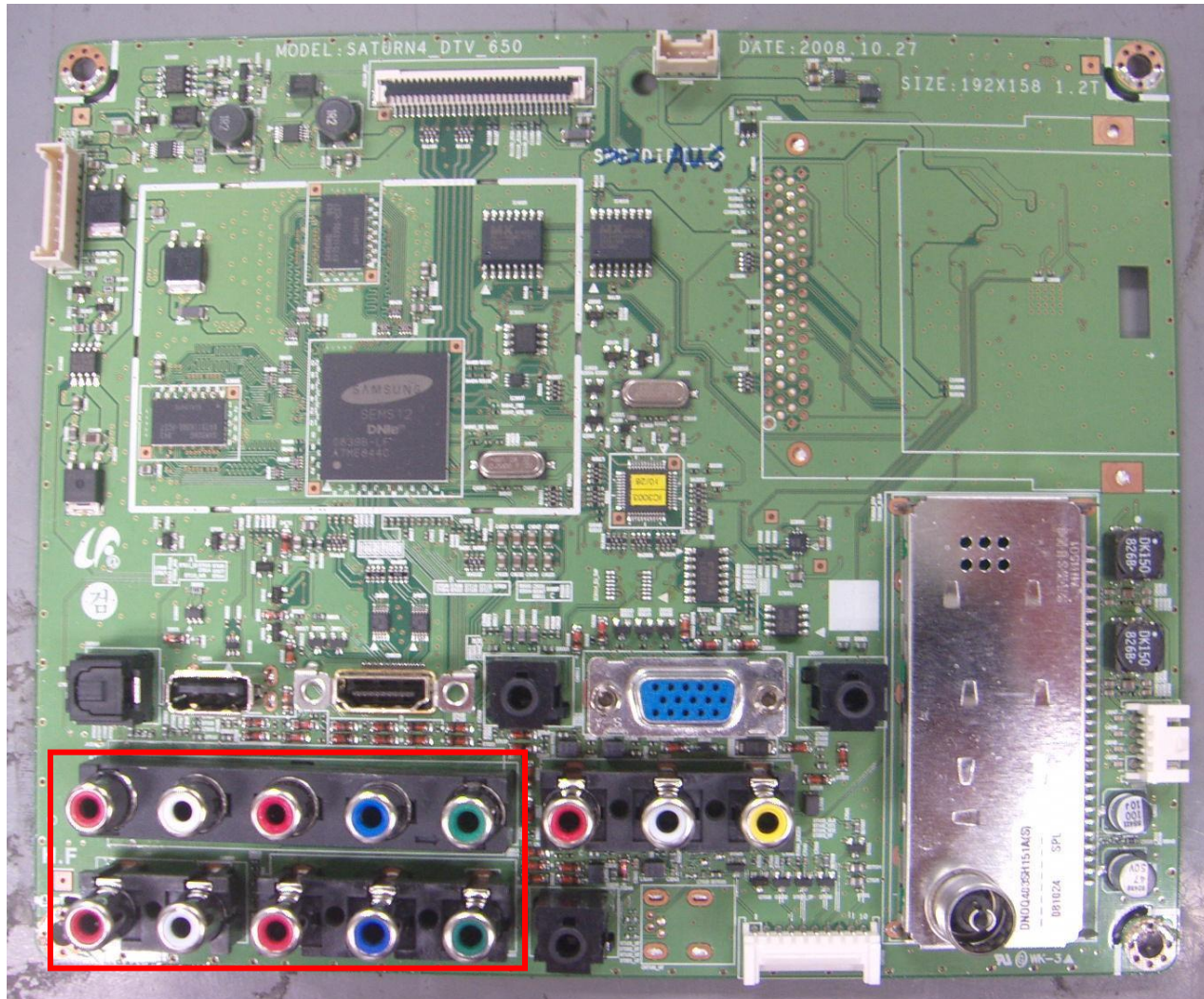

Difference is only Input Jack comparing with Europe HD Model

III. Board description

2. MAIN BOARD PIN CHARACTERISTIC

Main Board power supply : 26" ~ 46"

PIN	1	2	3	4	5	6	7	8	9	10	11	12	13	14
NAME	HSYNC	SW_POWER	GND	A5V	GND	GND	B13VS	B13VS	GND	GND	GND	GND	B5V	B5V

PIN	15	16	17	18	19	20	21	22	23	24	25	26
NAME	B5V	B5V	GND	GND	GND	B13V	B13V	B13V	ANA_DIMMING	SW_INVERTER	GND	PWM_DIMMING

PIN	27	28	29	30
NAME	NC	LAMP_DETECT	NC	NC

12	13	14	15	16
SW_INV	Dimming	LAMP_DET	GND	GND

Main Board power supply : B350 26" ~ 32"

PIN	1	2	3	4	5	6	7	8	9
NAME	SW_POWER	A13V	GND	GND	GND	A5V	A5V	SW_POWER	SW_INVERTER

Main Board power supply : 19" ~ 22"

PIN	1	2	3	4	5	6	7	8	9	10	11
NAME	SW_POWER	A5V	GND	A13V	GND	GND	A5V	A5V	GND	A13V	A11V

SPEAKER CONNECTOR

PIN	1	2	3	4
NAME	L- OUT	L+ OUT	R- OUT	R+ OUT

Dimming

- Analog Dimming ; Current Amplitude Control
- PWM Dimming
 1. I-PWM ; DC(0~3.3V) signal
 2. E-PWM ; Pulse signal

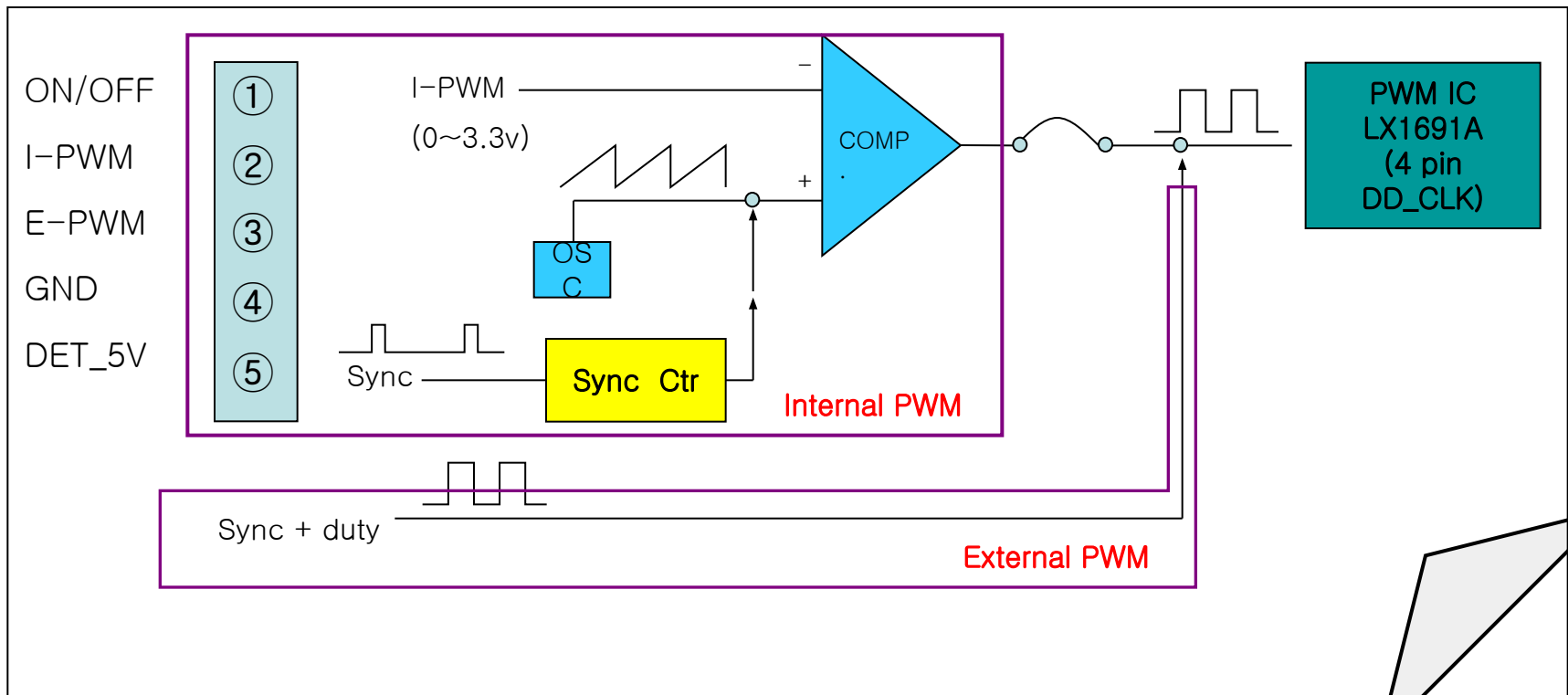

III. Board description

▪ LAMP DETECT

When TV set turns on, main Micom checks this pin 3 times with 200ms interval after 2 sec wait.

If the pin has low level for 600ms, Micom makes inverter switch off and on after 500ms wait.

If it is low level during 4Sec, then Micom makes inverter switch off and on after 500ms wait.

If it is low level during 4Sec, then Micom makes inverter switch off and on after 500ms wait.

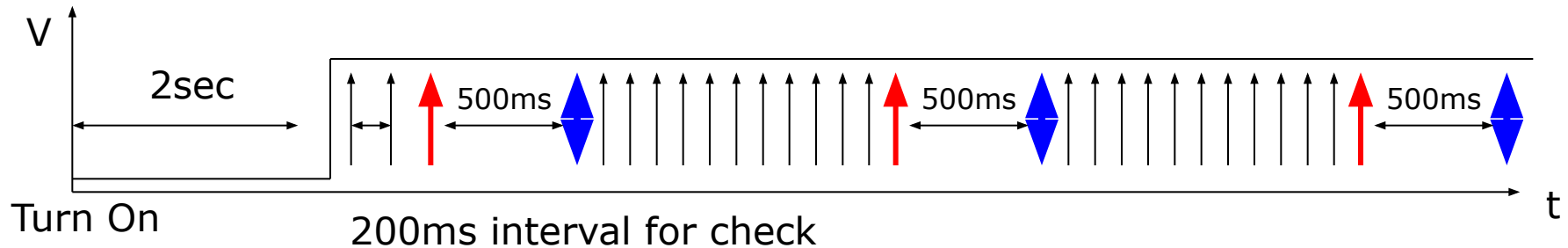

This Lamp detection function is always working on after booting, and Inverter off and on control can be shown only 3 times.

2. MAIN BOARD PIN CHARACTERISTIC

CN3002-Front control

PIN	1	2	3	4
NAME	IR	GND	A5V	LED_STB
PIN	5	6	7	8
NAME	NC	KEY_INPUT 1	KEY_INPUT2	GND

FUNCTIONING DEFINE:

- A5V Front control board power supply
- KEY INPUT1,2 key control, form the Menu , channel up/down Etc.
- IR remote control signal
- LED_STB control the timing and standby LED color

2. MAIN BOARD PIN CHARACTERISTIC

CN6001_T - HD LVDS Digital Signal

PIN	1	2	3	4	5	6
NAME	PANEL_VCC	PANEL_VCC	PANEL_VCC	PANEL_VCC	PANEL_VCC	NC
PIN	7	8	9	10	11	12
NAME	GND	GND	RESET_TCON	GND	NC	GND
PIN	13	14	15	16	17	18
NAME	LVDS_TX3+	LVDS_TX3-	GND	LVDS_TXCLK+	LVDS_TXCLK-	GND
PIN	19	20	21	22	23	24
NAME	LVDS_TX2+	LVDS_TX2-	GND	LVDS_TX1+	LVDS_TX1-	GND
PIN	25	26	27	28	29	30
NAME	LVDS_TX0+	LVDS_TX0-	GND	SDA_TCON	SCL_TCON	WPN

FANET: Reads the T-CON BD EEPROM

Reduces the tact time including W/B,
F/Option setting and Protects service error

III. Board description

1. Sequence Spec_Power

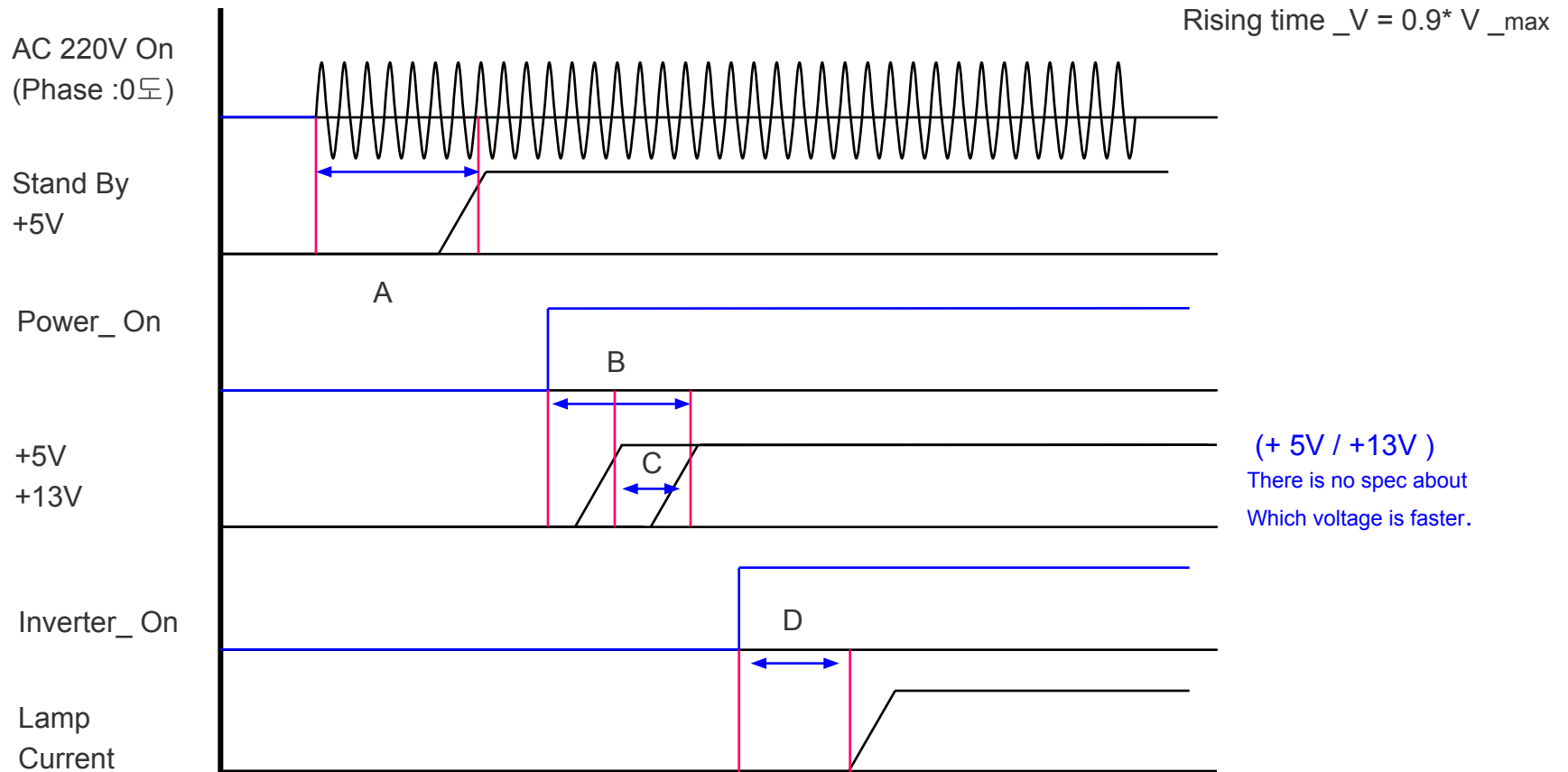

Spec	MIN (msec)	MAX (msec)
A	100	1200
B	10	500
C	0.01	20m
D	10	300

III. Board description

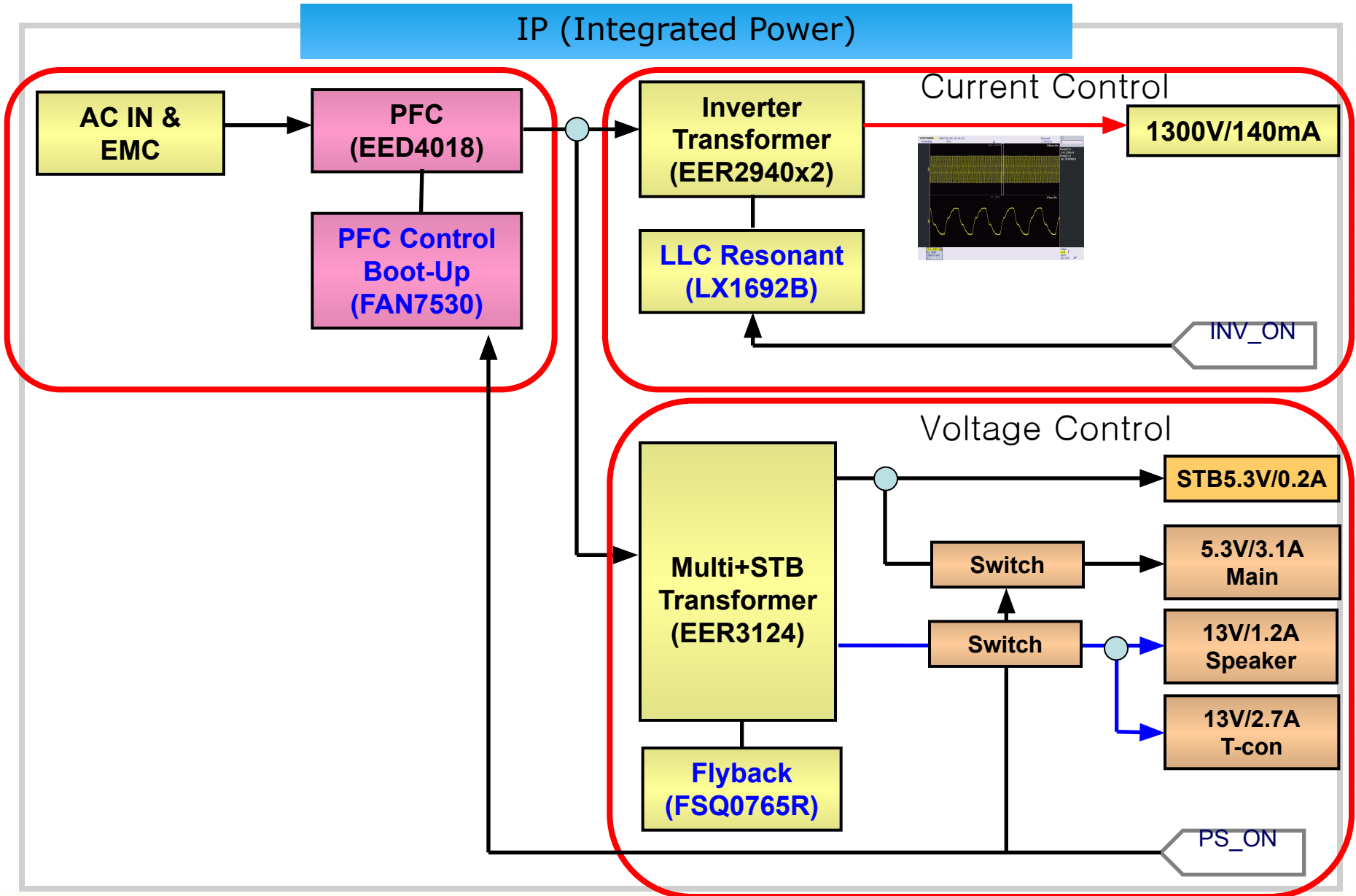

3. IP BOARD INPUT CHARACTERISTIC

3. INPUT CHARACTERISTICS

3.1 INPUT VOLTAGE RANGE: 90Vac TO 264Vac , SINGLE PHASE.

NORMAL VOLTAGE: 100-240Vac

3.2 INPUT FREQUENCY RANGE: 47Hz TO 63Hz.

NORMAL FREQUENCY: 50-60Hz

3.3 MAX INPUT AC CURRENT: 2.0Arms @90VAC.

3.4 INRUSH CURRENT: PEAK INRUSH CURRENT AT ANY ALLOWABLE OPERATING TEMPERATURE SHALL NOT OPEN LINE FUSE, RECIFIER DIODE OR CAUSE PERMANENT DAMAGE TO THE SUPPLY.

3.5 DPMS DISSIPATION: LESS THAN 0.9 WATT AT 5V/40mA, AT 230Vac/60Hz.

OR NO LOAD 0.5W MAX AT 230Vac/60Hz

4. POWER OUTPUT CHARACTERISTIC

4. POWER OUTPUT CHARACTERISTICS

4.1 . Power Output Voltage

Parameter	Min (Vrms)	NOM (Vrms)	Max (Vrms)
+13Vdc	12.5	13.0	13.2
+5.3Vdc	5.03	5.3	5.56
+5.3VSBdc	5.03	5.3	5.56

The output voltage is measured at the connector at the output end of the cable.

4.2 . Power Output Current

Parameter	Min (Arms)	NOM (Arms)	Max (Arms)
+13Vdc	0.2	-	1.6
+5.3Vdc	0.5	-	2
+5.3VSBdc	0.01	-	0.6

The minimum and maximum continuous output current are listed in this section

4. POWER OUTPUT CHARACTERISTIC

4-3. Output Ripple / Noise

Tested with 0.1 μ F and 47 μ F capacitance at output connector terminal for ripple and noise test.

Parameter	Ripple Voltage (mV p-p)
+13Vdc	300
+5.3Vdc	200
+5.3VSBdc	200

4.4. Output Over Voltage Protection

Parameter	V Max.
+13Vdc	17V
+5.3Vdc	8.5V
+5.3VSBdc	8.5V

4. POWER OUTPUT CHARACTERISTIC

4.5. Output Over Current Protection

Parameter	A Min.
+13Vdc	2.5A
+5.3Vdc	2.8A
+5.3VSBdc	1.5A

4.6. Output Power And Turn-on Delay

The turn-on delay from application of AC input power to the establishment of rated DC power voltage should not exceed 3 seconds@100Vac under any conditions at CC mode test .

4.7. Output Voltage Hold-up Time

When the power supply is operated at 100% of maximum continuous output load , the minimum output hold-up time after loss of input power shall be 20.0mS for AC input voltage (100Vac / 60Hz) and at 45-degrees cut angle

5. INVERTER OUTPUT CHARACTERISTIC

5. INVERTER OUTPUT CHARACTERISTICS

5.1. INVERTER INPUT CHARACTERISTICS

PARAMETER	SYMBOL	MIN.	NOM.	MAX	UNIT	REMARKS
Input Current	I _{in}	-	-	-	V	
Input Power	P _{in}	-	-	-	W	
ON/OFF Control Voltage	V _{on/off}	0	-	0.8	V	OFF STATE
		2.4	-	5.25	V	ON STATE

PARAMETER	SYMBOL	MIN.	NOM.	MAX	UNIT	REMARKS
PWM Frequency	EPWM	140	150	160	Hz	PWM FREQUENCY
PWM Signal Duty	EPWM	20	-	100	%	

5. INVERTER OUTPUT CHARACTERISTIC

5.2. INVERTER OUTPUT CHARACTERISTICS

PARAMETER	SYMBOL	MIN.	NOM.	MAX.	UNIT	REMARKS
Lamp Open Voltage	Vopen	1750	-	-	Vrms	EPWM=100%,All connector open@ 25°C
Ignition time	Ts	1	-	2	Vrms	EPWM=100%,All connector open@ 25°C
Lamp Current (max.)	Io(max)	7.5	8.0	8.5	mArms	EPWM=100%
Lamp Frequency	f	62	-	65	KHz	LOAD : PANEL

NOTE

- 1). All conditions are at 25°C ambient unless otherwise specified .
- 2). PANEL: NA

6. ENVIRONMENTAL CHARACTERISTIC

6. ENVIRONMENTAL CHARACTERISTIC

6.1 TEMPERATURE

Operating: 0 °C ~ 50°C
Storage: -20°C ~ +70°C

6.2 HUMIDITY

Operating: 10 ~ 90 % RH
Storage: 5 ~ 95 % RH

III. Board description

7. Power BOARD LAYOUT

19" SMPS Board

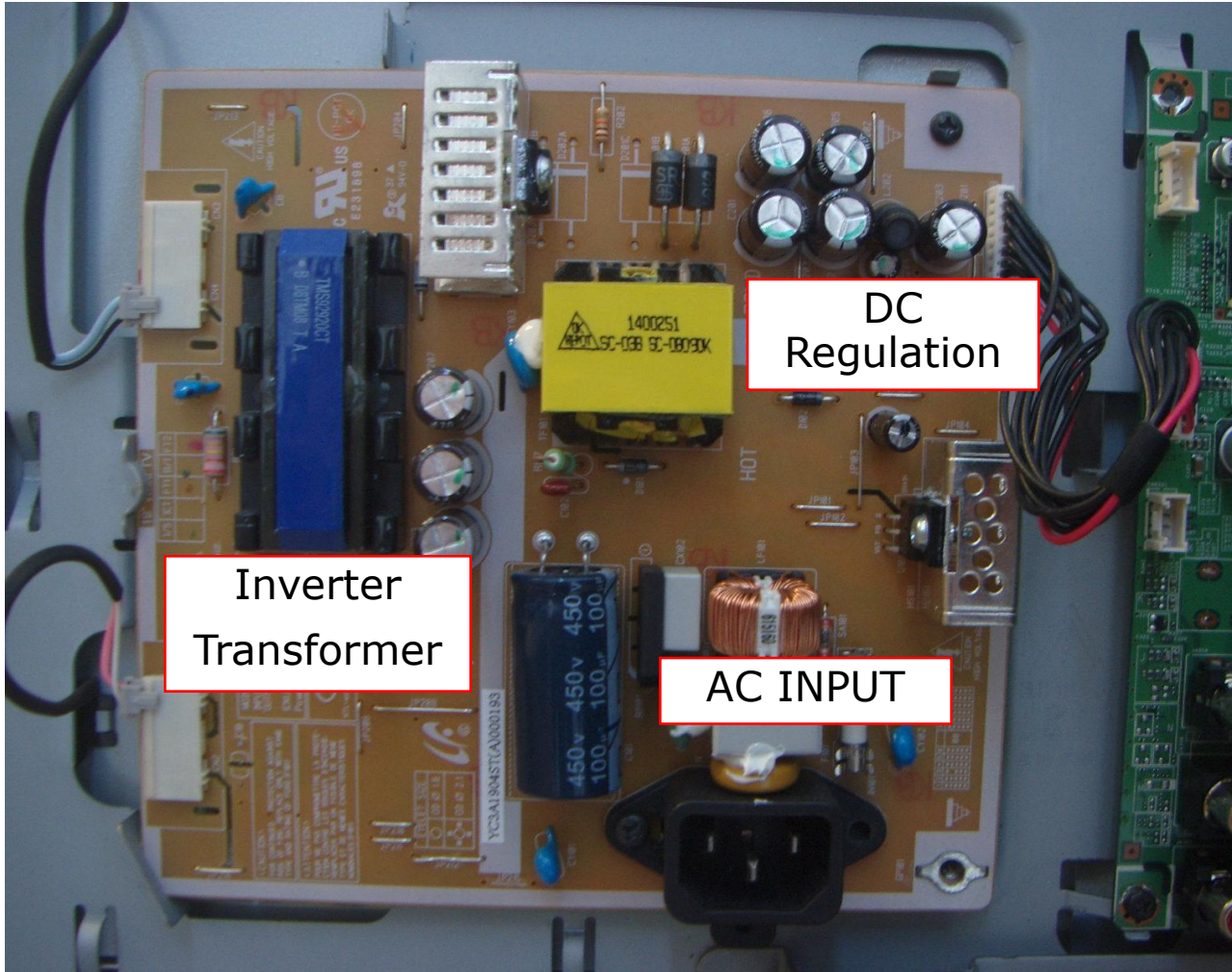

III. Board description

7. POWER BOARD LAYOUT

22" SMPS Board

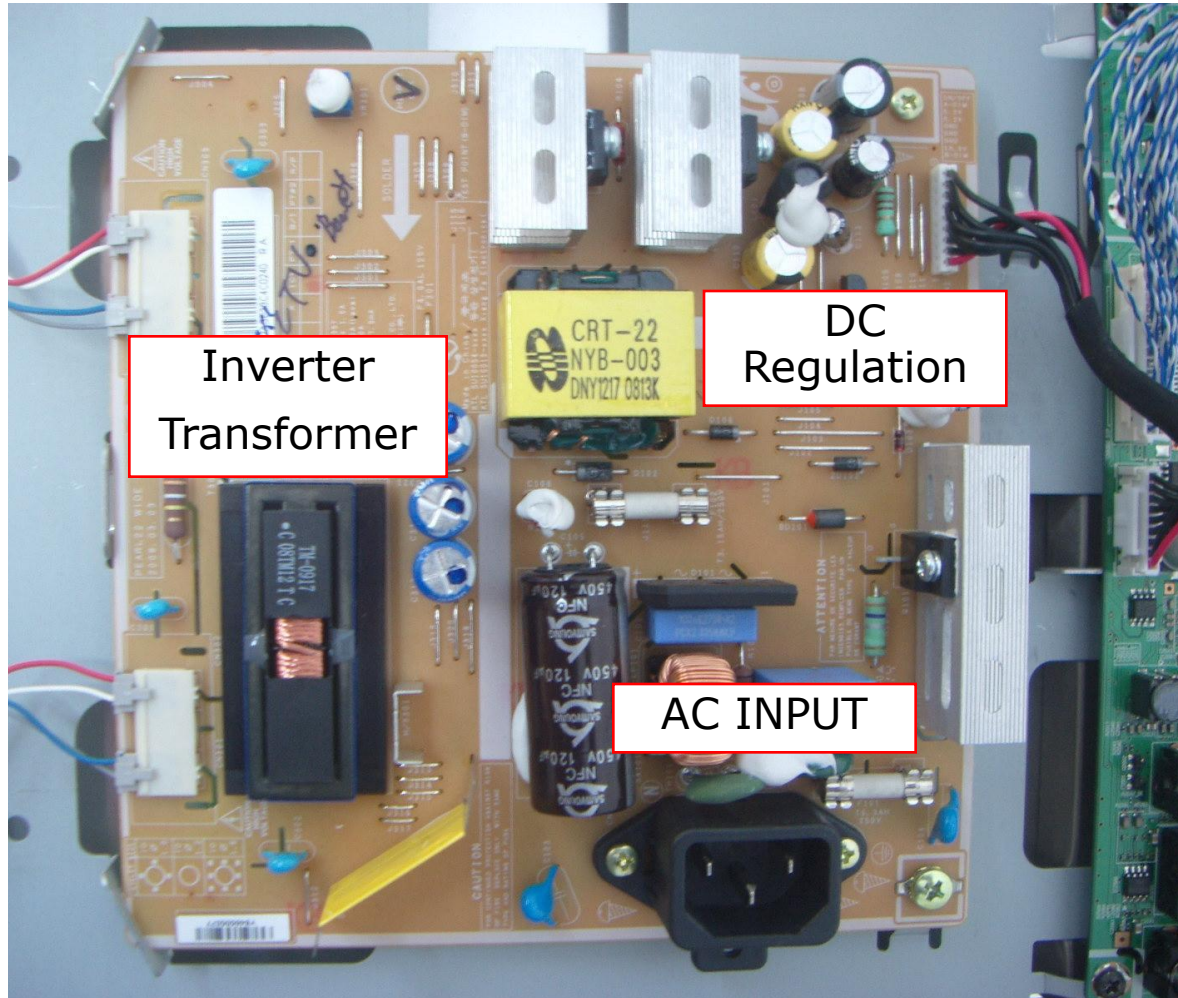

III. Board description

7. POWER BOARD LAYOUT

26" IP Board

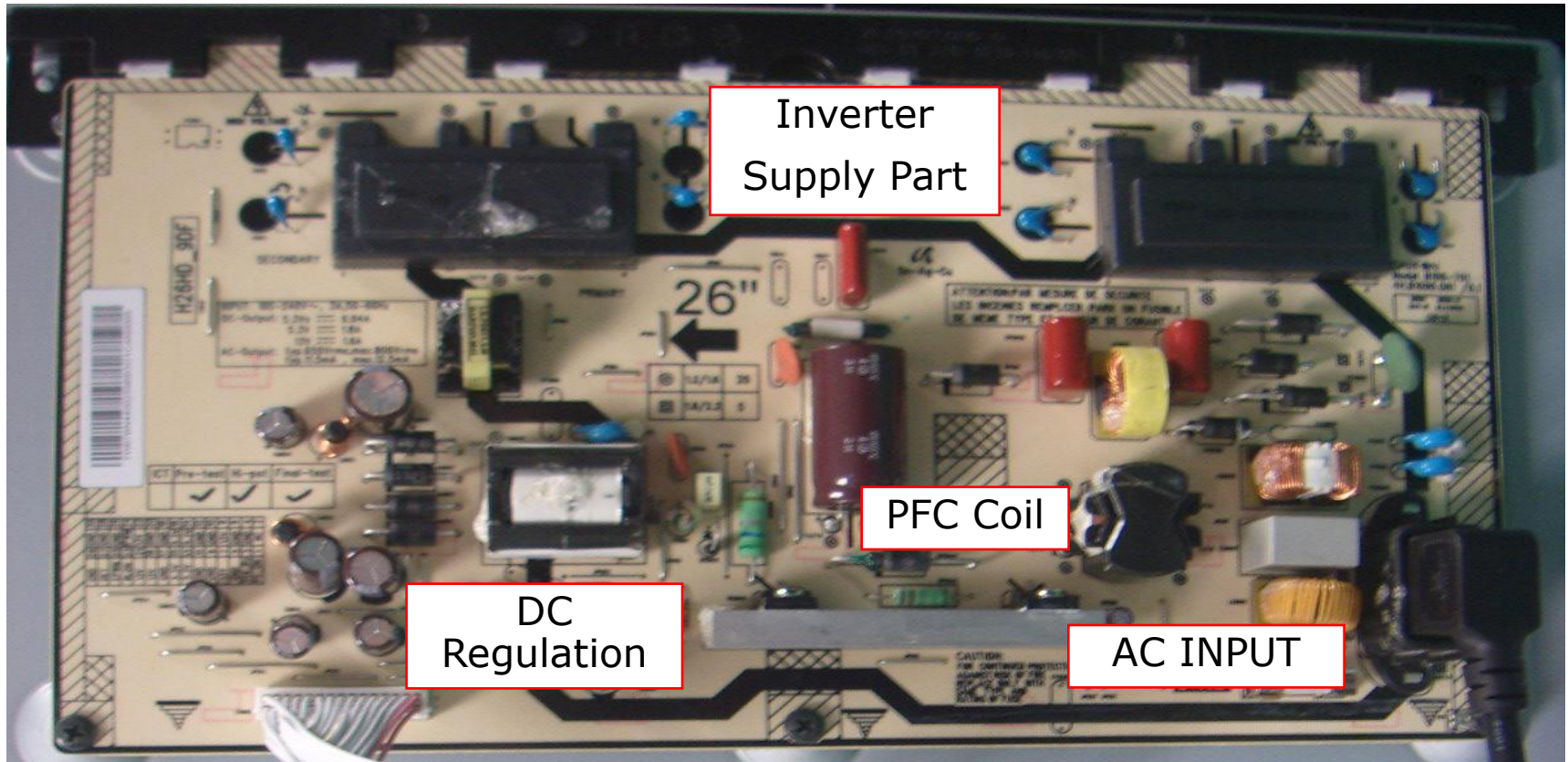

III. Board description

7. POWER BOARD LAYOUT

32" IP Board

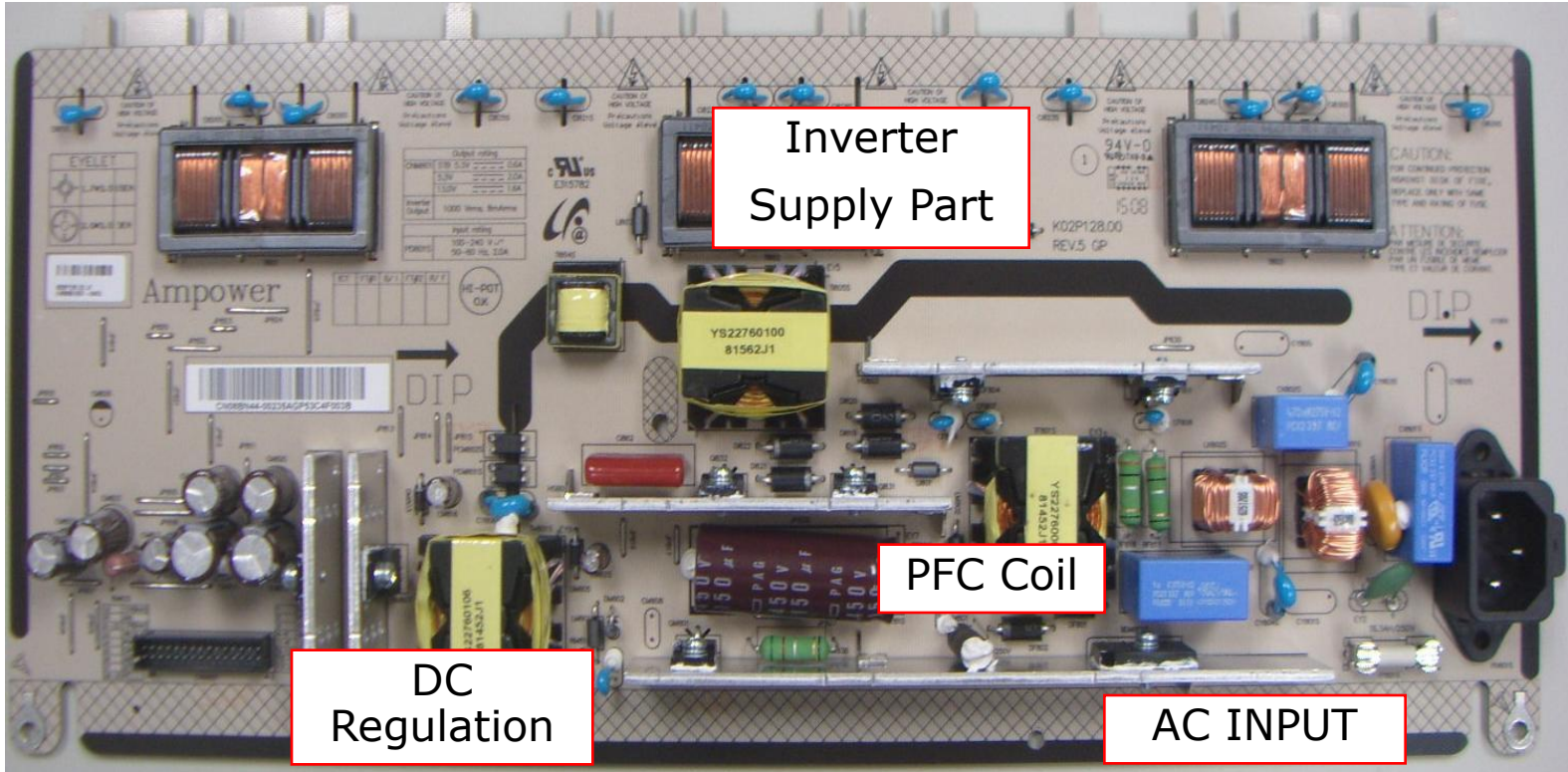

III. Board description

7. POWER BOARD LAYOUT

37" IP Board

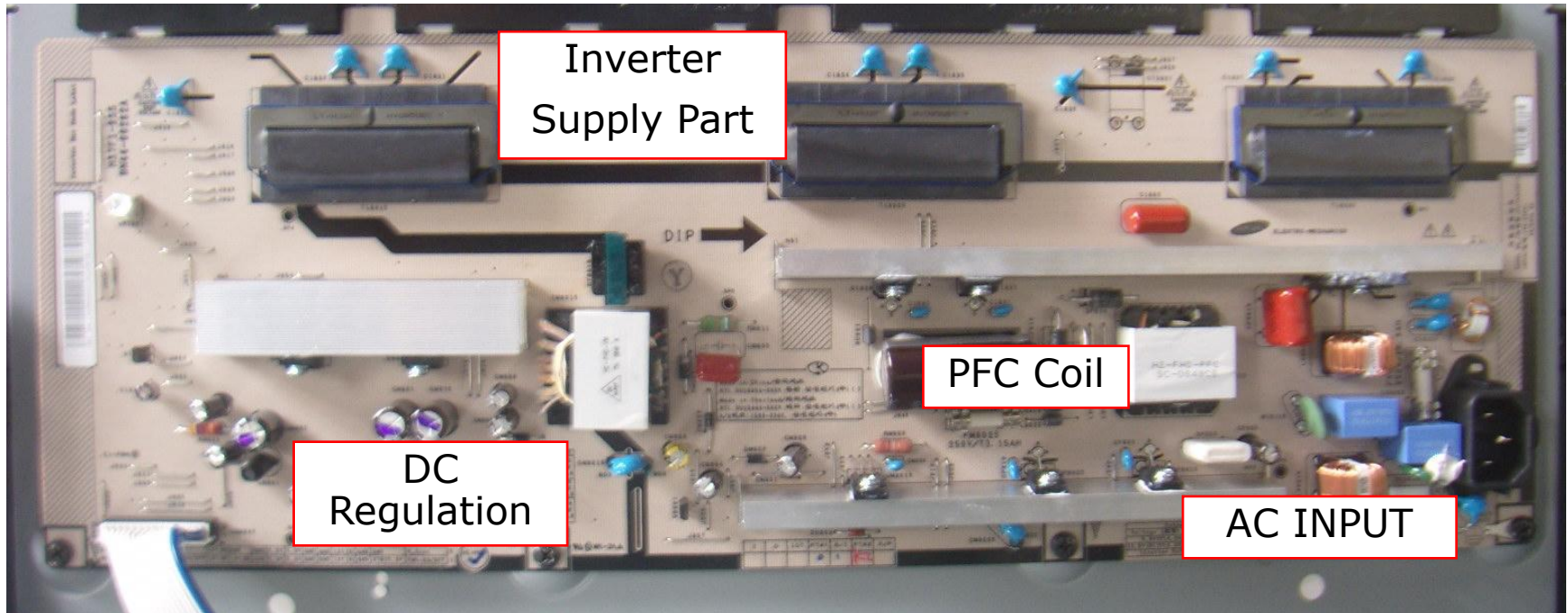

III. Board description

7. POWER BOARD LAYOUT

40" IP Board

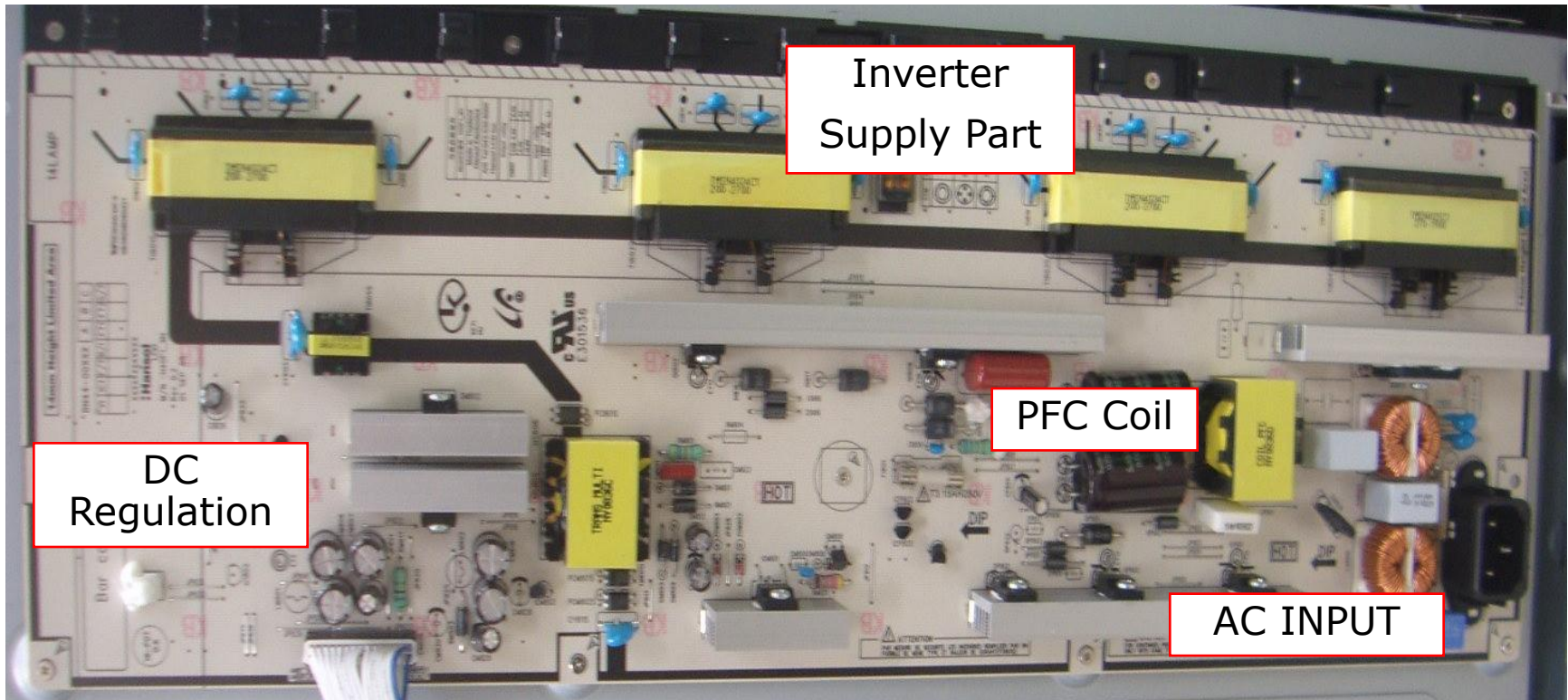

7. POWER BOARD LAYOUT

46" SMPS Board

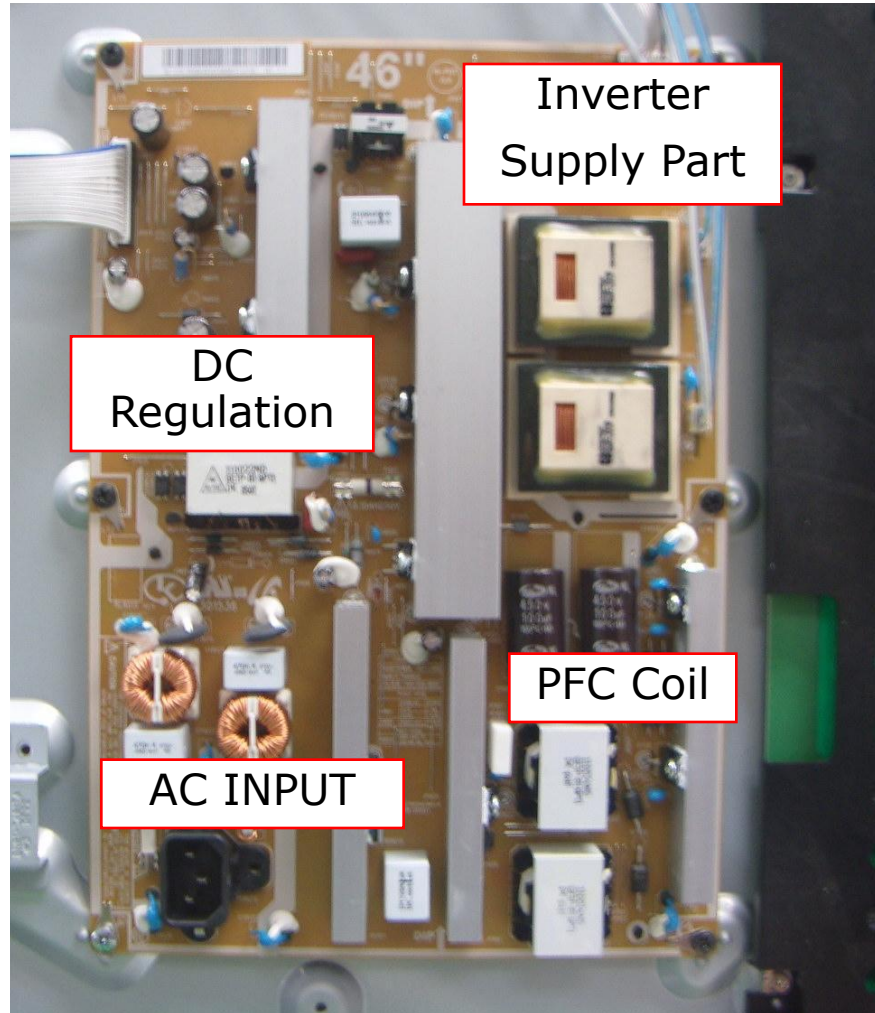

8. IP BOARD PIN CHARACTERISTIC

8. IP BOARD PIN CHARACTERISTICS

8.1 AC INPUT CONNECTOR [PD801S]

PD801S:DAC-11P (DONGIL)

PIN NUMBER	SYMBOL	REMARK
1	L	AC Input voltage
2	FG	GROUND
3	N	AC Input voltage

8. IP BOARD PIN CHARACTERISTIC

8.2 POWER OUTPUT CONNECOTR PIN ASSIGNMENT[CNM801]

CN802:SMW200-30C(YEONHO)

PIN NUMBER	SYMBOL	REMARK
1	POWER ON/OFF	POWER SUPPLY ON/OFF
2	H-Sync	NC
3	5VSB	
4,5,6	GND	
7,8	13V(Sound)	+13V DC OUTPUT
9,10,11,12	GND	
13,14,15,16	5.3V	+5.3V DC OUTPUT
17,18	GND	
19	13V(MAIN)	+13V DC OUTPUT
20	GND	
21,22	13V(MAIN)	+13V DC OUTPUT
23	Inverter ON/OFF	BLU ON/OFF
24	IPWM	NC
25	EPWM	20~100%
26	GND	S-GND
27	LAMP_DET	ERROR (Normal: Hi ; Abnormal :Low)
28,29,30	NC	NC

8. IP BOARD PIN CHARACTERISTIC

Test Condition of the circuit [Jig Test]

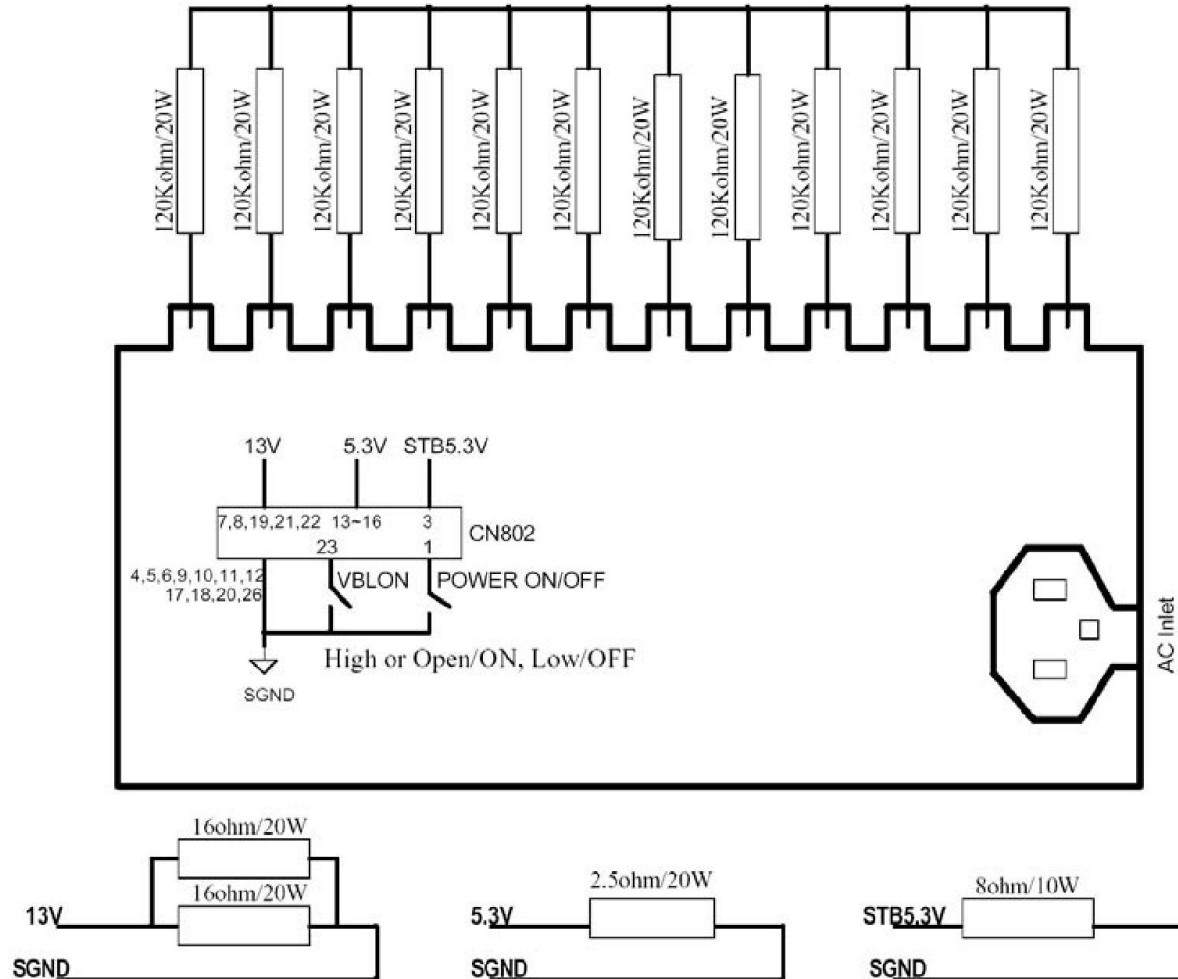

8. IP BOARD PIN CHARACTERISTIC

GENERAL REQUIREMENT OF WORLDWIDE STANDARD

1. MEET SAFETY REQUIRMENT.

UL60065, CSA C22.2 NO.60065, IEC 60065 FOR UL,CUL,CB,EK.

2. IMMUNITY TEST:(EN55024)











- IEC61000-4-2 ELECTROSTATIC DISCHARGE IMMUNITY TEST (ESD) Level 4 Criterion B
 - (1) AIR DISCHARGE TEST(WITH SYSTEM): $\pm 2KV$, $\pm 4KV$, $\pm 8KV$, $\pm 15KV$.
 - (2) CONTACT DISCHARGE TEST(WITH SYSTEM): $\pm 2KV$, $\pm 4KV$, $\pm 8KV$.
- IEC61000-4-3 Radio Frequency Electromagnetic Field Immunity Test (RS): Level 2, criterion A. (WITH SYSTEM)
- IEC61000-4-4 Electrical Fast Transient/Burst Immunity Test (EFT) Level 2:1KV/5KHz on AC power port for 1 minute, criterion B. (WITH SYSTEM)
- IEC61000-4-5 Surge Immunity Test (PLD):(WITH SYSTEM)
 - (1) L to N:1.0KV/1.2*50uS, criterion B.
 - (2) L/N to FG:2.0KV/1.2*50uS, criterion B.
- IEC61000-4-6 Conducted Disturbances Induced by Radio-Frequency Field Immunity Test (CS):Level 2 criterion A. (WITH SYSTEM)
- IEC61000-4-11 Voltage Dips and Voltage Interruptions Immunity Test:
 - (1) Criterion B for > 95%, 0.5period Voltage Dips.
 - (2) Criterion C for > 30%, 25period Voltage Dips;> 95%, 250period Voltage Interruptions.



IV. Disassembly

Description	Picture Description	Screws
<p>1. Place the TV face down on cushioned table. Remove 4 screws from the Stand. Remove stand.</p>	 A photograph showing the back of a television set. The stand is attached to the bottom of the TV. The TV is placed on a light-colored surface.	
	 A close-up photograph of the back of the TV. Four screws are circled in red, indicating their locations for removal. A label with a barcode is visible at the top.	 
	 A close-up photograph showing a hand holding the stand. A red arrow points to the bottom of the stand, indicating the point of removal from the TV's back panel.	

IV. Disassembly

Description	Picture Description	Screws
<p>2. Remove the 11 screws of rear-cover. (32" - 10, 37" - 13, 46" - 14)</p>		 
<p>3. Lift up the rear-cover.</p>		
<p>4. Remove the left and right speaker.</p>		
<p>5. Remove the 4 screws of main board and 8 screws of IP board. (main board : 32"/37"/46" - 4 IP board : 32"/37" - 5, 46" - 7)</p>		   

IV. Disassembly

Description	Picture Description	Screws
<p>6. Remove the 2 screws of bracket TOP. Remove the 8 screws of bracket stand link. (TOP : 32"/37"/46" - 2, Stand link : 32" - 7, 37"/46" - 8)</p>		   
<p>7. Lift up the bracket TOP and stand link.</p>		

IV. Disassembly

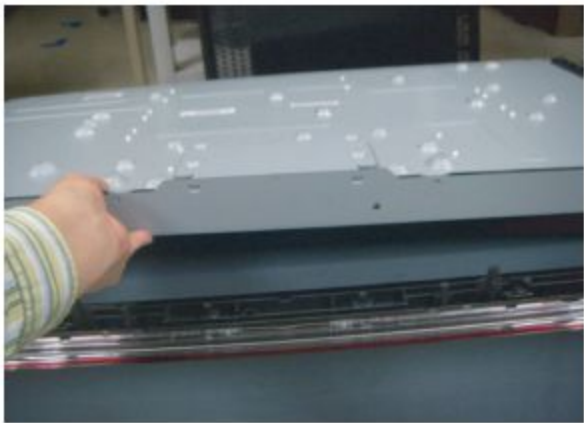
Description	Picture Description	Screws
8. Lift up the panel.	 A close-up photograph showing a person's hand, wearing a striped sleeve, lifting a white, rectangular panel from a dark-colored device. The panel has several small, circular indentations or screws on its surface. The device below the panel appears to be a laptop or a similar electronic device with a dark chassis.	

※ Reassembly procedures are in the reverse order of disassembly procedures.

CONTENTS

- I. Power Trouble Shooting
- II. Analog Part
- III. Digital Part
- IV. Sound Part
- V. Flow Chart & Waveforms
- VI. White Balance

A) Power Trouble Shooting

- Power part is composed of power board and main board (small power)
- Check connectors between power board and main board
- Check main board power output on the board
- When you check main board power (small power IC), There are two types of power IC. One is PWM type, another is regulator type. PWM type should check after inductor. Regulator type should check on the output pin.
- Check each Voltage output

Check After Inductor

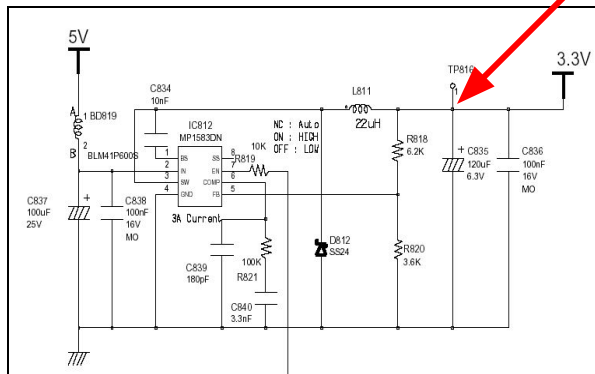

1 PWM Type

Check On Pin

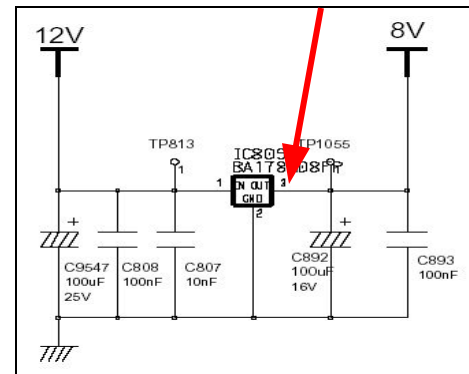

2 Regulator Type

B) Analog Part

- It is easy to check analog video signal than digital video signal
- Use reference signal input (EX. 16 Gray)
- Check Signal Level and sync
- Check Signal path until input of Video decoder
(Tuner → Switch → Video Decoder, AV Connector → Switch → Video Decoder, Scart → Switch → Video Decoder)

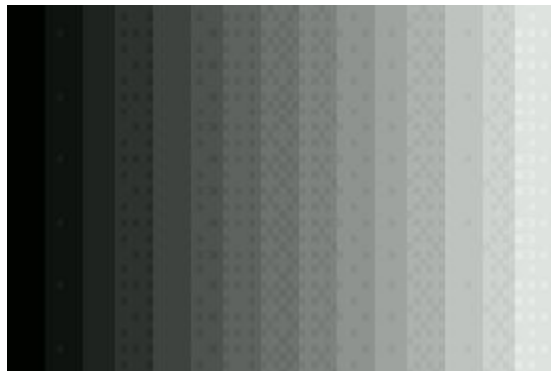

16 Gray Patten

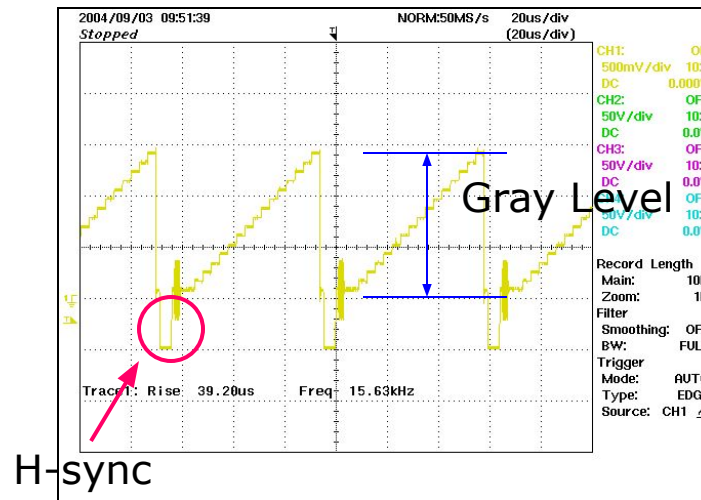

16 Gray Wave Form

C) Digital Part

- It is difficult to check digital video signal because of too fast and small signal
- Check digital video signal, Use H-sync, V-sync and Clock for basic
- Each digital video ICs connected with data line, H-sync, V-sync and Clock line
- Check H-sync period, V-sync period, Clock period
- If period is out of spec, Change the IC

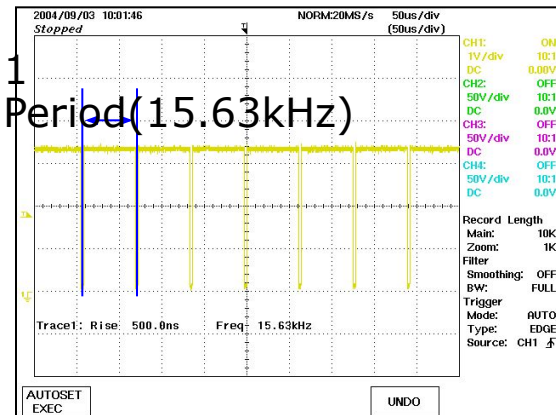

H-Sync

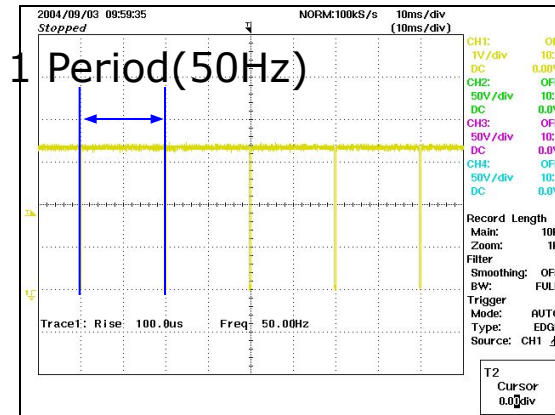

V-Sync

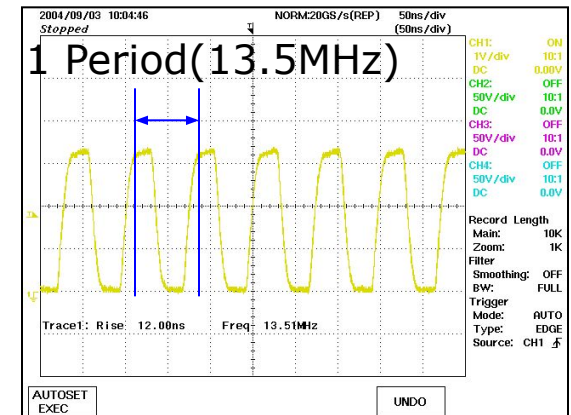

Clock

This example is Normal PAL TV signal Sync and Clock

D) Sound Part

- Sound block of SEMS12 is composed of Sound Processor, AMP, Speakers.
- If there is no sound or sound noise ,Trace the sound path
(Input → Sound Processor → AMP → Speaker)

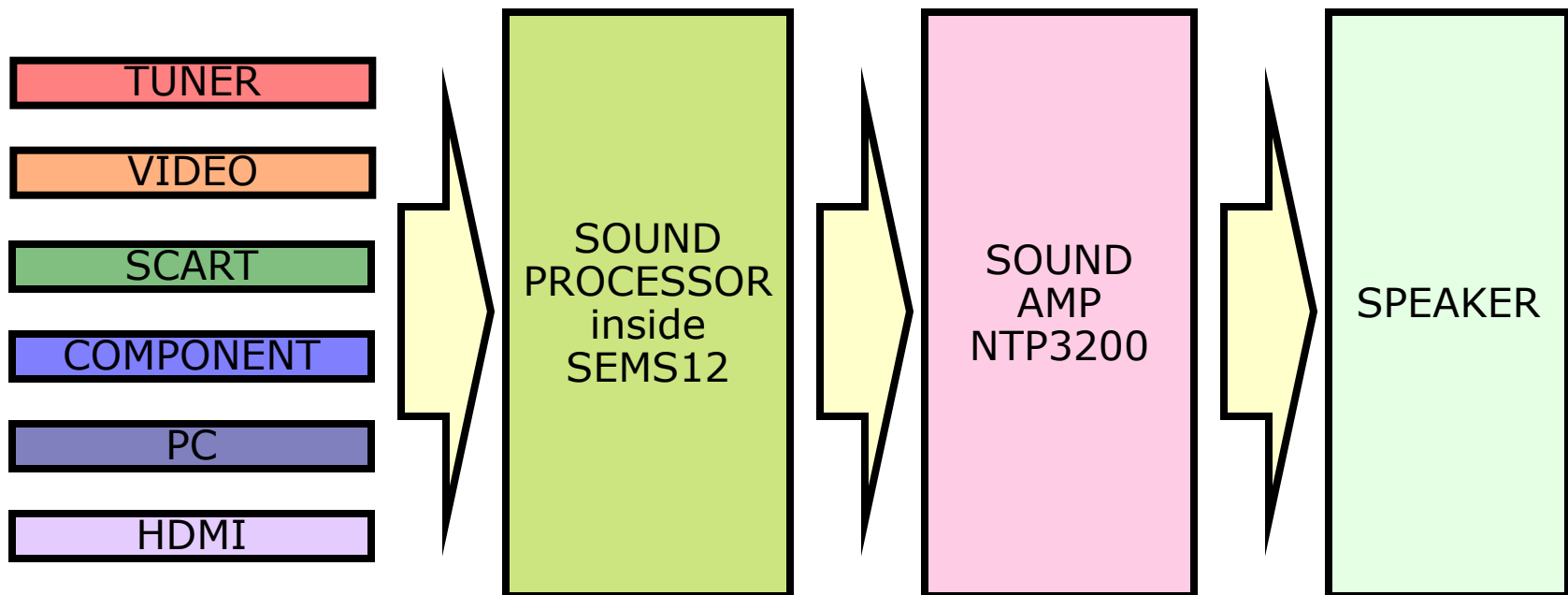

V. Trouble Shooting

4-1-2. No Power

Symptom	<ul style="list-style-type: none"> - The LEDs on the front panel do not work when connecting the power cord. - The SMPS relay does not work when connecting the power cord. - The units appears to be dead.
Major checkpoints	<p>The IP relay or the LEDs on the front panel does not work when connecting the power cord if the cables are improperly connected or the Main Board or SMPS is not functioning. In this case, check the following:</p> <ul style="list-style-type: none"> - Check the internal cable connection status inside the unit. - Check the fuses of each part. - Check the output voltage of SMPS. - Replace the Main Board.
Diagnostics	 <pre> graph TD Q1[Lamp(Backlight) Off, power indicator LED on?] -- No --> A1[Change the 30P power cable or IP board] Q1 -- Yes --> Q2[Does proper Stand-By DC A5V_PW appear at TP2004?] Q2 -- No --> A2[Change the Main Assy] Q2 -- Yes --> Q3[Does proper Main B12VS_PW, B13V_PW, B5V_PW appear at TP2007-8, TP2020-2, TP2013-6?] Q3 -- No --> A2 Q3 -- Yes --> Q4[Does proper A3.3V_PW appear at R2028?] Q4 -- No --> A2 Q4 -- Yes --> Q5[Does proper B3.3V_PW, B1.9V_PW, B1.25V_PW appear at C2607, C2590, C2105?] Q5 -- No --> A2 Q5 -- Yes --> Q6[Does proper PANEL_VCC_PW appear at LVDS connector Pin #1-5 of T-con b'd?] Q6 -- No --> A3[Change the LVDS cable] Q6 -- Yes --> Q7[Does proper DC B12V appear at F1 of T-con b'd?] Q7 -- No --> A4[Change the T-con b'd] Q7 -- Yes --> Q8[A power is supplied to set?] Q8 -- No --> A5[Check a other function (No picture part) Replace a LCD Panel] </pre>
Caution	Make sure to disconnect the power before working on the IP board.

V. Trouble Shooting

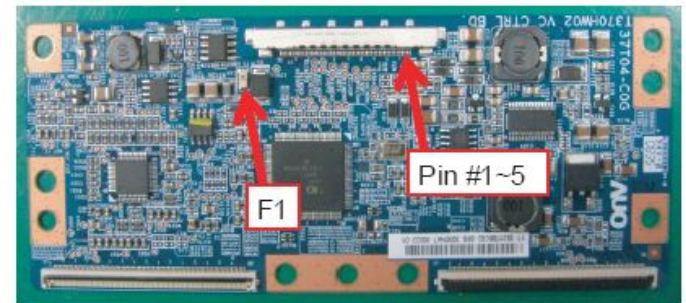
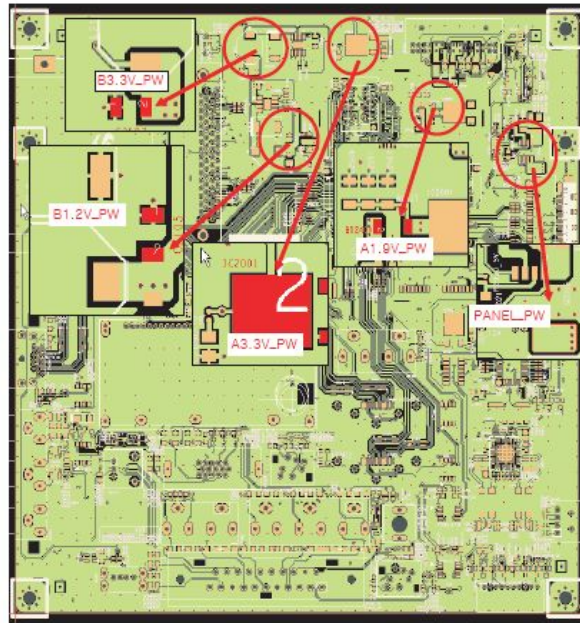
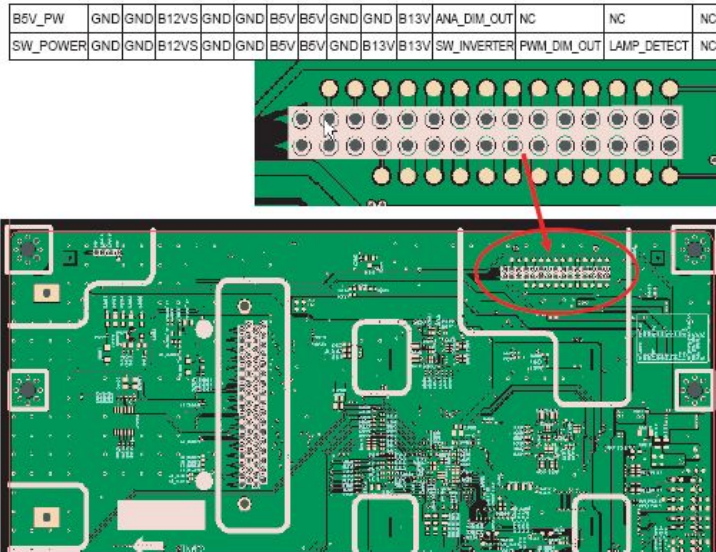

4-1-3. No Video (Analog PC signal)

Symptom	<ul style="list-style-type: none"> - Audio is normal but no picture is displayed on the screen.
Major checkpoints	<ul style="list-style-type: none"> - Check the PC source - Check the Arsenal, Check the Chelsea. - This may happen when the LVDS cable connecting the Main Board and the Panel is disconnected.
Diagnostics	 <pre> graph TD A[Power indicator LED is off. Lamp(Backlight) on, no video] -- No --> B[Check a set in the 'Stand-by mode' or 'DPMS mode'] A -- Yes --> C[Check the PC source and check the connection of D-SUB] C -- No --> D[Input the analog PC signal properly.] C -- Yes --> E{1 Does the signal appear at TP5002, 5003, 5004, 5006, 5008?} E -- No --> F[Check CN5001, PC cable. Change the Main Assy] E -- Yes --> G{2 Does the digital data appear at Pin #19,20,34,35 (LVDS Data clk) of LVDS connector?} G -- No --> H[Check IC4010 (Saturn4) Change the Main Assy] G -- Yes --> I[Check the LVDS cable? Check the T-Con B'd? Replace the LCD panel?] I -- No --> J[Please, Contact Tech support.] </pre>
Caution	Make sure to disconnect the power before working on the IP board.

V. Trouble Shooting

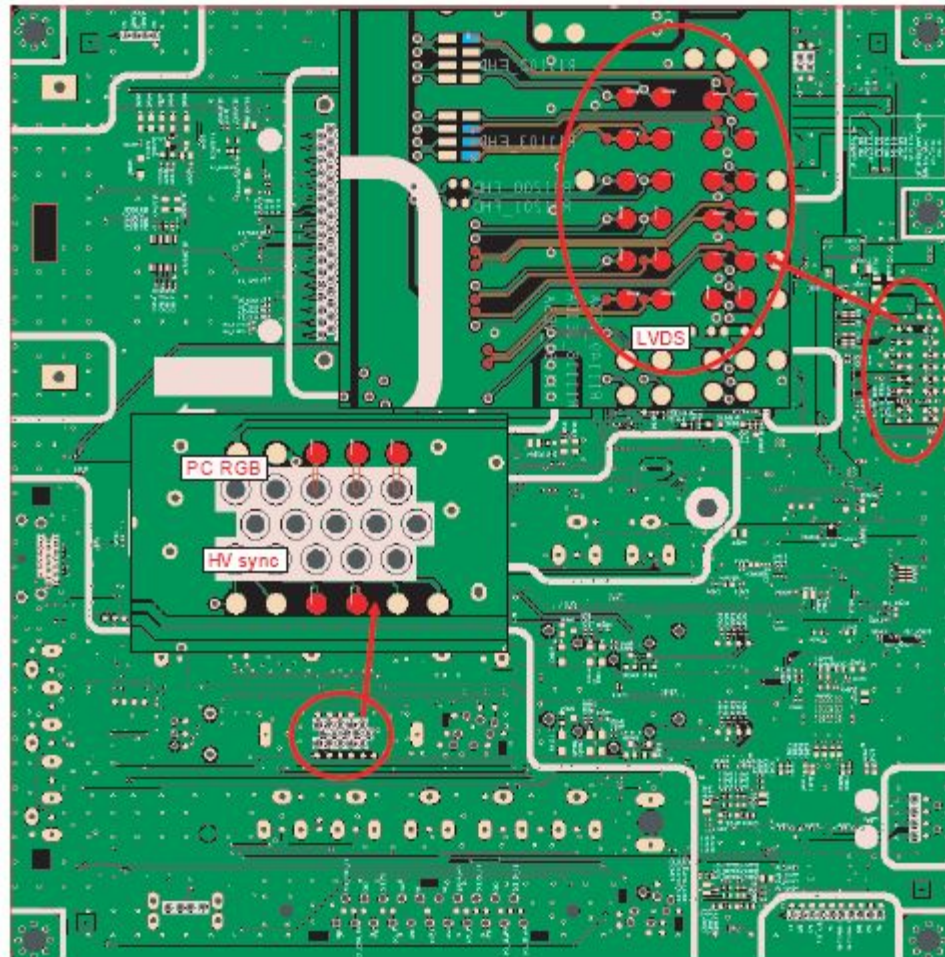

WAVEFORMS

1 PC input (V-sink , H-sink , R/G/B)

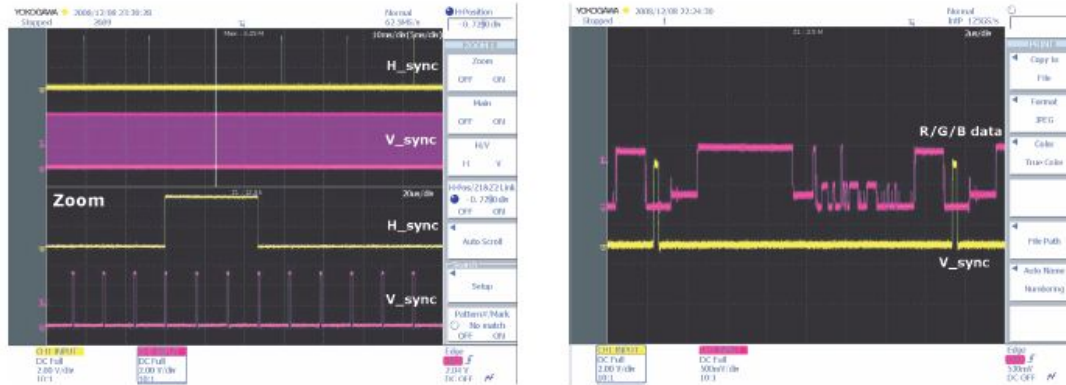

2 LVDS output

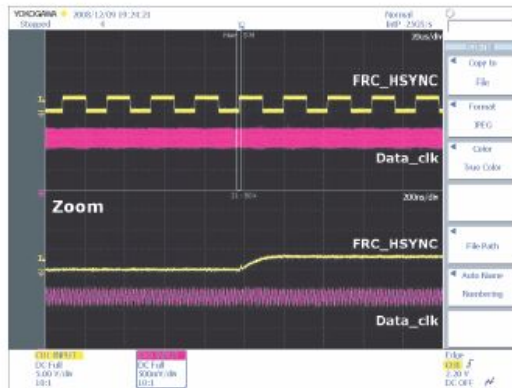

4-1-5. No Video (Tuner_CVBS)

Symptom	- Audio is normal but no picture is displayed on the screen.
Major checkpoints	<ul style="list-style-type: none"> - Check the Tuner CVBS source. - Check the Tuner, Check the Chelsea. - This may happen when the LVDS cable connecting the Main Board and the Panel is disconnected.
Diagnostics	 <pre> graph TD Q1[Power indicator LED is off. Lamp(Backlight) on, no video?] -- No --> A1[Check a set in the 'Stand-by mode'.'] Q1 -- Yes --> Q2[Check the RF source and check the connection of RF cable?] Q2 -- No --> A2[Input the RF source properly.] Q2 -- Yes --> Q3[Does the DC TU5V_PW, TU33V_PW appear at #3, #5 Pin of Tuner?] Q3 -- No --> A3[Change the Main Assy] Q3 -- Yes --> Q4[4 Does the CVBS data appear at #9 pin of Tuner?] Q4 -- No --> A4[Check Tuner Change the Main Assy] Q4 -- Yes --> Q5[2 Does the digital data appear at Pin #19,20,34,35 (LVDS Data clk) of LVDS connector?] Q5 -- No --> A5[Check IC4010 (Saturn4) Change the Main Assy] Q5 -- Yes --> Q6[Check the LVDS cable? Check the T-Con B'd? Replace the LCD panel?] Q6 -- No --> A6[Please, Contact Tech support] </pre>
Caution	Make sure to disconnect the power before working on the IP board.

V. Trouble Shooting

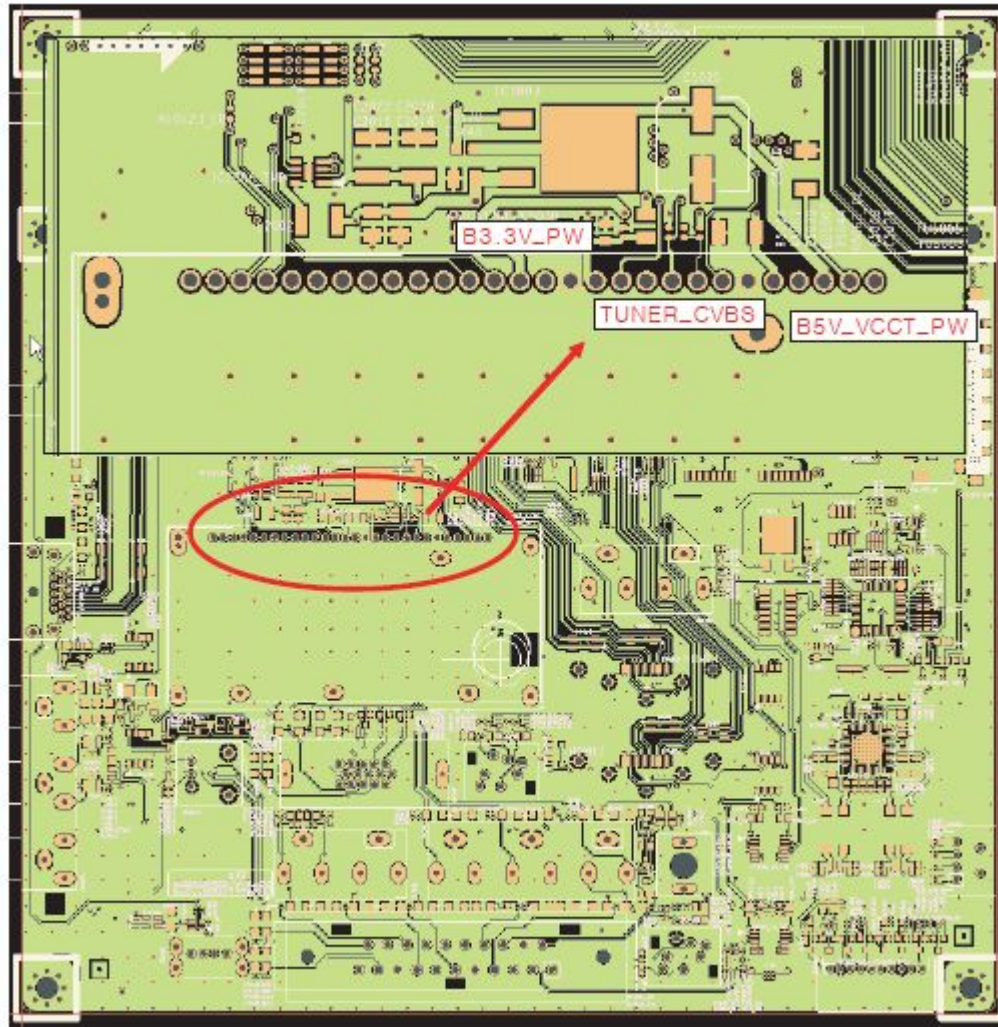

WAVEFORMS

4 CVBS OUT (Grey Bar)

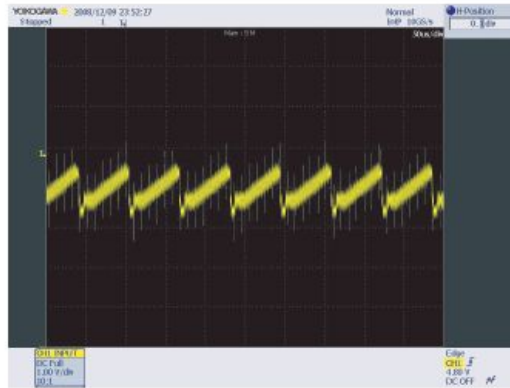

2 LVDS output

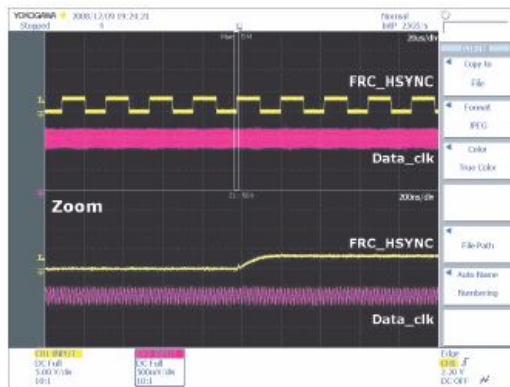

4-1-6. No Video (Tuner DTV)

Symptom	<ul style="list-style-type: none"> - Audio is normal but no picture is displayed on the screen.
Major checkpoints	<ul style="list-style-type: none"> - Check the DTV source. - Check the Tuner, Check the Chelsea. - This may happen when the LVDS cable connecting the Main Board and the Panel is disconnected.
Diagnostics	<div style="text-align: center;">  </div> <pre> graph TD Q1[Power indicator LED is off. Lamp(Backlight) on, no video] -- No --> A1[Check a set in the 'Stand-by mode'.] Q1 -- Yes --> Q2[Check the connection of RF cable] Q2 -- No --> A2[Input the RF cable properly.] Q2 -- Yes --> Q3[Check the 'signal strength' in Self Diagnosis menu Strength is enough?] Q3 -- No --> A3[Check the D-TV source.] Q3 -- Yes --> Q4[Does the DC B5V_VGCT_PW, B1.25VT_PW, B3.3V_PW appear at #3, #15, #12 Pin of Tuner?] Q4 -- No --> A4[Change the Main Assy] Q4 -- Yes --> Q5[Does the digital data appear at Pin #19,20,34,35 (LVDS Data clk) of LVDS connector?] Q5 -- No --> A5[Check IC4010 (Saturn4) Change the Main Assy] Q5 -- Yes --> Q6[Check the LVDS cable? Check the T-Con B'd? Replace the LCD panel?] Q6 -- No --> A6[Please, Contact Tech support] </pre>
Caution	<p>Make sure to disconnect the power before working on the IP board.</p>

V. Trouble Shooting

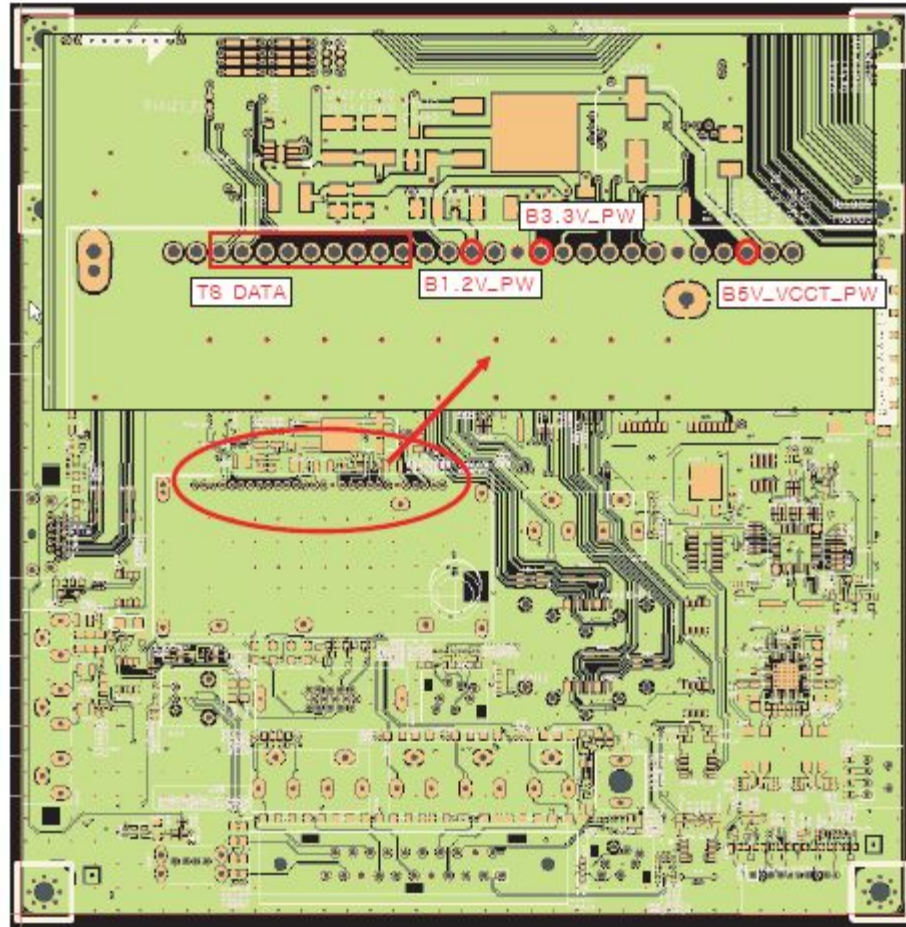

WAVEFORMS

2

LVDS output

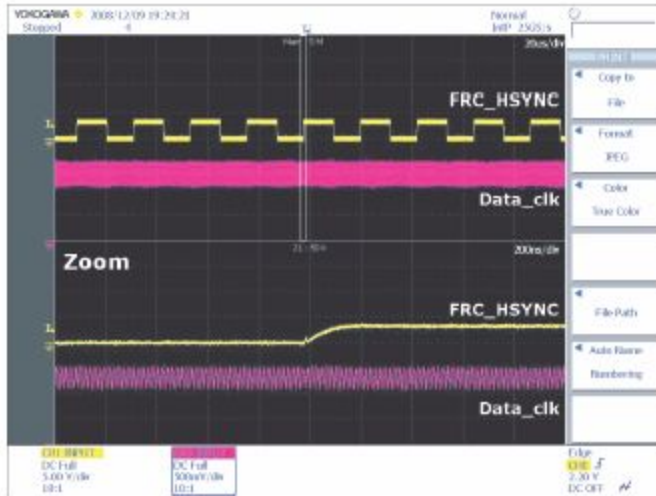

4-1-7. No Video (Video CVBS)

Symptom	<ul style="list-style-type: none"> - Audio is normal but no picture is displayed on the screen.
Major checkpoints	<ul style="list-style-type: none"> - Check the Video CVBS source - Check the Chelsea. - This may happen when the LVDS cable connecting the Main Board and the Panel is disconnected.
Diagnostics	 <pre> graph TD Q1[Power indicator LED is off. Lamp(Backlight) on, no video?] -- No --> A1[Check a set in the 'Stand-by mode'.] Q1 -- Yes --> Q2[Check the video source and check the connection of video cable?] Q2 -- No --> A2[Input the video source properly.] Q2 -- Yes --> Q3[4 Does the CVBS data appear at TP - 7045?] Q3 -- No --> A3[Check CN7005 Change the Main Assy] Q3 -- Yes --> Q4[2 Does the digital data appear at Pin #19,20,34,35 (LVDS Data clk) of LVDS connector?] Q4 -- No --> A4[Check IC4010 (Saturn4) Change the Main Assy] Q4 -- Yes --> Q5[Check the LVDS cable? Check the T-Con B'd? Replace the LCD panel?] Q5 -- No --> A5[Please, Contact Tech support] </pre>
Caution	<p>Make sure to disconnect the power before working on the IP board.</p>

V. Trouble Shooting

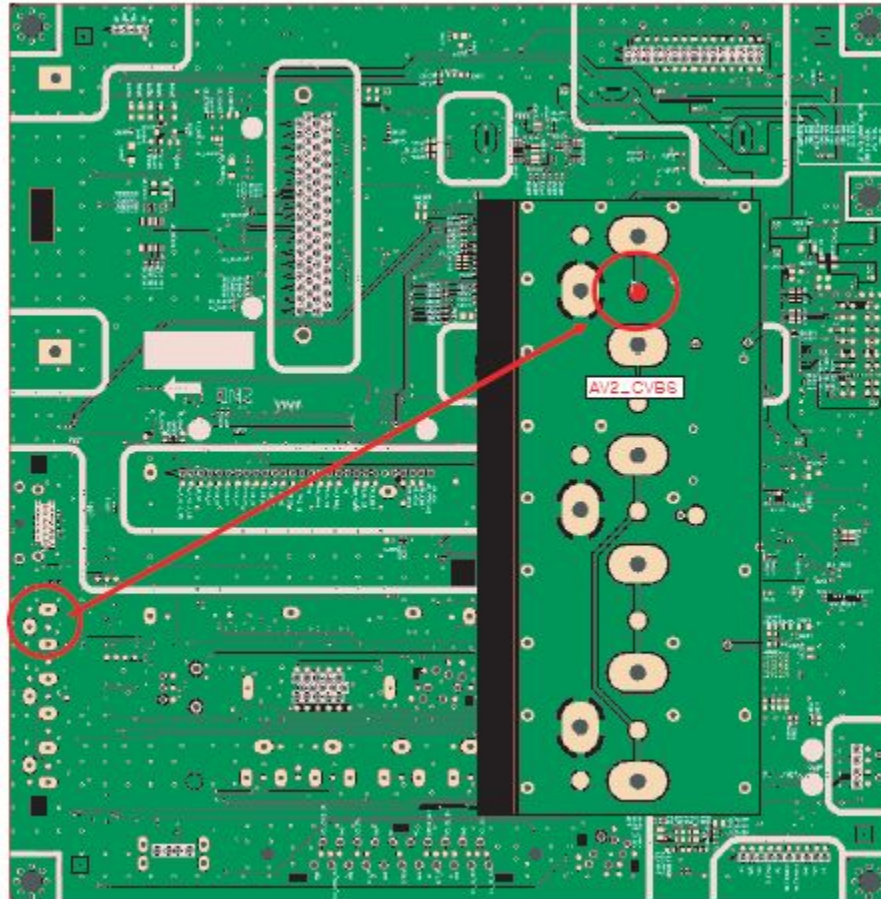

WAVEFORMS

4 CVBS OUT (Grey Bar)

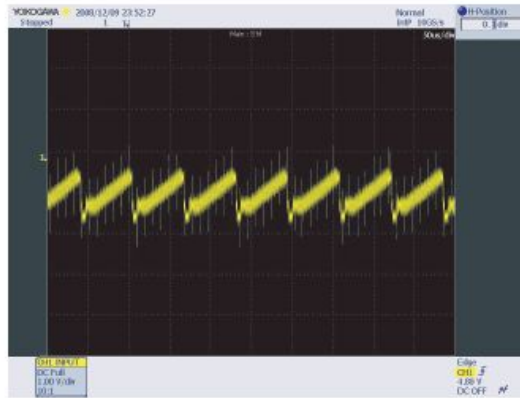

2 LVDS output

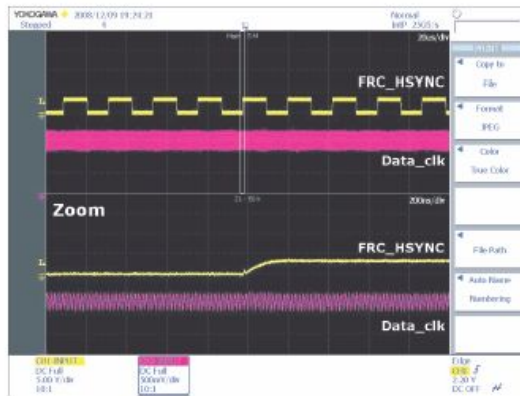

4-1-8. No Video (Component)

Symptom	<ul style="list-style-type: none"> - Audio is normal but no picture is displayed on the screen.
Major checkpoints	<ul style="list-style-type: none"> - Check the Component source - Check the chelsea. - This may happen when the LVDS cable connecting the Main Board and the Panel is disconnected.
Diagnostics	 <pre> graph TD Q1[Power indicator LED is off. Lamp(Backlight) on, no video?] -- No --> A1[Check a set in the 'Stand-by mode'.'] Q1 -- Yes --> Q2[Check the component source and check the connection of component cables(Y,Pb,Pr)?] Q2 -- No --> A2[Input the component source properly.] Q2 -- Yes --> Q3[6 Does the component data appear at TP - 5100, 5024, 5025 (Comp1 / Y, Pb, Pr)?] Q3 -- No --> A3[Check CN5003 Change the Main Assy] Q3 -- Yes --> Q4[2 Does the digital data appear at Pin #19,20,34,35 (LVDS Data clk) of LVDS connector?] Q4 -- No --> A4[Check IC4010 (Saturn4) Change the Main Assy] Q4 -- Yes --> Q5[Check the LVDS cable? Check the T-Con B'd? Replace the LCD panel?] Q5 -- No --> A5[Please, Contact Tech support] </pre>
Caution	<p>Make sure to disconnect the power before working on the IP board.</p>

V. Trouble Shooting

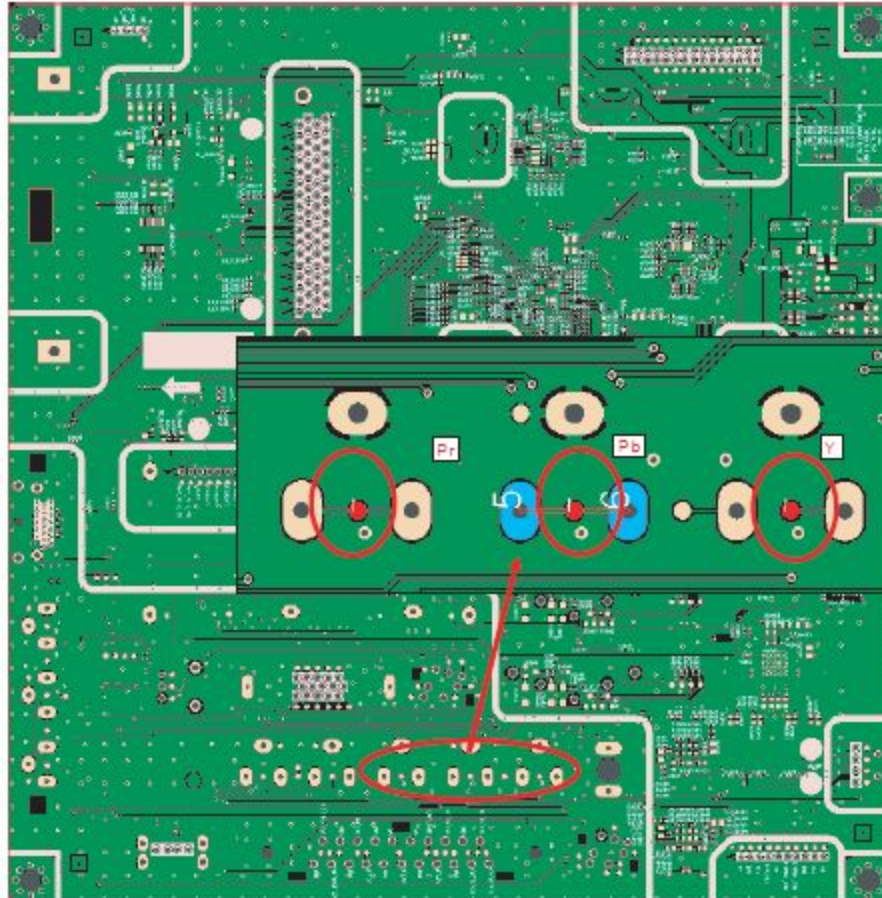

WAVEFORMS

5 Component_Y (Gray scale) / Pb / Pr (Color bar)

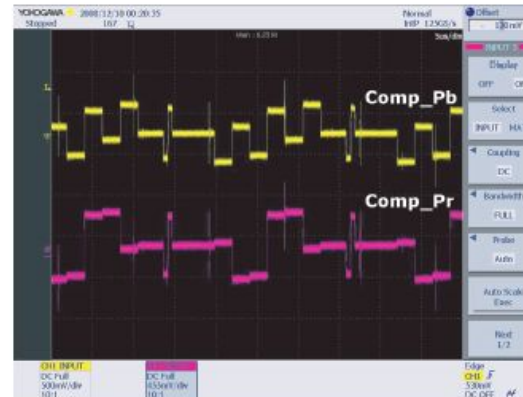
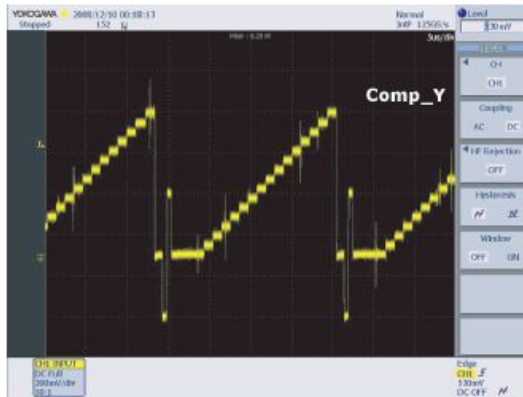

2 LVDS output

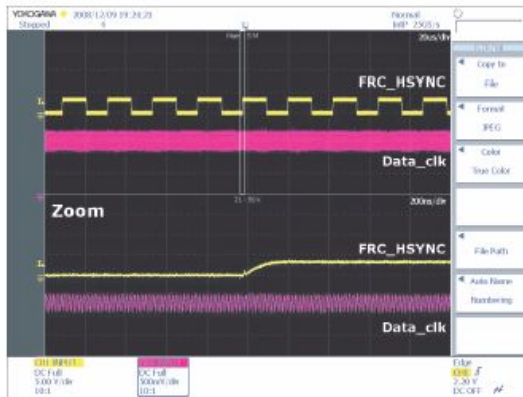

V. Trouble Shooting

4-1-9. No Sound

Symptom	- Video is normal but there is no sound..
Major checkpoints	<ul style="list-style-type: none"> - When the speaker connectors are disconnected or damaged. - When the sound processing part of the Main Board is not functioning. - Speaker defect..
Diagnostics	 <pre> graph TD A[Check the source and check the connection of sound cable (Comp/PC/DVI to HDMI).] -- No --> B[Input the sound source properly.] A -- Yes --> C[Does the sound data appear at CN5002(COMP), CN5011(PC, DVI), CN7005(AV), JA3201_EU(SCART)?] C -- No --> D[Check CN5002(COMP), CN5011(PC, DVI), CN7005(AV), JA3201_EU(SCART) Change the Main Assy] C -- Yes --> E[Does the B12VS_PW appear at TP2007-8?] E -- No --> F[Change the Main Assy] E -- Yes --> G[Does the sound data appear at TP - L-, L+, R-, R+?] G -- No --> H[Check IC4010 (Saturn4) Check IC9002 (Sound AMP) Change the Main Assy] G -- Yes --> I[Replace speaker] I -- No --> J[Please, Contact Tech support] </pre>
Caution	Make sure to disconnect the power before working on the IP board.

V. Trouble Shooting

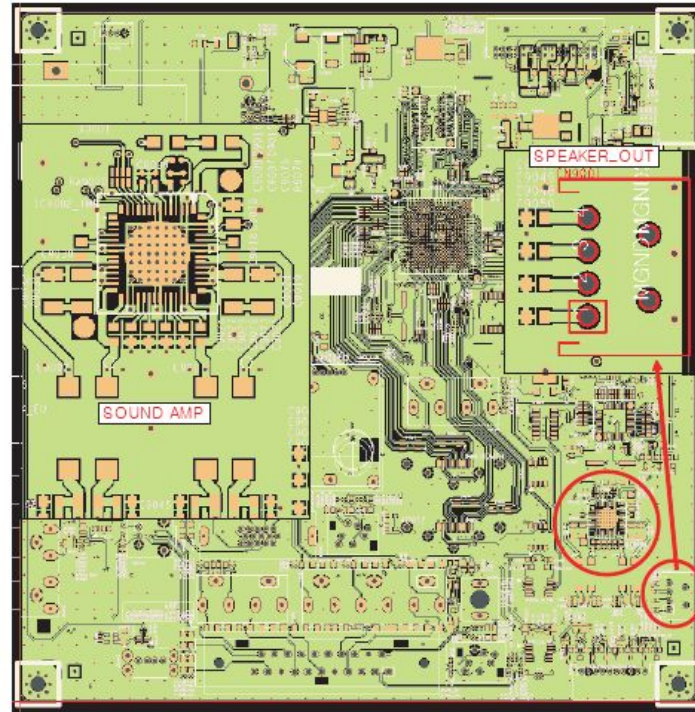
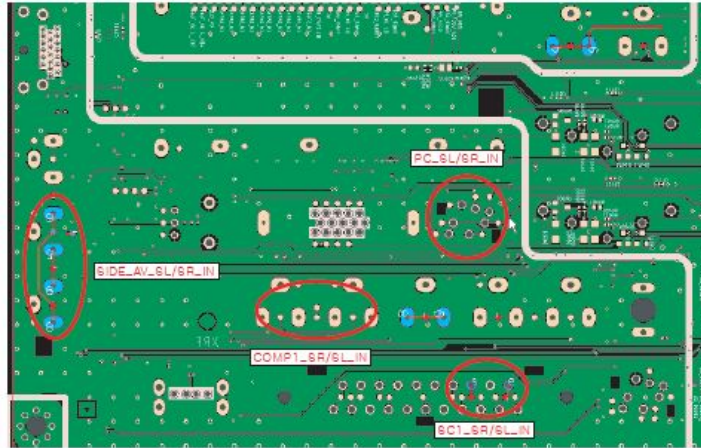

6 I2C Data



7 Speaker out

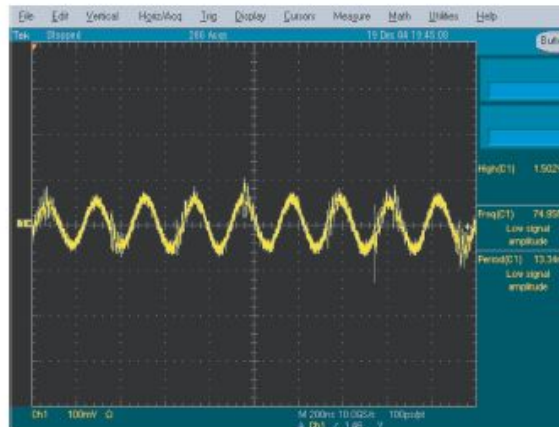

White Balance - Calibration

If picture color is wrong, do calibration first.

Equipment : CA210, Patten : chess pattern

Execute calibration in Factory Mode

Source AV : PAL composite, Component : 1280*720/60Hz

PC : 1024*768/60Hz

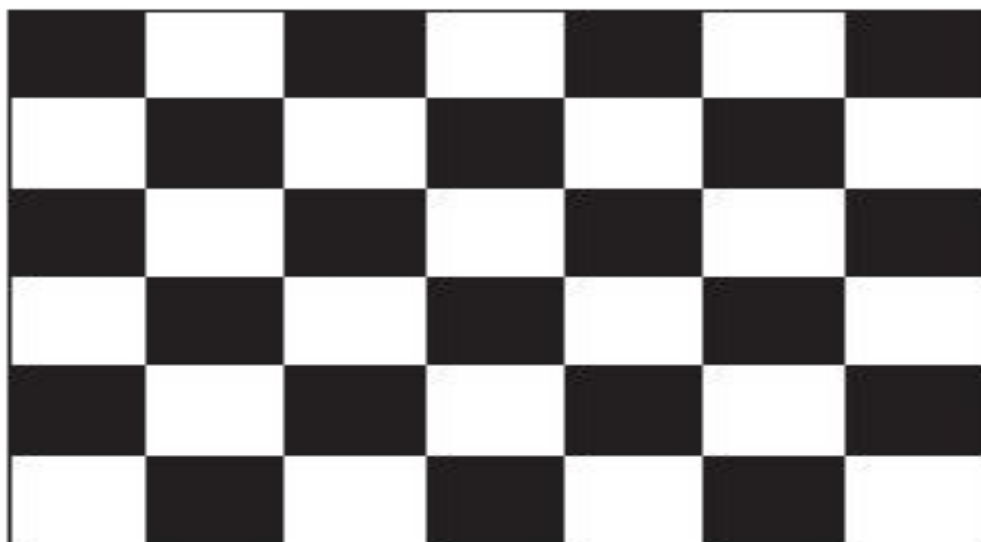

(chess patten)

White Balance - Adjustment

4-5. White Ratio (Balance) Adjustment

1. You can adjust the white ratio in factory mode (1:Calibration, 3:White-Balance).
2. Since the adjustment value and the data value vary depending on the input source, you have to adjust these in CVBS, Component 1 and HDMI 1 modes.
3. The optimal values for each mode are configured by default. (Refer to Table 1, 2)
It varies with Panel's size and Specification.

- Equipment : CS-210
- Pattern: MIK K-7256 #92 "Flat W/B Pattern" as standard
- Use other equipment only after comparing the result with that of the Master equipment.

- Set Aging time : 60min ↑

- Calibration and Manual setting for WB adjustment.



- | | |
|---|---|
| HDMI : Time #6 720P, Pattern #24 Chessboard Calibration | → Manual adjustment #92 pattern (720p) |
| COMP: Time #6 720P, Pattern #24 Chessboard Calibration | → Manual adjustment at #92 pattern (720p) |
| CVBS: Time #2 PAL, Pattern #24 Chessboard Calibration | → Manual adjustment at #92 pattern (NTSC) |
| PC: Time #21 1024*768, Pattern #24 Chessboard Calibration | → Manual adjustment at #92 pattern (NTSC) |

- If finishing in HDMI mode, adjustment coordinate is almost same in AV/COMP mode.
- White Balance Manual Adjustment

SW Information

Saturn4 DVB (Code Release)

Full HD B'd : T-CRLPEUFC-0152
Checksum : 0x3BDA)

HD B'd : T-CRLPEUHC-0152
(Checksum : 0xF9B1)

*Factory mode -> control -> sub option -> CheckSum

SW upgrade

Full HD B'd(Ver1000.0).zip(9117.23KB)
HD B'd(Ver1000.0).zip(8209.1KB)

*Please unzip this file to your HDD

*Copy the directory to root of USB memory and follow next page actions



*The folder has these files

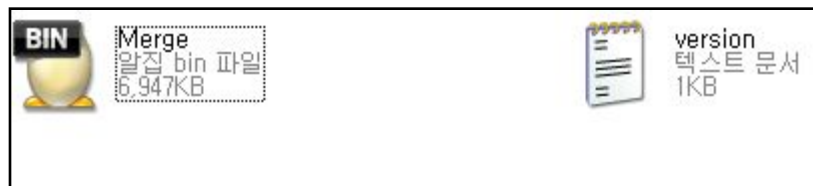

SW upgrade

Samsung may offer upgrades for TV's firmware in the future. Please contact the Samsung call center at 1-800-SAMSUNG (726-7864) to receive information about downloading upgrades and using a USB drive. Upgrades will be possible by connecting a USB drive to the USB port located on your TV.

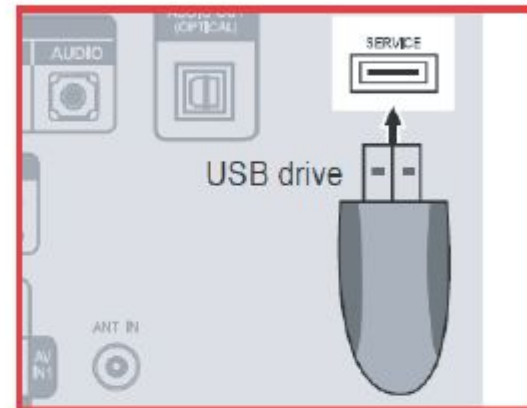

1. Insert a USB drive containing the firmware upgrade into the USB port on the rear of the TV.
2. Press the **MENU** button to display the menu.
Press the **▲** or **▼** button to select "Support", then press the **ENTER** button.
3. Press the **▲** or **▼** button to select "SW Upgrade", then press the **ENTER** button.
The message "Scanning for USB. It may take up to 30 seconds." is displayed.
4. The message "Upgrade version XXXX to version XXXX?" is displayed.
The system will be reset after upgrade.
Press the **◀** or **▶** to select the "OK", then press the **ENTER** button.

Please be careful to not disconnect the power or remove the USB drive while upgrades are being applied. The TV will turn off and turn on automatically after completing the firmware upgrade. Please check the firmware version after the upgrades are complete. When software is upgraded, video and audio settings you have made will return to their default (factory) settings. We recommend you write down your settings so that you can easily reset them after the upgrade.



HOW TO UPGRADE with JIG

1. TV Main S/W

Order	Description	ETC.
1	Open the Flash Downloader.	 <p>The screenshot shows the MStar ISP Utility V4.1.0 software window. The title bar reads 'MStar ISP Utility V4.1.0'. The toolbar contains several icons: Device, Load, Read, Auto, Blank, Program, Verify, Erase, Config, Connect, and Dis Con. The 'Connect' icon, which depicts a USB plug, is circled in red. The main area of the window displays the MStar Semiconductor logo. At the bottom, there are status indicators for 'Elapsed Time:', 'I2C', and 'USB 306KHz'.</p>
2	Connect Mstar JIG to the TV Set with D-SUB Cable.	 <p>The photograph shows the back of a television set with various ports. A green printed circuit board (the Mstar JIG) is connected to the TV's D-SUB port using a blue D-SUB cable. A white USB cable is also plugged into the JIG. The TV's control panel and other ports are visible in the background.</p> <p>One side is USB cable, the another side is D-Sub cable on the JIG.</p>

HOW TO UPGRADE with JIG

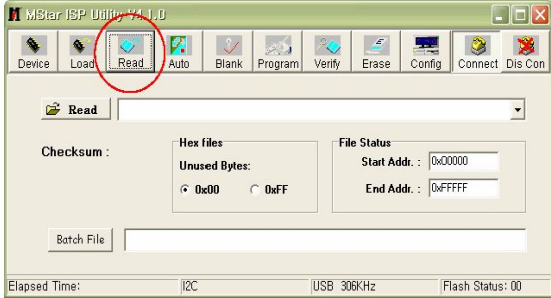
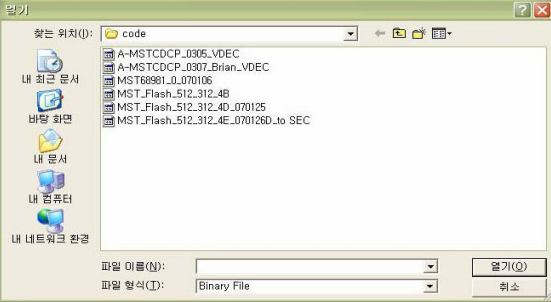
<p>3</p>	<p>JIG connection is OK</p>		
<p>4</p>	<p>Select the code</p>		
<p>5</p>	<p>Choose the S/W</p>		

HOW TO UPGRADE with JIG

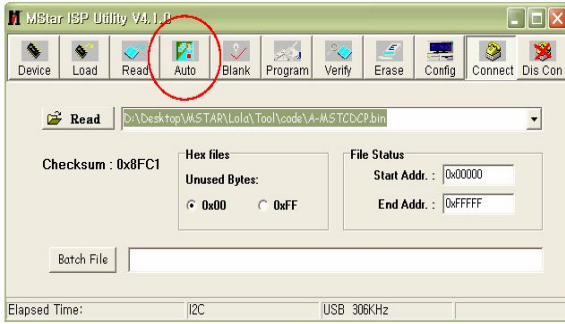
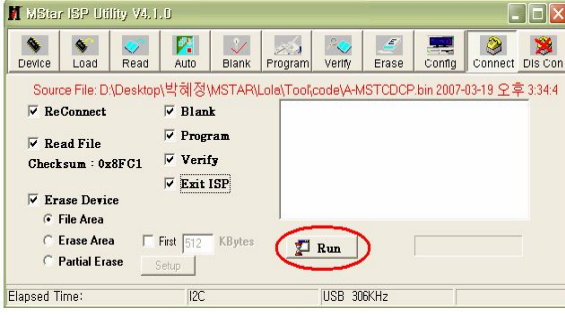
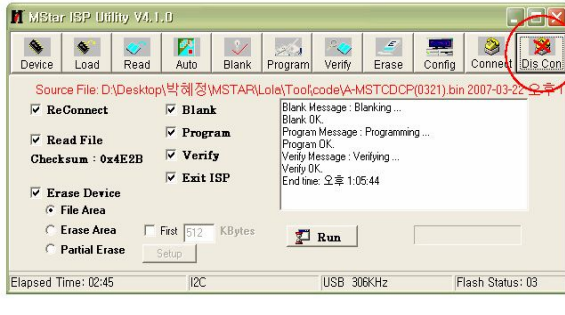
<p>3</p>	<p>Select AUTO button</p>		
<p>4</p>	<p>Select RUN button</p>		
<p>5</p>	<p>Check the Verify OK, Select DIS Con Button And disconnect the JIG</p>		

Appendix

1. Feature & Specification
2. PC timing of FHD & HD
3. Comparison of User key pad
4. Signal Flows Information
5. IP Schematic Diagram

1. Feature & Specification

Model	LE32B53***	
Feature		
<ul style="list-style-type: none"> ▶ DTV/ATV, 3-HDMI, 1-Component, 1-A/V, D-SUB, 1-SCART ▶ Brightness : 500cd/m² ▶ High Contrast Ratio : 5000:1 ▶ Response Time : 6.5ms 		
Specifications		
Item	Description	
LCD Panel	DIGITAL-TV, RF, 3-HDMI, 1-COMPONENT, 1-A/V, D-SUB, 1-SCART	
Scanning Frequency	Horizontal : 30 kHz ~ 80 kHz (Automatic) Vertical : 47 Hz ~ 75 Hz (Automatic)	
Display Colors	16.7 million colors	
Maximum resolution	Horizontal : 1920 Pixels Vertical : 1080 pixels	
Input Signal	Analog 0.7 Vp-p ± 5% positive at 75Ω , internally terminated	
Input Sync Signal	H/V Separate, TTL, P. or N.	
Maximum Pixel Clock rate	310MHz	
Active Display Horizontal/Vertical	27.47 x 15.44 inches (697.68(H) x 392.26(V)mm)	
AC power voltage & Frequency	AC 110V ~ 220V, 60 Hz	
Power Consumption	<130W (< 1W, stand by)	
Dimensions Set (W x D x H)	801 x 77 x 518 mm_with stand 801 x 220 x 562 mm_without stand	
Weight	12 kg	
TV System	Tuning	Frequency Synthesize (Refer to detailed Frequency Table)
	System	DVB-T/C, PAL, SECAM, NT4.43
	Sound	BG, DK, L/L', NICAM, MPEG1, DD, DD+, HE-AAC
Environmental Considerations	Operating Temperature : 50°F ~ 104°F (10°C ~ 40°C) Operating Humidity : 10% ~ 80%, non-condensing Storage temperature : -13°F ~ 113°F (-25°C ~ 45°C) Storage Humidity : 5% ~ 95%, non-condensing	
Audio Spec.	<ul style="list-style-type: none"> - MAX Internal speaker Out : Right => 10W, Left => 10W - BASS Control Range : -8 dB ~ + 8dB - TREBLE Control Range : -8 dB ~ +8 dB - Headphone Out : 10 mW MAX - Output Frequency : RF : 80 Hz ~ 15 kHz A/V : 80 Hz ~ 20 kHz 	
Note: TruSurround HD, Film Mode, Energy Saving, Anynet+		

1. Feature & Specification

Model		LE37B53***	
Feature			
<ul style="list-style-type: none"> ▶ DTV/ATV, 3-HDMI, 1-Component, 1-A/V, D-SUB, 1-SCART ▶ Brightness : 500cd/m² ▶ High Contrast Ratio : 5000:1 ▶ Response Time : 6.5ms 			
Specifications			
Item		Description	
LCD Panel		DIGITAL-TV, RF, 3-HDMI, 1-COMPONENT, 1-A/V, D-SUB, 1-SCART	
Scanning Frequency		Horizontal : 30 kHz ~ 80 kHz (Automatic) Vertical : 47 Hz ~ 75 Hz (Automatic)	
Display Colors		16.7 million colors	
Maximum resolution		Horizontal : 1920 Pixels Vertical : 1080 pixels	
Input Signal		Analog 0.7 Vp-p ± 5% positive at 75Ω , internally terminated	
Input Sync Signal		H/V Separate, TTL, P. or N.	
Maximum Pixel Clock rate		310MHz	
Active Display Horizontal/Vertical		32.27 x 18.14 inches (819.6(H) x 460.8(V)mm)	
AC power voltage & Frequency		AC 110V ~ 220V, 60 Hz	
Power Consumption		<140W (< 1W, stand by)	
Dimensions Set (W x D x H)		918 x 77 x 597 mm_with stand 918 x 300 x 650 mm_without stand	
Weight		15 kg	
TV System		Tuning	Frequency Synthesize (Refer to detailed Frequency Table)
		System	DVB-T/C, PAL, SECAM, NT4.43
		Sound	BG, DK, L/L', NICAM, MPEG1, DD, DD+, HE-AAC
Environmental Considerations		Operating Temperature : 50°F ~ 104°F (10°C ~ 40°C) Operating Humidity : 10% ~ 80%, non-condensing Storage temperature : -13°F ~ 113°F (-25°C ~ 45°C) Storage Humidity : 5% ~ 95%, non-condensing	
Audio Spec.		- MAX Internal speaker Out : Right => 10W, Left => 10W - BASS Control Range : -8 dB ~ + 8dB - TREBLE Control Range : -8 dB ~ +8 dB - Headphone Out : 10 mW MAX - Output Frequency : RF : 80 Hz ~ 15 kHz A/V : 80 Hz ~ 20 kHz	
Note: TruSurround HD, Film Mode, Energy Saving, Anynet+			

1. Feature & Specification

Model		LE40B53***	
Feature			
<ul style="list-style-type: none"> ▶ DTV/ATV, 3-HDMI, 1-Component, 1-A/V, D-SUB, 1-SCART ▶ Brightness : 500cd/m² ▶ High Contrast Ratio : 5000:1 ▶ Response Time : 6.5ms 			
Specifications			
Item		Description	
LCD Panel		DIGITAL-TV, RF, 3-HDMI, 1-COMPONENT, 1-A/V, D-SUB, 1-SCART	
Scanning Frequency		Horizontal : 30 kHz ~ 80 kHz (Automatic) Vertical : 47 Hz ~ 75 Hz (Automatic)	
Display Colors		16.7 million colors	
Maximum resolution		Horizontal : 1920 Pixels Vertical : 1080 pixels	
Input Signal		Analog 0.7 Vp-p ± 5% positive at 75Ω , internally terminated	
Input Sync Signal		H/V Separate, TTL, P. or N.	
Maximum Pixel Clock rate		310MHz	
Active Display Horizontal/Vertical		34.85 x 19.59 inches (885.2(H) x 497.7(V)mm)	
AC power voltage & Frequency		AC 110V ~ 220V, 60 Hz	
Power Consumption		<180W (< 1W, stand by)	
Dimensions Set (W x D x H)		998 x 78 x 621 mm_with stand 998 x 260 x 686 mm_without stand	
Weight		18 kg	
TV System		Tuning	Frequency Synthesize (Refer to detailed Frequency Table)
		System	DVB-T/C, PAL, SECAM, NT4.43
		Sound	BG, DK, L/L', NICAM, MPEG1, DD, DD+, HE-AAC
Environmental Considerations		Operating Temperature : 50°F ~ 104°F (10°C ~ 40°C) Operating Humidity : 10% ~ 80%, non-condensing Storage temperature : -13°F ~ 113°F (-25°C ~ 45°C) Storage Humidity : 5% ~ 95%, non-condensing	
Audio Spec.		- MAX Internal speaker Out : Right => 10W, Left => 10W - BASS Control Range : -8 dB ~ + 8dB - TREBLE Control Range : -8 dB ~ +8 dB - Headphone Out : 10 mW MAX - Output Frequency : RF : 80 Hz ~ 15 kHz A/V : 80 Hz ~ 20 kHz	
Note: TruSurround HD, Film Mode, Energy Saving, Anynet+			

1. Feature & Specification

Model		LE46B53***	
Feature			
<ul style="list-style-type: none"> ▶ DTV/ATV, 3-HDMI, 1-Component, 1-A/V, D-SUB, 1-SCART ▶ Brightness : 500cd/m² ▶ High Contrast Ratio : 5000:1 ▶ Response Time : 6.5ms 			
Specifications			
Item		Description	
LCD Panel		DIGITAL-TV, RF, 3-HDMI, 1-COMPONENT, 1-A/V, D-SUB, 1-SCART	
Scanning Frequency		Horizontal : 30 kHz ~ 80 kHz (Automatic) Vertical : 47 Hz ~ 75 Hz (Automatic)	
Display Colors		16.7 million colors	
Maximum resolution		Horizontal : 1920 Pixels Vertical : 1080 pixels	
Input Signal		Analog 0.7 Vp-p ± 5% positive at 75Ω , internally terminated	
Input Sync Signal		H/V Separate, TTL, P. or N.	
Maximum Pixel Clock rate		310MHz	
Active Display Horizontal/Vertical		40.08 x 22.55 inches (1018.08 (H) x 572.67 (V) mm)	
AC power voltage & Frequency		AC 110V ~ 220V, 60 Hz	
Power Consumption		<240W (< 1W, stand by)	
Dimensions Set (W x D x H)		1127 x 78 x 712 mm_with stand 1127 x 260 x 766 mm_without stand	
Weight		18 kg	
TV System		Tunning	Frequency Synthesize (Refer to detailed Frequency Table)
		System	DVB-T/C, PAL, SECAM, NT4.43
		Sound	BG, DK, L/L', NICAM, MPEG1, DD, DD+, HE-AAC
Environmental Considerations		Operating Temperature : 50°F ~ 104°F (10°C ~ 40°C) Operating Humidity : 10% ~ 80%, non-condensing Storage temperature : -13°F ~ 113°F (-25°C ~ 45°C) Storage Humidity : 5% ~ 95%, non-condensing	
Audio Spec.		<ul style="list-style-type: none"> - MAX Internal speaker Out : Right => 10W, Left => 10W - BASS Control Range : -8 dB ~ + 8dB - TREBLE Control Range : -8 dB ~ +8 dB - Headphone Out : 10 mW MAX - Output Frequency : RF : 80 Hz ~ 15 kHz A/V : 80 Hz ~ 20 kHz 	
Note: TruSurround HD, Film Mode, Energy Saving, Anynet+			

1. Feature & Specification

Model	LE19B45***	
Feature		
<ul style="list-style-type: none"> ▶ DIGITAL-TV, RF, 1-HDMI, 1-COMPONENT, 1-A/V, D-SUB, 1-SCART ▶ Brightness : 250cd/m² ▶ High Contrast Ratio : 1000:1 ▶ Response Time : 5ms 		
Specifications		
Item	Description	
LCD Panel	TFT-LCD Panel, RGB Vertical Stripe, Normally white, TN	
Scanning Frequency	Horizontal : 40 kHz ~ 80 kHz (Automatic) Vertical : 47 Hz ~ 63 Hz (Automatic)	
Display Colors	16.7M color	
Maximum resolution	Horizontal : 1366 Pixels Vertical : 768 pixels	
Input Signal	Analog 0.7 Vp-p ± 5% positive at 75Ω , internally terminated	
Input Sync Signal	H/V Separate, TTL, P. or N.	
Maximum Pixel Clock rate	89MHz	
Active Display Horizontal/Vertical	16.13 x 9.07 inches (409.8(H) x 230.4 (V) mm)	
AC power voltage & Frequency	AC 110V ~ 240 @ 50/60 Hz	
Power Consumption	Under 50W (Under 1W , Stand by)	
Dimensions Set (W x D x H)	18.8 x 7.1 x 14.7 inches (477.1 x 180.25 x 374 mm)_with stand 18.8 x 2.6 x 12.9 inches (477.1 x 65.5 x 326.9 mm)_without stand	
Weight	10.58 lbs (4.8Kg)_with stand 9.26lbs(9.8Kg)_without stand	
TV System	Tuning	Frequency Synthesize (Refer to detailed Frequency Table)
	System	PAL/SECAM, DVB-T/C
	Sound	MONO, STEREO, NICAM, MPEG, DD, DD+, HE-AAC
Environmental Considerations	Operating Temperature : 50°F ~ 104°F (10°C ~ 40°C) Operating Humidity : 10% ~ 80%, non-condensing Storage temperature : -13°F ~ 113°F (-25°C ~ 45°C) Storage Humidity : 5% ~ 95%, non-condensing	
Audio Spec.	<ul style="list-style-type: none"> - MAX Internal Audio Output Power : Each 3W(Left/Right) - BASS Control Range : -8 dB ~ + 8dB - TREBLE Control Range : -8 dB ~ +8 dB - Headphone Out : 10 mW MAX - Output Frequency : RF : 80 Hz ~ 15 kHz A/V : 80 Hz ~ 20 kHz 	
Note: TruSurround HD, Game Mode, Energy Saving		

1. Feature & Specification

Model	LE22B45***	
Feature		
<ul style="list-style-type: none"> ▶ DIGITAL-TV, RF, 1-HDMI, 1-COMPONENT, 1-A/V, D-SUB, 1-SCART ▶ Brightness : 400cd/m² ▶ High Contrast Ratio : 800:1 ▶ Response Time : 5ms 		
Specifications		
Item	Description	
LCD Panel	TFT-LCD Panel, RGB Vertical Stripe, Normally white, TN	
Scanning Frequency	Horizontal : 40 kHz ~ 80 kHz (Automatic) Vertical : 47 Hz ~ 63 Hz (Automatic)	
Display Colors	16.7M color	
Maximum resolution	Horizontal : 1366 Pixels Vertical : 768 pixels	
Input Signal	Analog 0.7 Vp-p ± 5% positive at 75Ω , internally terminated	
Input Sync Signal	H/V Separate, TTL, P. or N.	
Maximum Pixel Clock rate	82MHz	
Active Display Horizontal/Vertical	18.80 x 10.57 inches (477.42(H) x 268.42(V) mm)	
AC power voltage & Frequency	AC 110V ~ 240 @ 50/60 Hz	
Power Consumption	Under 60W (Under 1W , Stand by)	
Dimensions Set (W x D x H)	22.0 x 8.5 x 17.2 inches (557.8 x 216 x 437.4 mm)_with stand 22.0 x 3.0 x 15.1 inches (557.8 x 75 x 384.1 mm)_without stand	
Weight	12.13 lbs (6.5Kg)_with stand 11.24 lbs (5.1Kg)_without stand	
TV System	Tuning	Frequency Synthesize (Refer to detailed Frequency Table)
	System	PAL/SECAM, DVB-T/C
	Sound	MONO, STEREO, NICAM, MPEG, DD, DD+, HE-AAC
Environmental Considerations	Operating Temperature : 50°F ~ 104°F (10°C ~ 40°C) Operating Humidity : 10% ~ 80%, non-condensing Storage temperature : -13°F ~ 113°F (-25°C ~ 45°C) Storage Humidity : 5% ~ 95%, non-condensing	
Audio Spec.	<ul style="list-style-type: none"> - MAX Internal Audio Output Power : Each 3W(Left/Right) - BASS Control Range : -8 dB ~ +8dB - TREBLE Control Range : -8 dB ~ +8 dB - Headphone Out : 10 mW MAX - Output Frequency : RF : 80 Hz ~ 15 kHz A/V : 80 Hz ~ 20 kHz 	
Note: TruSurround HD, Game Mode, Energy Saving		

1. Feature & Specification

Model	LE26B45***	
Feature		
<ul style="list-style-type: none"> ▶ DIGITAL-TV, RF, 3-HDMI, 1-COMPONENT, 1-A/V, D-SUB, 1-SCART ▶ Brightness : 450cd/m² ▶ High Contrast Ratio : 3000:1 ▶ Response Time : 5ms 		
Specifications		
Item	Description	
LCD Panel	TFT-LCD Panel, RGB Vertical stripe, Normaly balck	
Scanning Frequency	Horizontal : 40 kHz ~ 80 kHz (Automatic) Vertical : 47 Hz ~ 63 Hz (Automatic)	
Display Colors	16.7M color	
Maximum resolution	Horizontal : 1366 Pixels Vertical : 768 pixels	
Input Signal	Analog 0.7 Vp-p ± 5% positive at 75Ω , internally terminated	
Input Sync Signal	H/V Separate, TTL, P. or N.	
Maximum Pixel Clock rate	86MHz	
Active Display Horizontal/Vertical	22.7 x 12.7 inches (525.8(H) x 323.7(V) mm)	
AC power voltage & Frequency	AC 110V ~ 240 @ 50/60 Hz	
Power Consumption	Under 80W (Under 1W , Stand by)	
Dimensions Set (W x D x H)	26.4 x 8.5 x 19.5 inches (669.7 x 216 x 495.1 mm)_with stand 26.4 x 3.0 x 17.9 inches (669.7 x 75.3 x 455.0 mm)_without stand	
Weight	18.52 lbs (8.4Kg)_with stand 15.43 lbs (7Kg)_without stand	
TV System	Tunning	Frequency Synthesize (Refer to detailed Frequency Table)
	System	PAL/SECAM, DVB-T/C
	Sound	MONO, STEREO, NICAM, MPEG, DD, DD+, HE-AAC
Environmental Considerations	Operating Temperature : 50°F ~ 104°F (10°C ~ 40°C) Operating Humidity : 10% ~ 80%, non-condensing Storage temperature : -13°F ~ 113°F (-25°C ~ 45°C) Storage Humidity : 5% ~ 95%, non-condensing	
Audio Spec.	<ul style="list-style-type: none"> - MAX Internal Audio Output Power : Each 3W(Left/Right) - BASS Control Range : -8 dB ~ +8dB - TREBLE Control Range : -8 dB ~ +8 dB - Headphone Out : 10 mW MAX - Output Frequency : RF : 80 Hz ~ 15 kHz A/V : 80 Hz ~ 20 kHz 	
Note: TruSurround HD, Game Mode, Energy Saving		

1. Feature & Specification

Model	LE32B45***	
Feature		
<ul style="list-style-type: none"> ▶ DIGITAL-TV, RF, 3-HDMI, 1-COMPONENT, 1-A/V, D-SUB, 1-SCART ▶ Brightness : 450cd/m² ▶ High Contrast Ratio : 5000:1 ▶ Response Time : 8ms 		
Specifications		
Item	Description	
LCD Panel	TFT-LCD Panel, RGB Vertical stripe, Normaly balck	
Scanning Frequency	Horizontal : 44 kHz ~ 53 kHz (Automatic) Vertical : 50 Hz ~ 60 Hz (Automatic)	
Display Colors	16.7M color	
Maximum resolution	Horizontal : 1366 Pixels Vertical : 768 pixels	
Input Signal	Analog 0.7 Vp-p ± 5% positive at 75Ω , internally terminated	
Input Sync Signal	H/V Separate, TTL, P. or N.	
Maximum Pixel Clock rate	85MHz	
Active Display Horizontal/Vertical	27.47 x 11.50 inches (697.68(H) x 392.26(V) mm)	
AC power voltage & Frequency	AC 110V ~ 240 @ 50/60 Hz	
Power Consumption	Under 130W (Under 1W , Stand by)	
Dimensions Set (W x D x H)	31.4 x 9.9 x 29.8 inches (797.7 x 252 x 756.5 mm)_with stand 31.4 x 3.3 x 20.9 inches (797.7 x 84.8 x 530.5 mm)_without stand	
Weight	20.79 lbs (11.7Kg)_with stand 20.72 lbs (9.4Kg)_without stand	
TV System	Tuning	Frequency Synthesize (Refer to detailed Frequency Table)
	System	PAL/SECAM, DVB-T/C
	Sound	MONO, STEREO, NICAM, MPEG, DD, DD+, HE-AAC
Environmental Considerations	Operating Temperature : 50°F ~ 104°F (10°C ~ 40°C) Operating Humidity : 10% ~ 80%, non-condensing Storage temperature : -13°F ~ 113°F (-25°C ~ 45°C) Storage Humidity : 5% ~ 95%, non-condensing	
Audio Spec.	<ul style="list-style-type: none"> - MAX Internal Audio Output Power : Each 3W(Left/Right) - BASS Control Range : -8 dB ~ + 8dB - TREBLE Control Range : -8 dB ~ +8 dB - Headphone Out : 10 mW MAX - Output Frequency : RF : 80 Hz ~ 15 kHz A/V : 80 Hz ~ 20 kHz 	
Note: TruSurround HD, Game Mode, Energy Saving		

2. PC Timing

No	Display Mode			New FHD TV		Horizontal Frequency (kHz)	Vertical Frequency (Hz)	Pixel Clock (MHz)	Sync Polarity (H/V)
	Originator	Resolution		PC	HDMI				
1	IBM	640 x 350	70Hz	O	O	31.469	70.086	25.175	+/-
2	VESA DMT	640 x 480	60Hz	O	O	31.469	59.940	25.175	-/-
3	MAC	640 x 480	67Hz	O	O	35.000	66.667	30.240	-/-
4	VESA DMT	640 x 480	72Hz	O	O	37.861	72.809	31.500	-/-
5			75Hz	O	O	37.500	75.000	31.500	-/-
6	IBM	720 x 400	70Hz	O	O	31.469	70.087	28.322	-/+
7	VESA CVT	720 x 576	60Hz	O	O	35.910	59.950	32.750	-/+
8	VESA DMT	800 x 600	60Hz	O	O	37.879	60.317	40.000	+/+
9	VESA DMT	800 x 600	72Hz	O	O	48.077	72.188	50.000	+/+
10			75Hz	O	O	46.875	75.000	49.500	+/+
11	MAC	832 x 624	75Hz	O	O	49.726	74.551	57.284	-/-
12	VESA DMT	1024 x 768	60Hz	O	O	48.363	60.004	65.000	-/-
13			70Hz	O	O	56.476	70.069	75.000	-/-
14	VESA DMT	1024 x 768	75Hz	O	O	60.023	75.029	78.750	+/+
15	VESA CVT	1152 x 864	60Hz	O	O	53.783	59.959	81.750	-/+
16	VESA DMT	1152 x 864	75Hz	O	O	67.500	75.000	108.000	+/+
17	MAC	1152 x 870	75Hz	O	O	68.681	75.062	100.000	-/-
18	VESA CVT	1280 x 720	60Hz	O	O	44.772	59.855	74.500	-/+
19	VESA GTF		70Hz	O	O	52.500	70.000		-/+
20	VESA CVT	1280 x 720	75Hz	O	O	56.456	74.777	95.750	-/+
21	VESA DMT	1280 x 800	60Hz	O	O	49.702	59.810	83.500	-/+
22			75Hz	O	O	62.795	74.934	106.500	-/+
23		1280 x 960	60Hz	O	O	60.000	60.000	108.000	+/+
24	VESA CVT	1280 x 960	75Hz	O	O	75.231	74.857	130.000	-/+
25	VESA DMT	1280 x 1024	60Hz	O	O	63.981	60.020	108.000	+/+
26	VESA GTF	1280 x 1024	70Hz	O	O	74.620	70.000	128.943	-/-
27	VESA DMT	1280 x 1024	75Hz	O	O	79.976	75.025	135.000	+/+
28			1360 x 768	60Hz	O	O	47.712	60.015	85.500
29		1440 x 900	60Hz	O	O	55.935	59.887	106.500	-/+
30			75Hz	O	O	70.635	74.984	136.750	-/+
31		1680 x 1050	60Hz	O	O	65.290	59.954	146.250	-/+
32	VESA DMT	1600 x 1200	60Hz	O	O	75.000	60.000	162.000	+/+
33	VESA DMT / DTV CEA	1920 x 1080p	60Hz	O	O	67.500	60.000	148.500	+/+

2. PC Timing

No	Display Mode			New HD TV		Horizontal Frequency (kHz)	Vertical Frequency (Hz)	Pixel Clock (MHz)	Sync Polarity (H/V)
	Originator	Resolution		PC	HDMI				
1	IBM	640 x 350	70Hz	O	O	31.469	70.086	25.175	+/-
2	VESA DMT	640 x 480	60Hz	O	O	31.469	59.940	25.175	-/-
3	MAC	640 x 480	67Hz	O	O	35.000	66.667	30.240	-/-
4	VESA DMT	640 x 480	72Hz	O	O	37.861	72.809	31.500	-/-
5			75Hz	O	O	37.500	75.000	31.500	-/-
6	IBM	720 x 400	70Hz	O	O	31.469	70.087	28.322	-/+
7	VESA CVT	720 x 576	60Hz	O	O	35.910	59.950	32.750	-/+
8	VESA DMT	800 x 600	60Hz	O	O	37.879	60.317	40.000	+/+
9	VESA DMT	800 x 600	72Hz	O	O	48.077	72.188	50.000	+/+
10			75Hz	O	O	46.875	75.000	49.500	+/+
11	MAC	832 x 624	75Hz	O	O	49.726	74.551	57.284	-/-
12	VESA DMT	1024 x 768	60Hz	O	O	48.363	60.004	65.000	-/-
13			70Hz	O	O	56.476	70.069	75.000	-/-
14	VESA DMT	1024 x 768	75Hz	O	O	60.023	75.029	78.750	+/+
18	VESA CVT	1280 x 720	60Hz	O	O	44.772	59.855	74.500	-/+
19	VESA GTF		70Hz	O	O	52.500	70.000	89.040	-/+
17	VESA CVT	1280 x 720	75Hz	O	O	56.456	74.777	95.750	-/+
18	VESA DMT	1360 x 768	60Hz	O	O	47.712	60.015	85.500	+/+

3. Comparison of User key pad

Touch Type [B350,B460,B650 models]

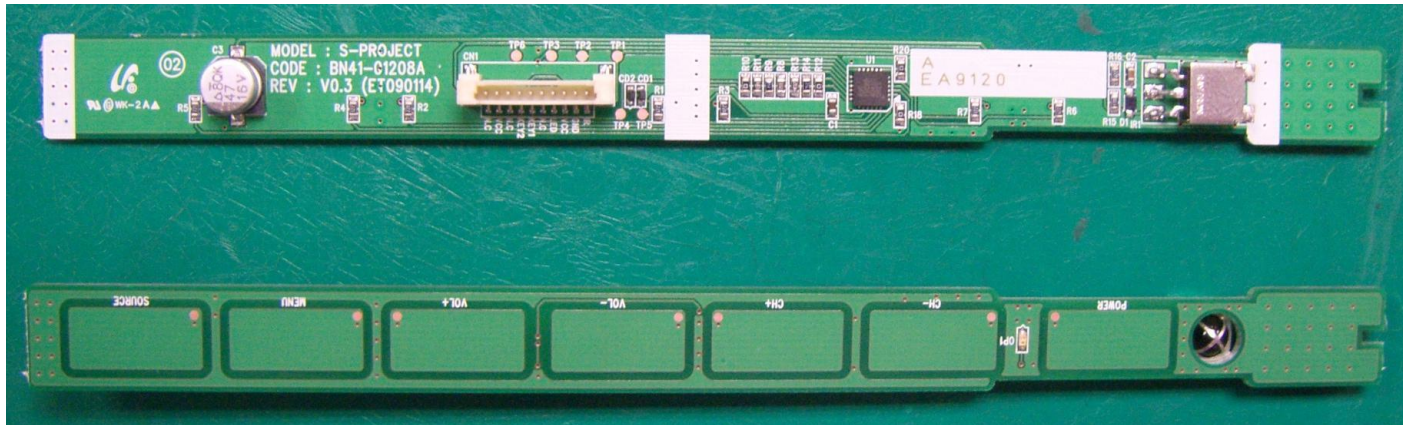

Tact Switch Type [B450,B530 models]

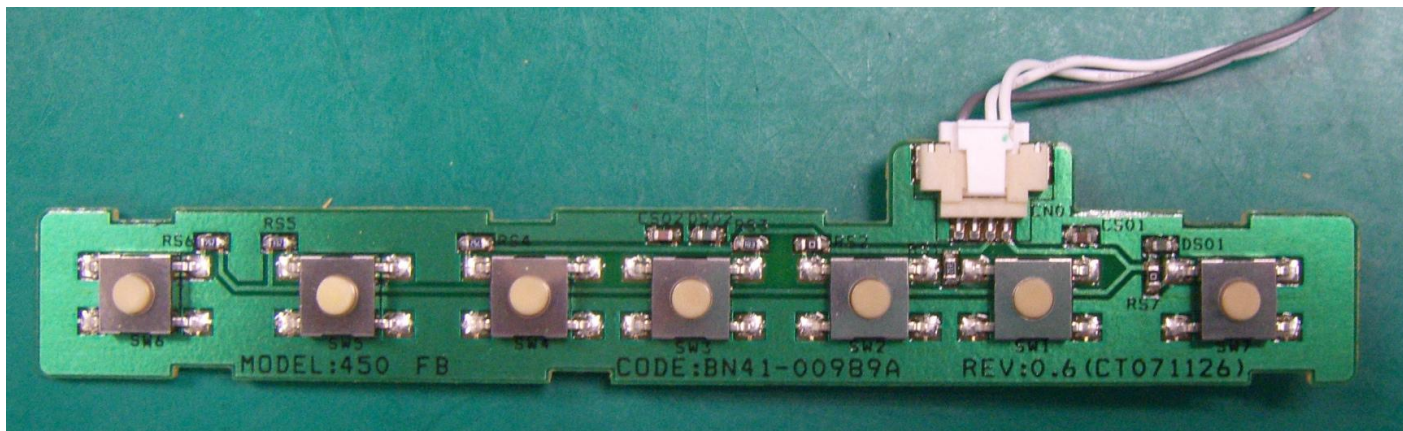

Contents

1. PC Input
2. Tuner Input
3. Component Input
4. HDMI Input
5. SCART Input
6. AV Input
7. SEMS12 Input & Output
 - .AUDIO
 - .CVBS & RGB Analog
 - .HDMI
 - .DDR
 - .CI
 - .LVDS Output
8. Sound AMP

4. Signal Flows Information

PC INPUT

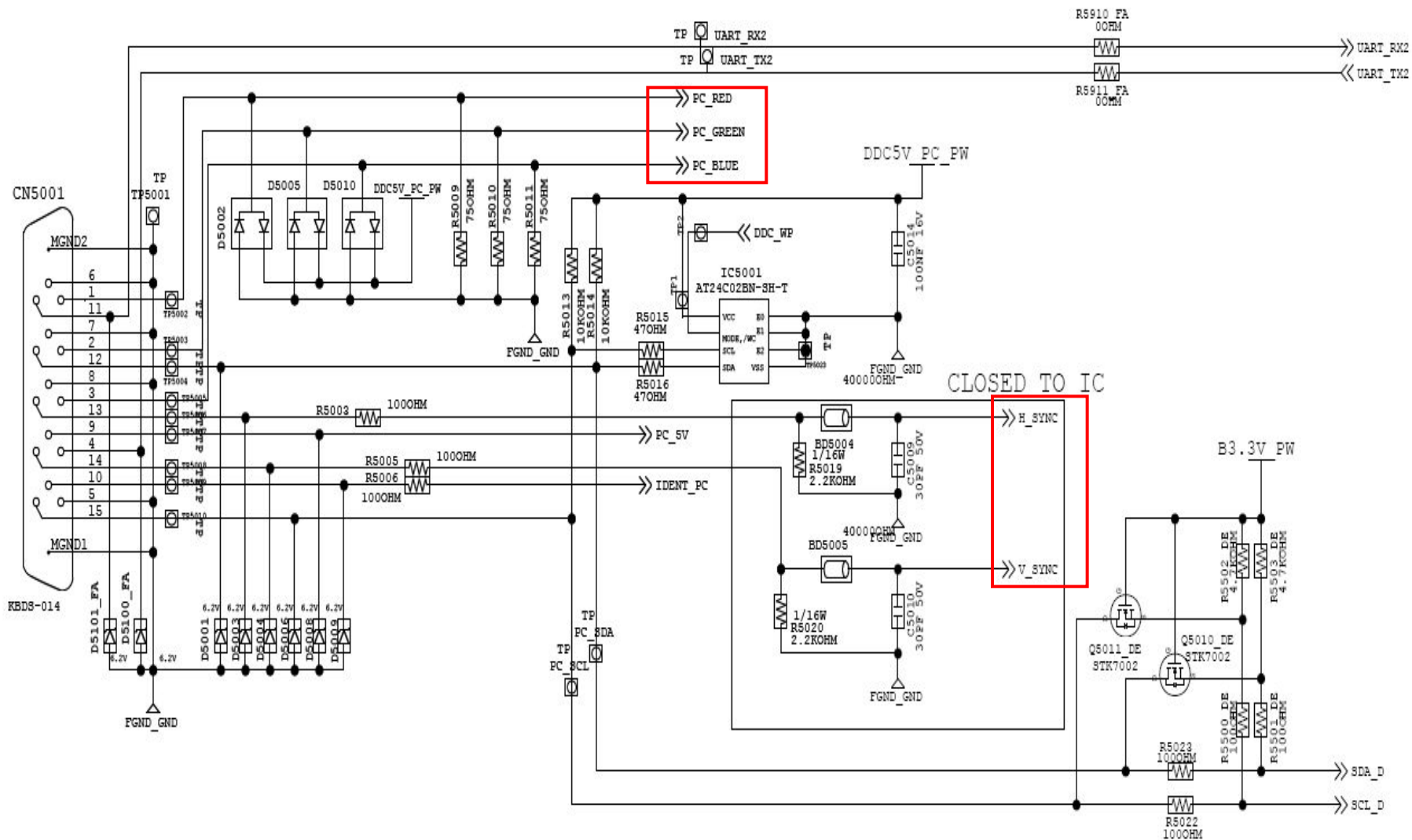

4. Signal Flows Information

TUNER

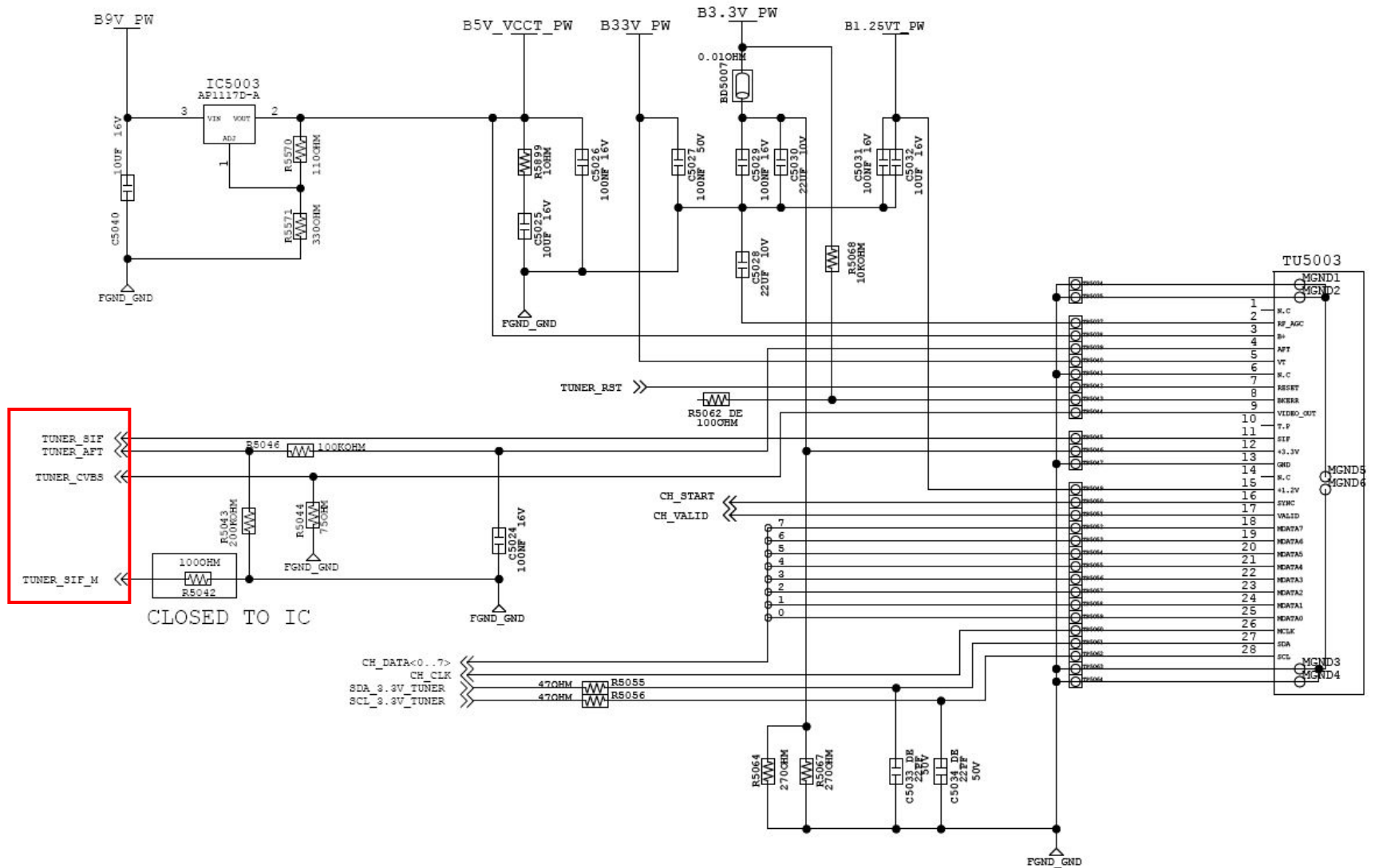

4. Signal Flows Information

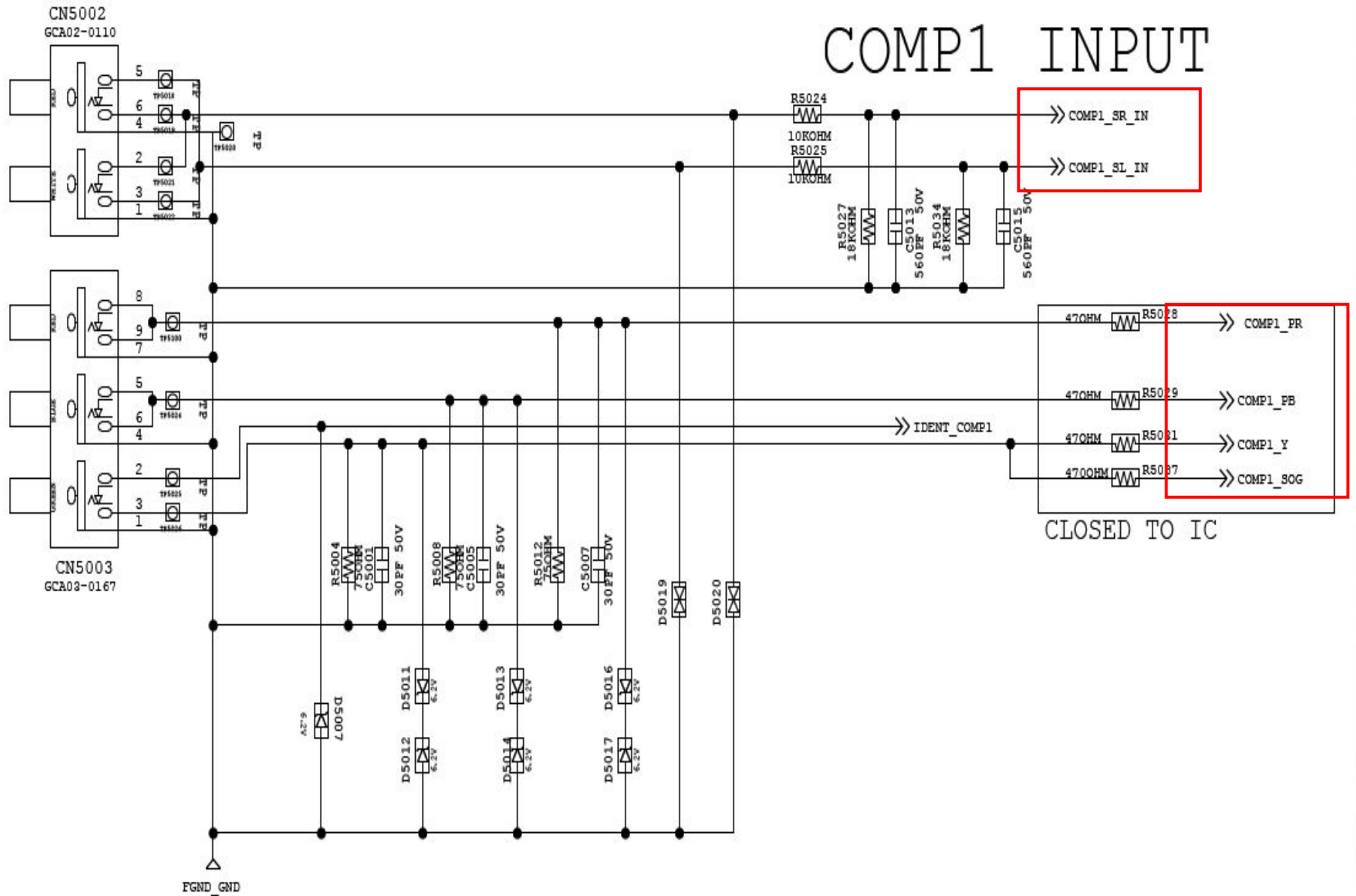

4. Signal Flows Information

HDMI INPUT1

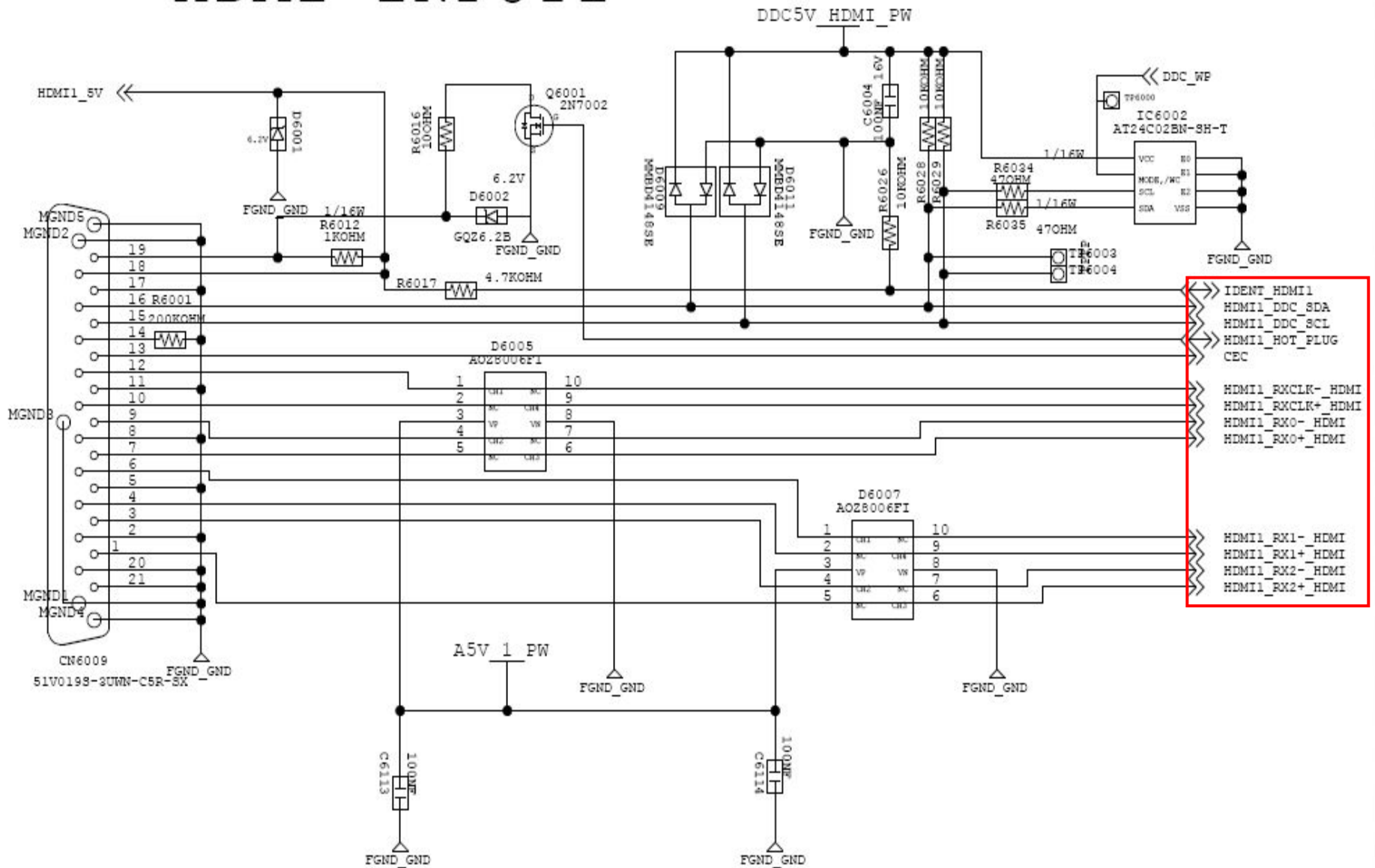

4. Signal Flows Information

SCART

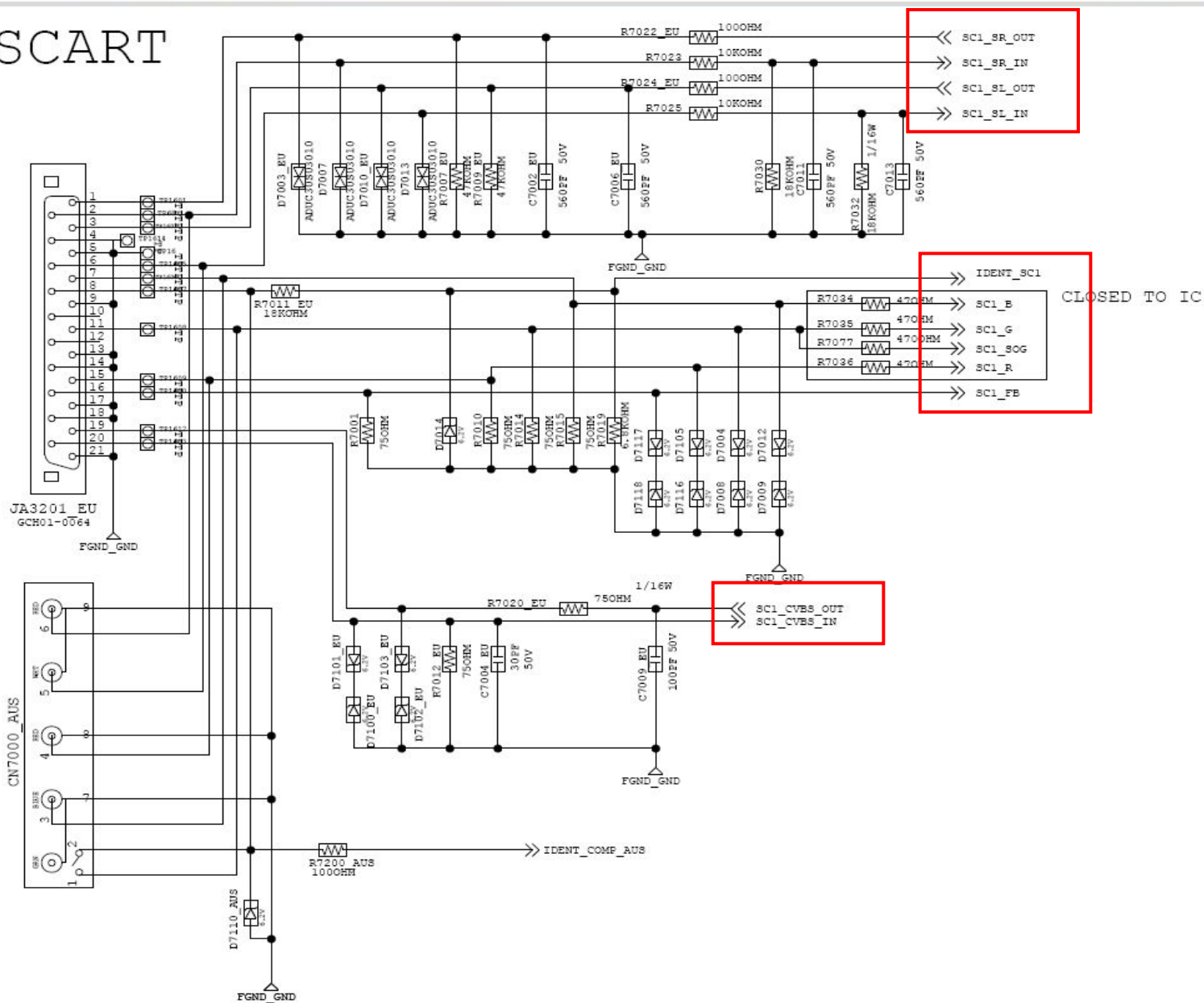

4. Signal Flows Information

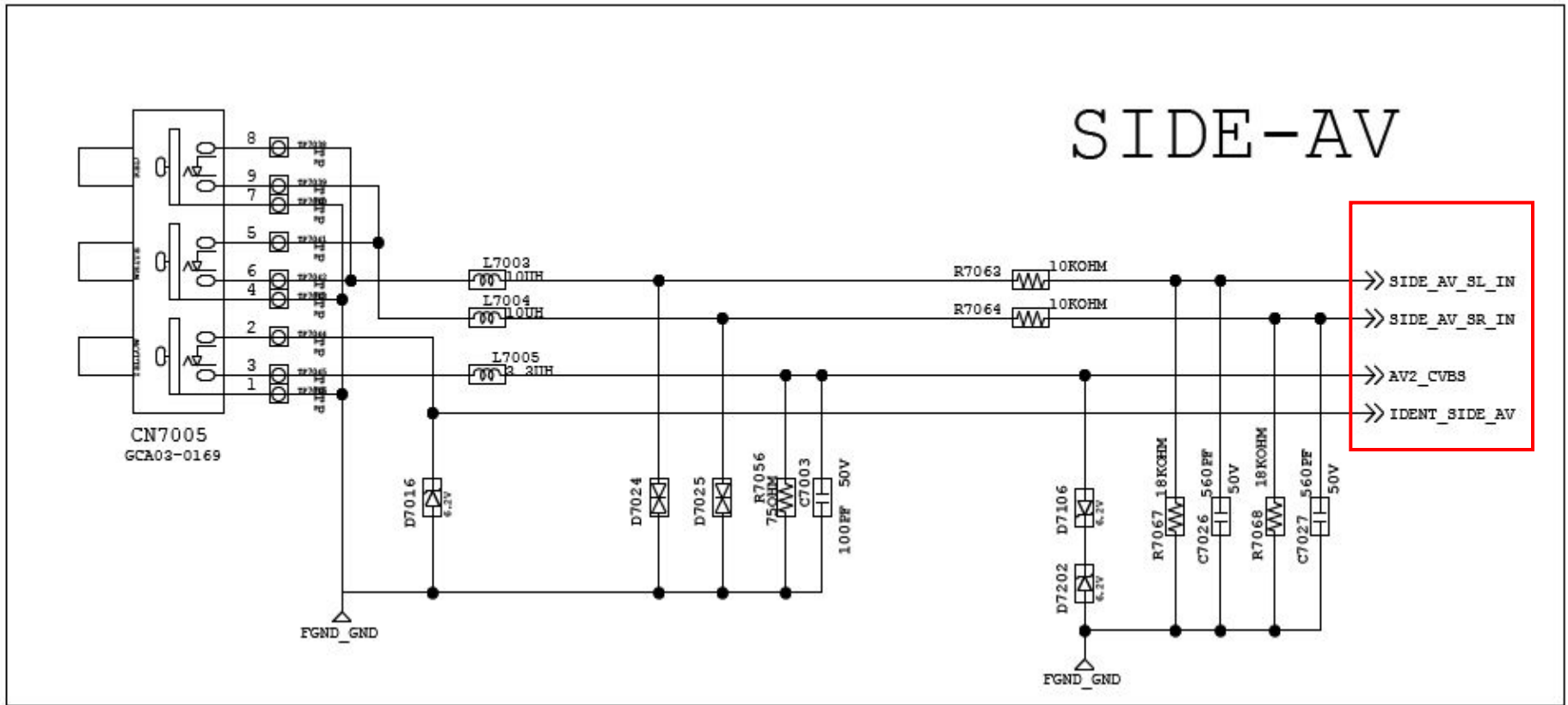

4. Signal Flows Information

CVBS RGB

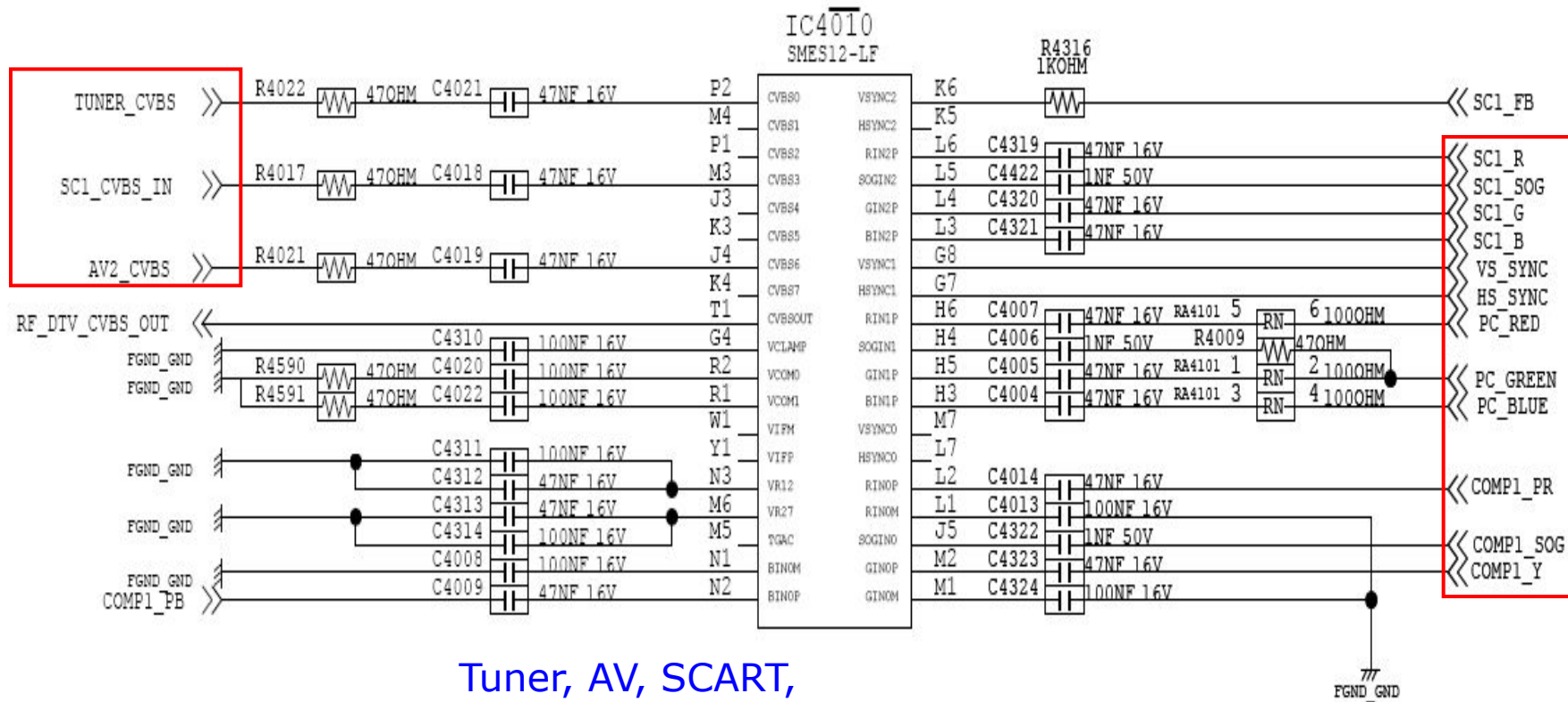

Tuner, AV, SCART,
COMPONENT ALL
VIDEO INPUT
SIGNALS go into
SEMS12 directly,
there is no switch.

4. Signal Flows Information

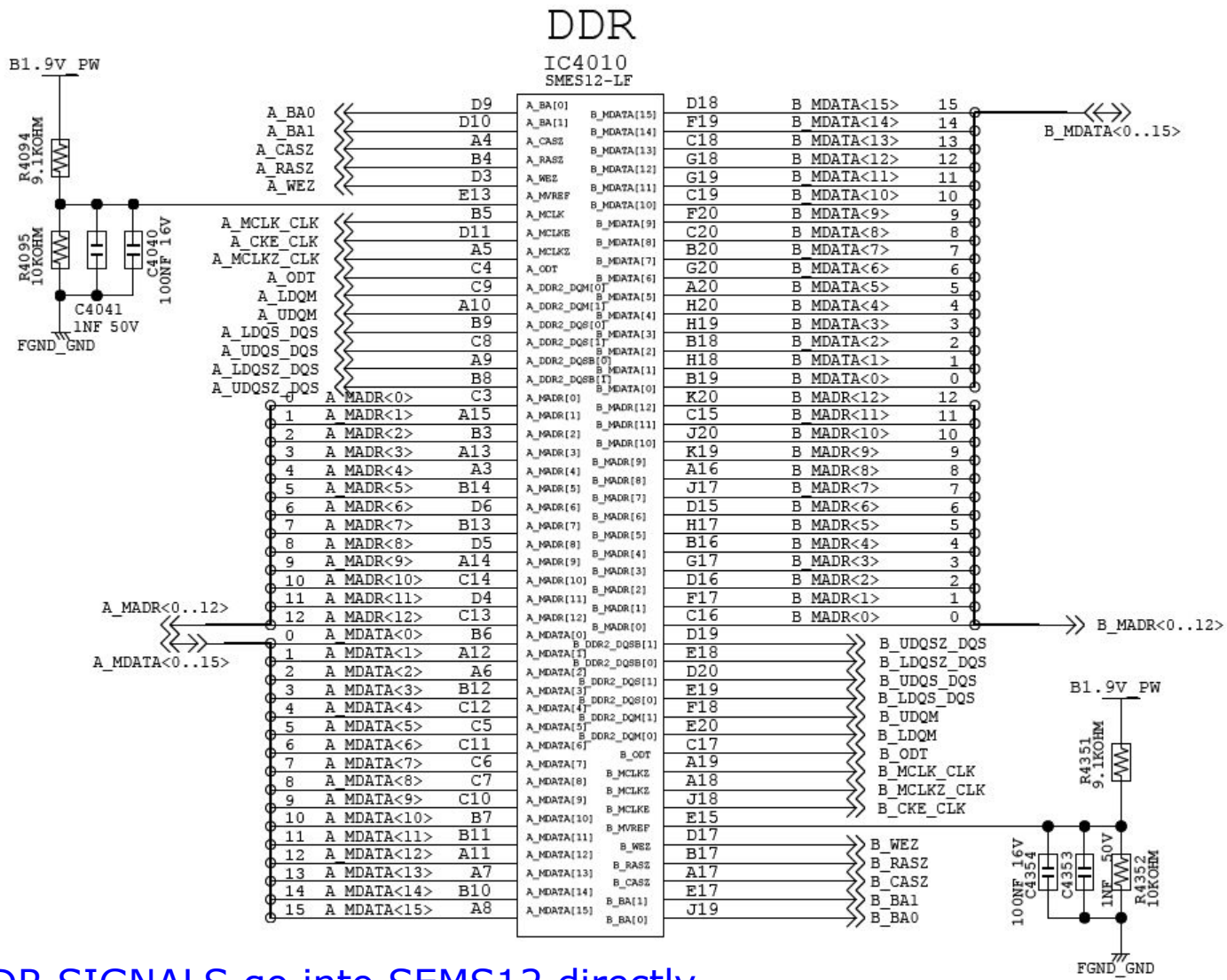

DDR SIGNALS go into SEMS12 directly

4. Signal Flows Information

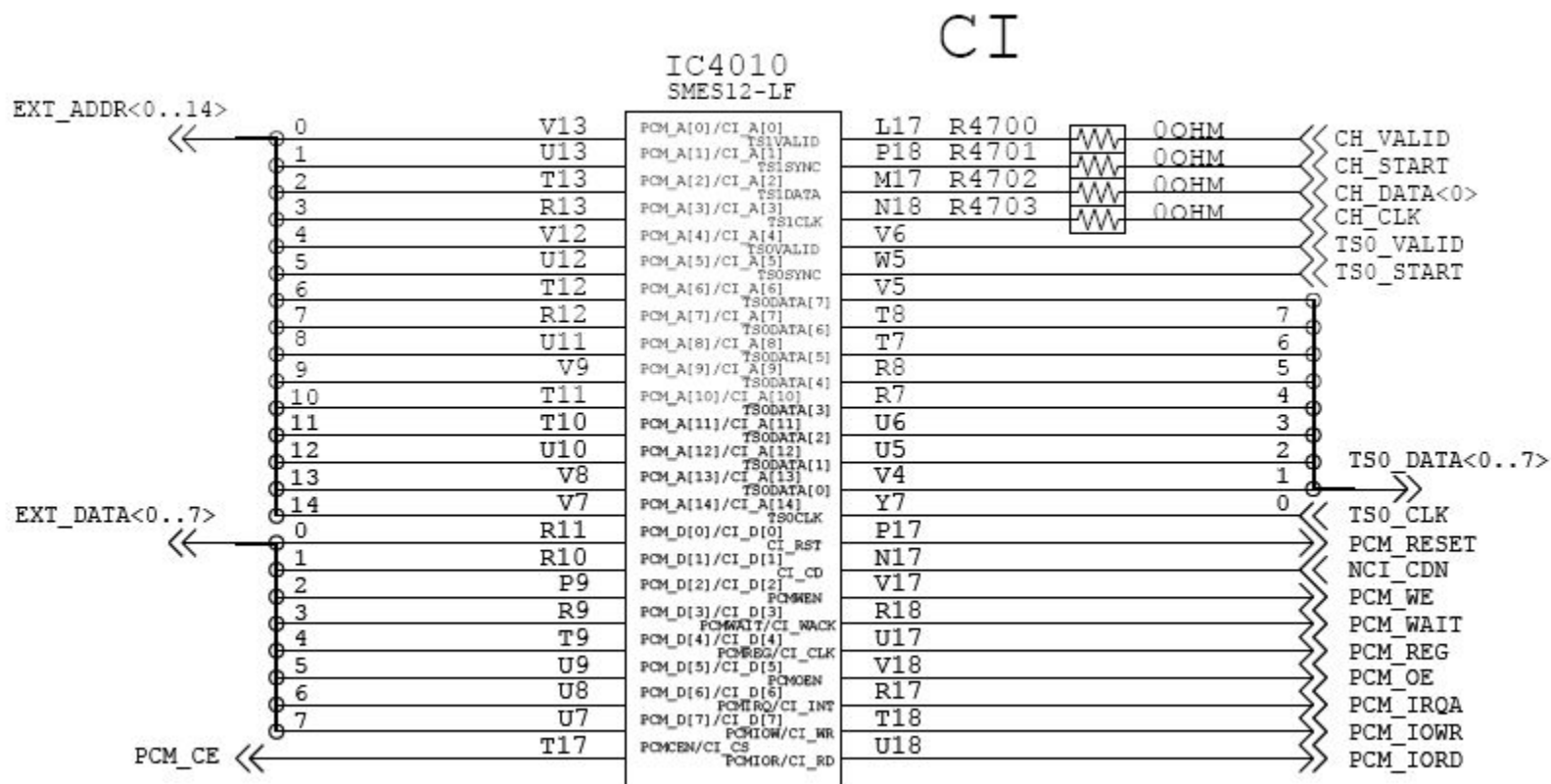

CI SIGNALS go into SEMS12 directly

4. Signal Flows Information

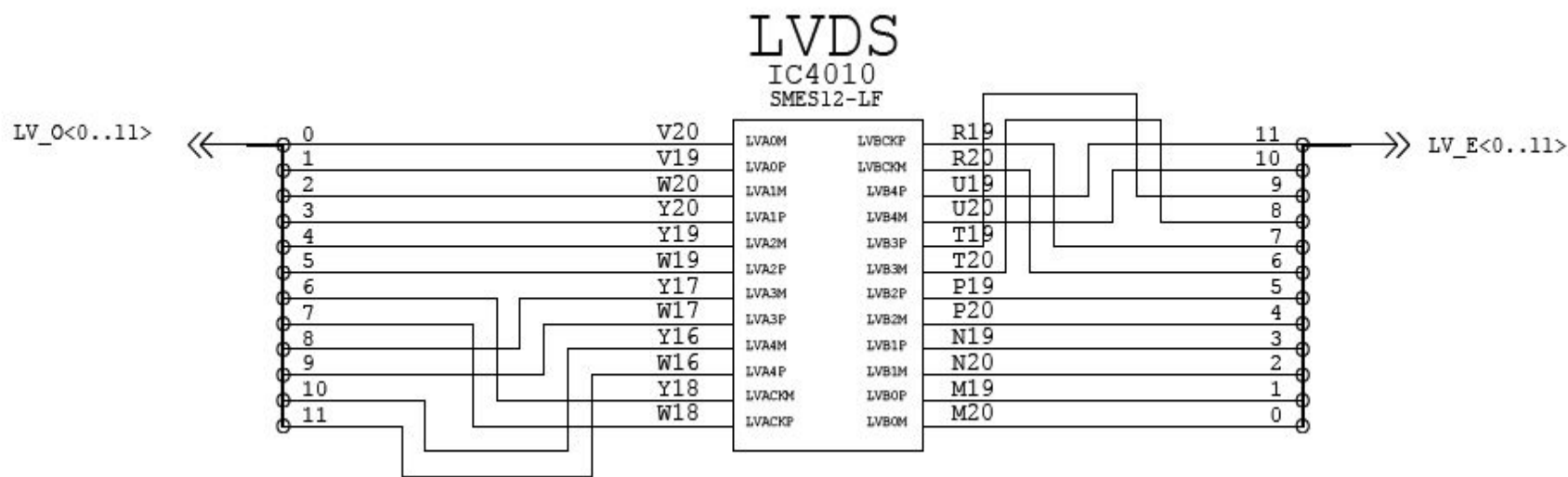

LVDS SIGNALS go into TCON BD directly

SOUND AMP

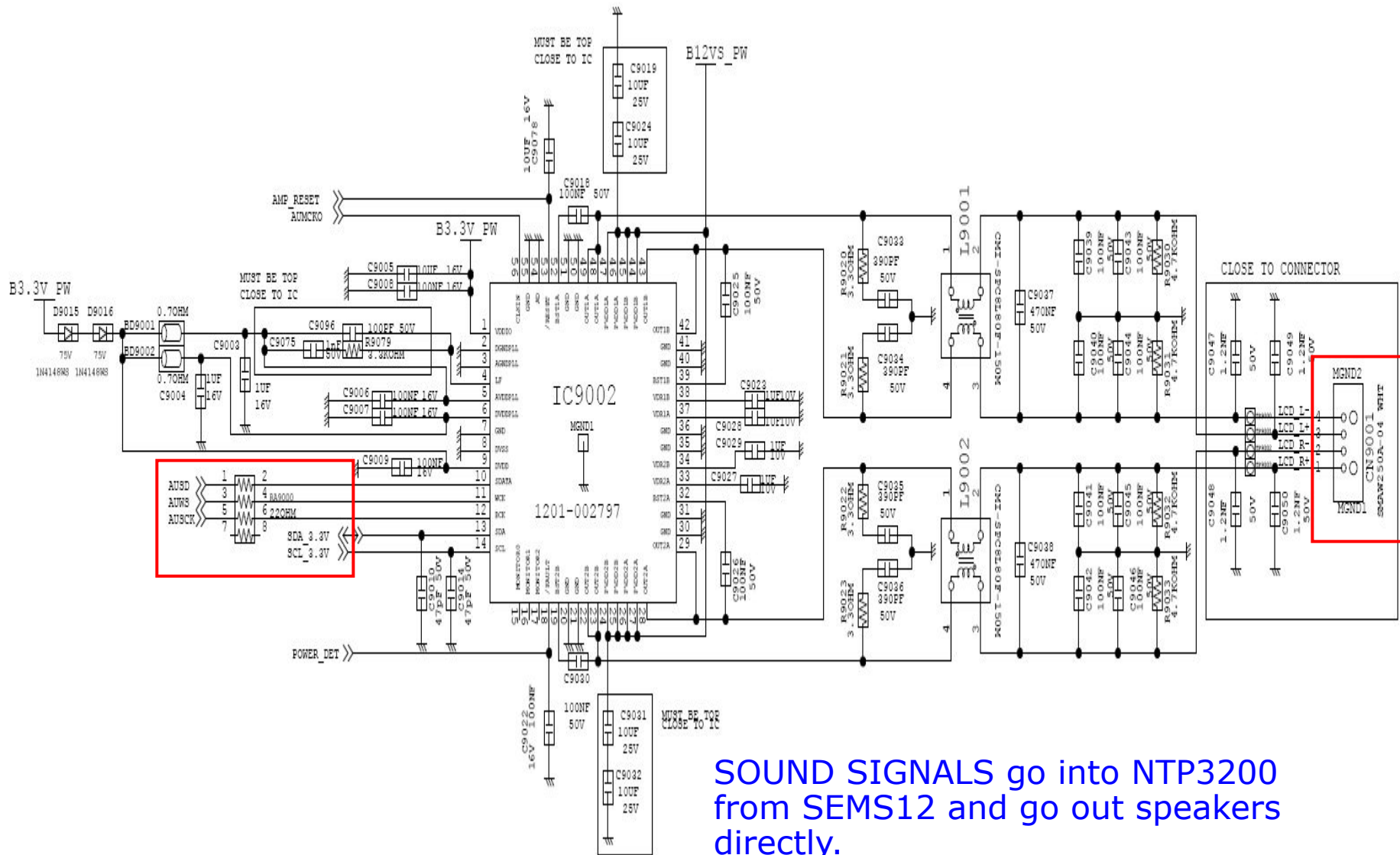

Contents

1. 32" IP Schematic Diagram
2. 37" IP Schematic Diagram
3. 40" IP Schematic Diagram
4. 46" IP Schematic Diagram

5. IP Schematic Diagram : 32"

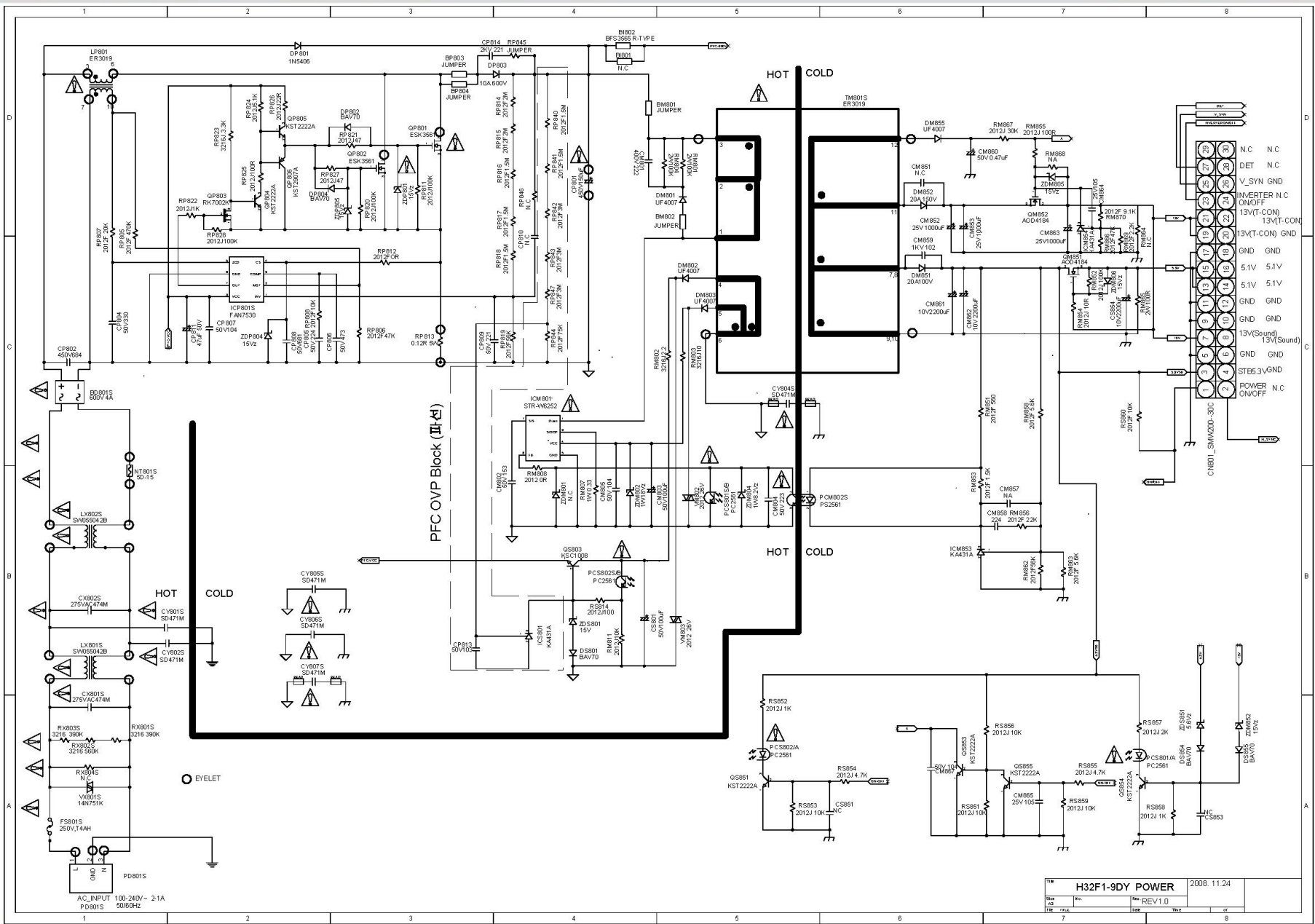

TM	H32F1-9DY POWER	2008.11.24
REV	REV1.0	
DATE		
FILE		
DRG		
TRN		

5. IP Schematic Diagram : 32"

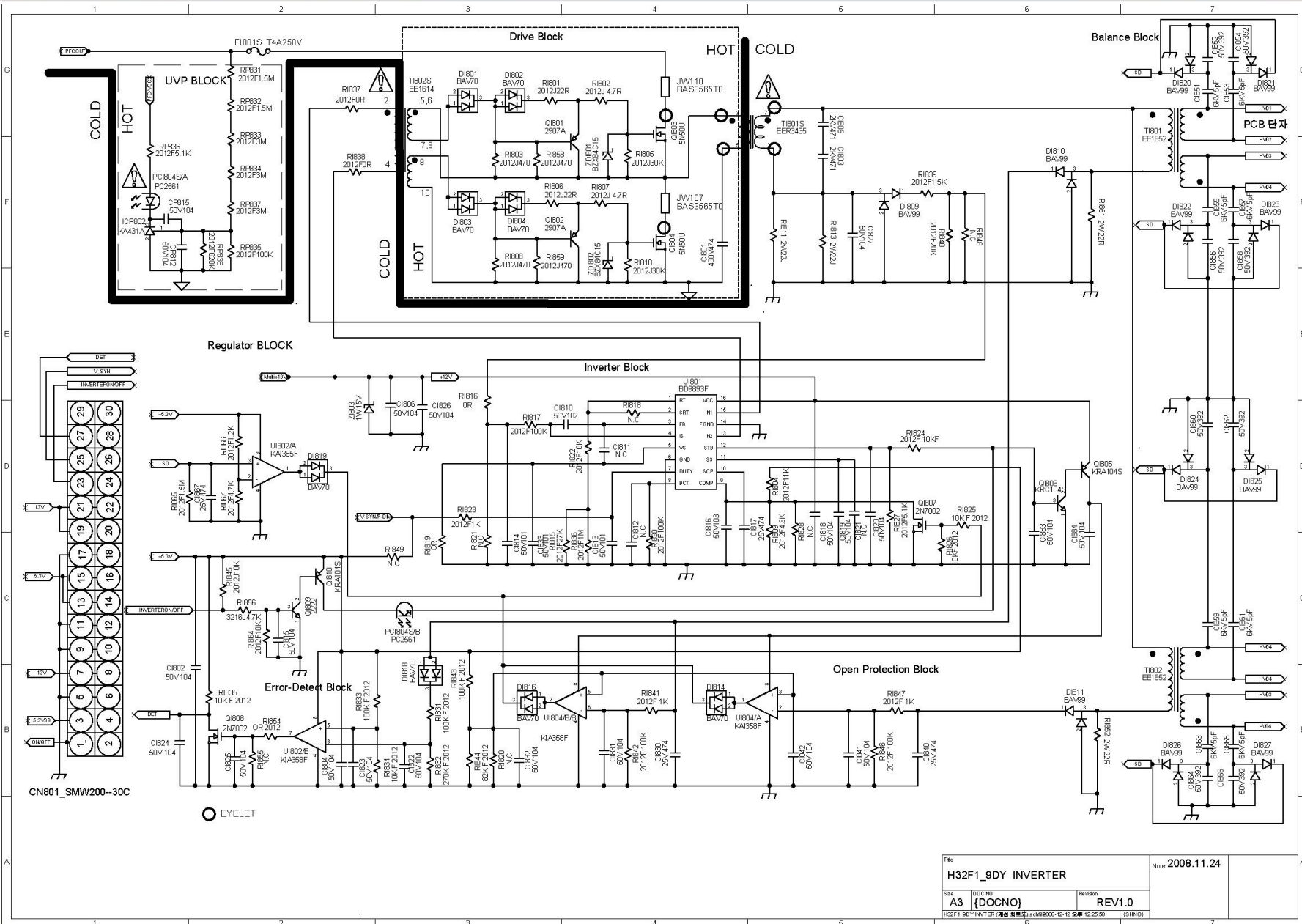

Title		Note 2008.11.24	
H32F1_9DY INVERTER			
Size	Doc No	Revision	
A3 [DOCN0]		REV1.0	
H32F1_9DY INVERTER		[HNM0]	

5. IP Schematic Diagram : 37"

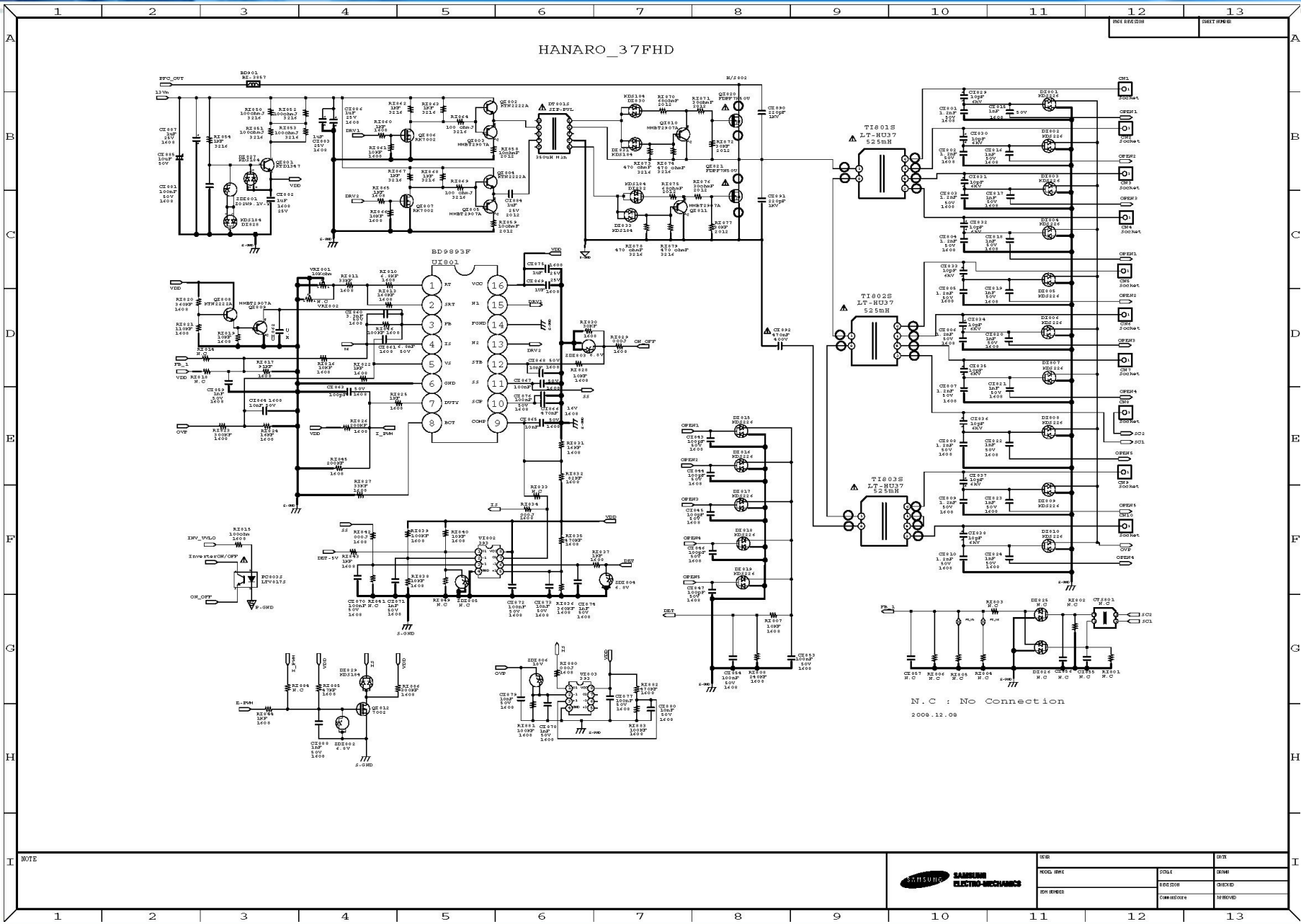

5. IP Schematic Diagram : 40"

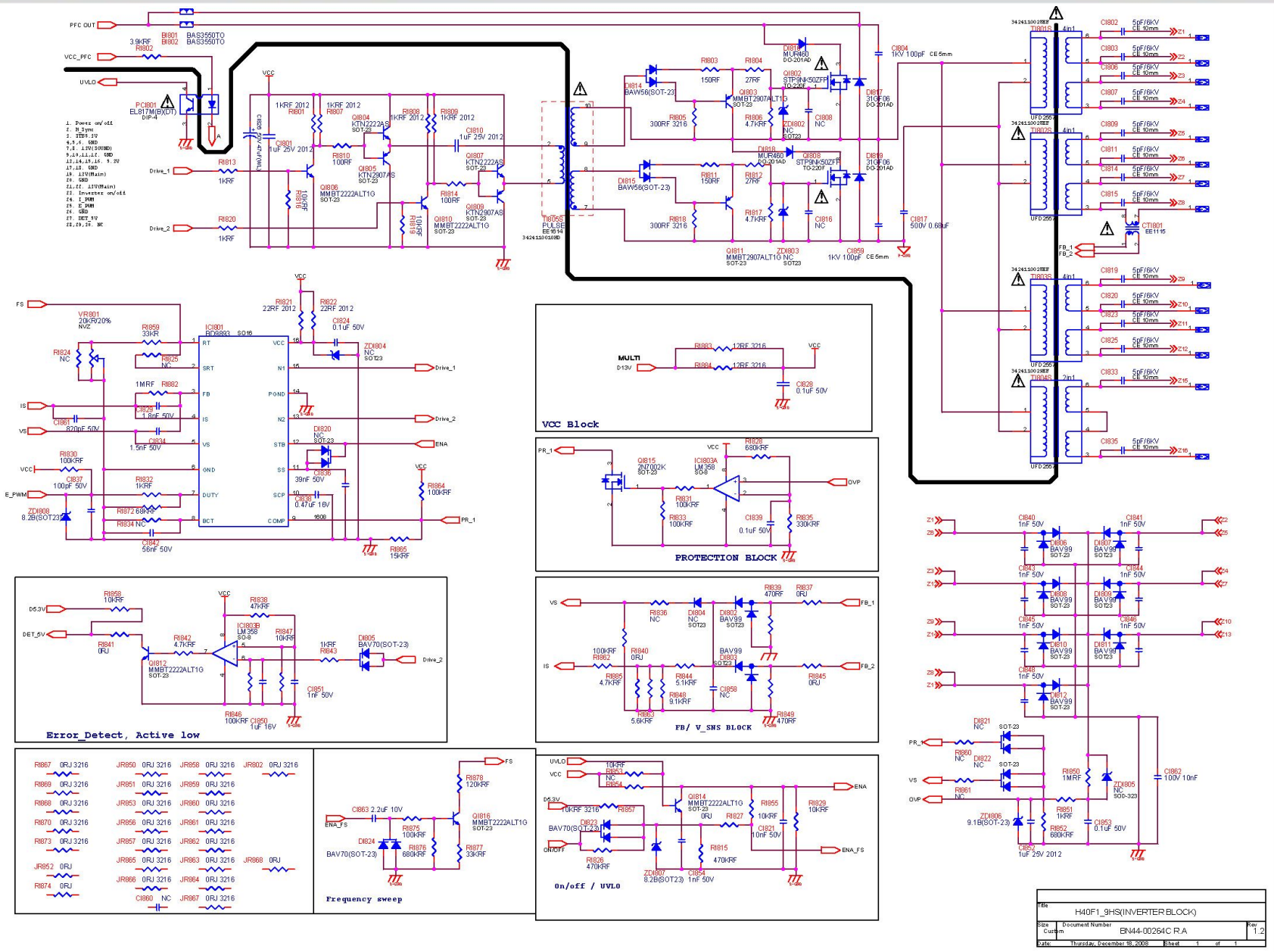

5. IP Schematic Diagram : 46"

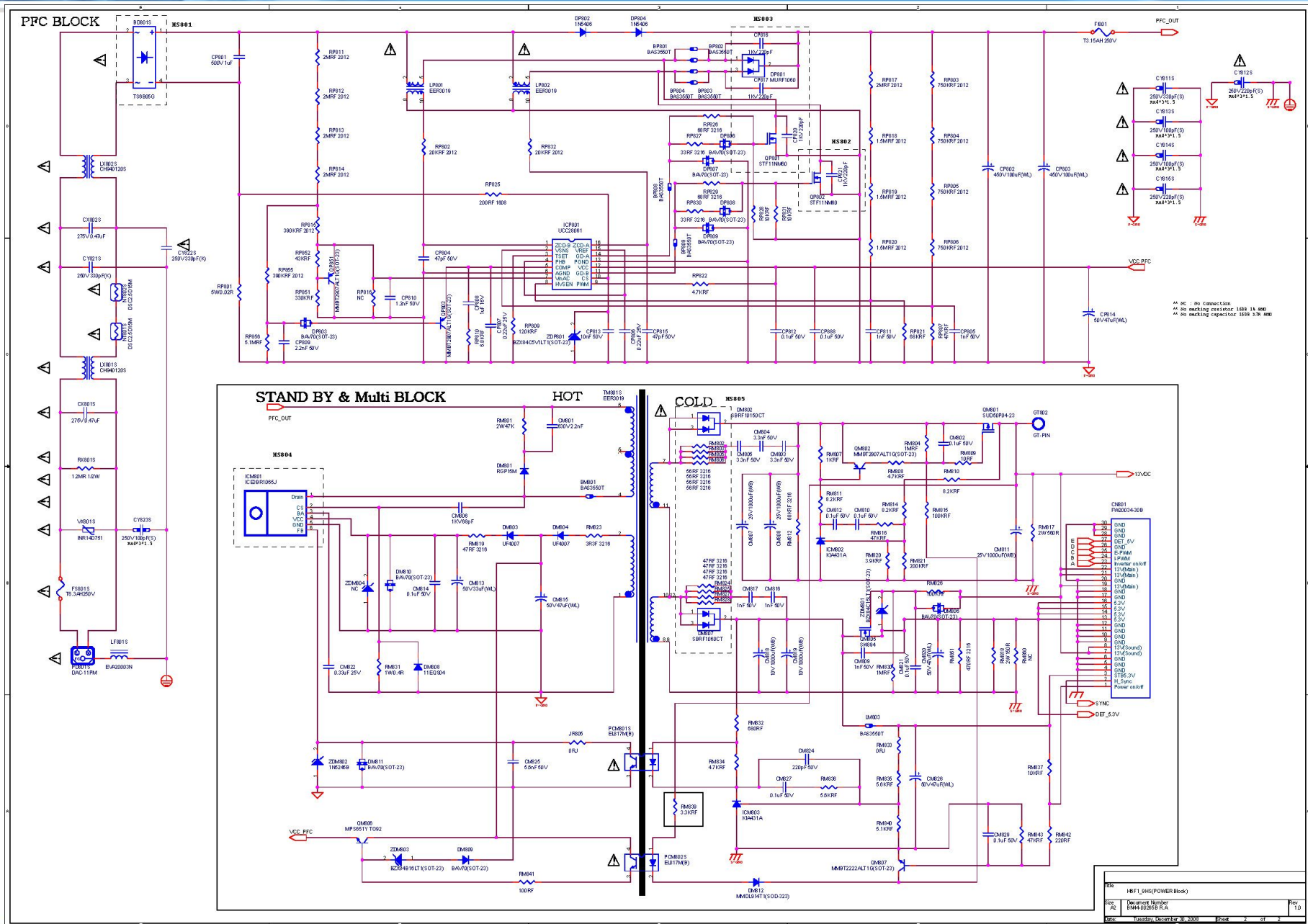

Thank you !