

Before the lecture

Multivariable Process Control System (Flow, Level, Temperature, Pressure) Volume 1/2

**Made by: Sharafatdin Yessirkepov
Checked by: Karl Marx**

Plan

Part 1. Introduction to FLTP

Part 2. Main Units of the trainer

Part 3. Control Units

Part 4. Control Techniques

Part 5. Conclusion

Part 6 Self-Test (No cheating)

Part 7. Lab work

Introduction

How do we control the tank in the field without the manual control? Do we often open the tank and measure the flow rates, Pressures and fluid level by hand in winter ? We are tired by doing so. Let's overcome the problem.

Introduction

It is difficult to control the liquid vessel manually because it is time consuming and requires too much physical work



Introduction (Cont'd)

Therefore, the Process Control System is helpful by controlling the unit parameters even at a high distance automatically.

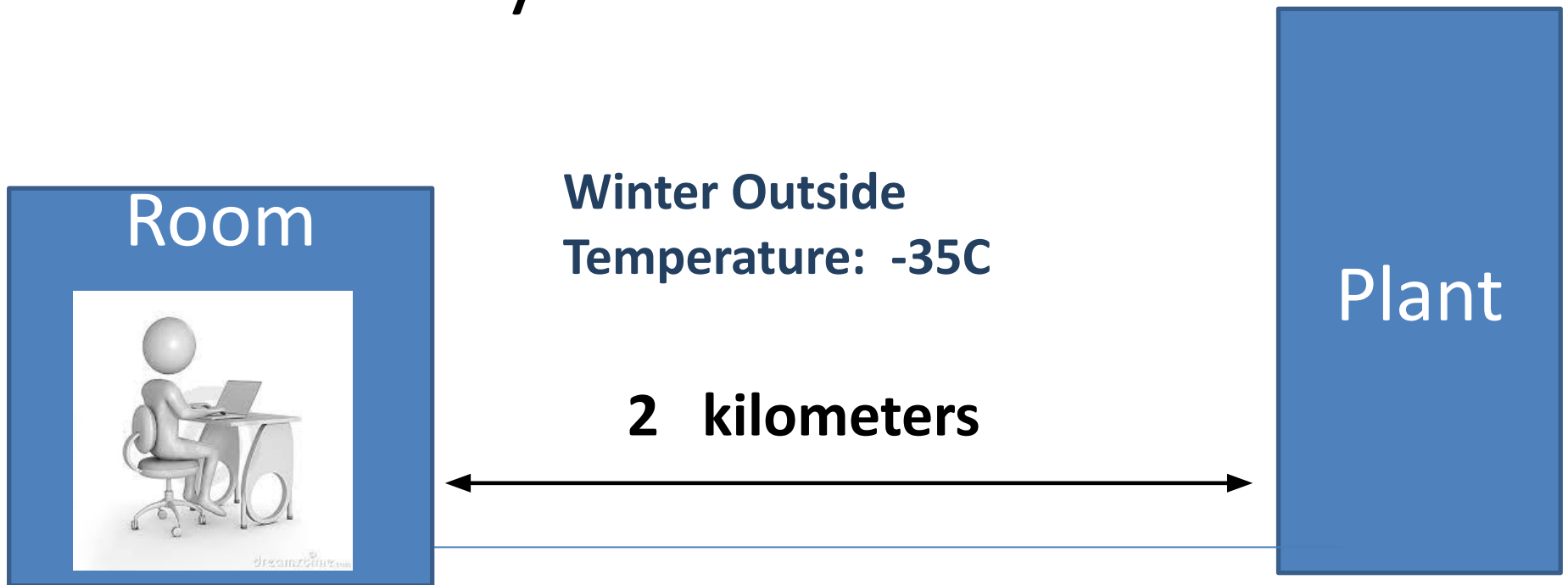

Introduction Cont'd

Multivariable Process Control System can control the flow rate, level, Pressure and Temperature of the fluid inside the vessel



External Process Unit FLTP-U/EV

Basic panel

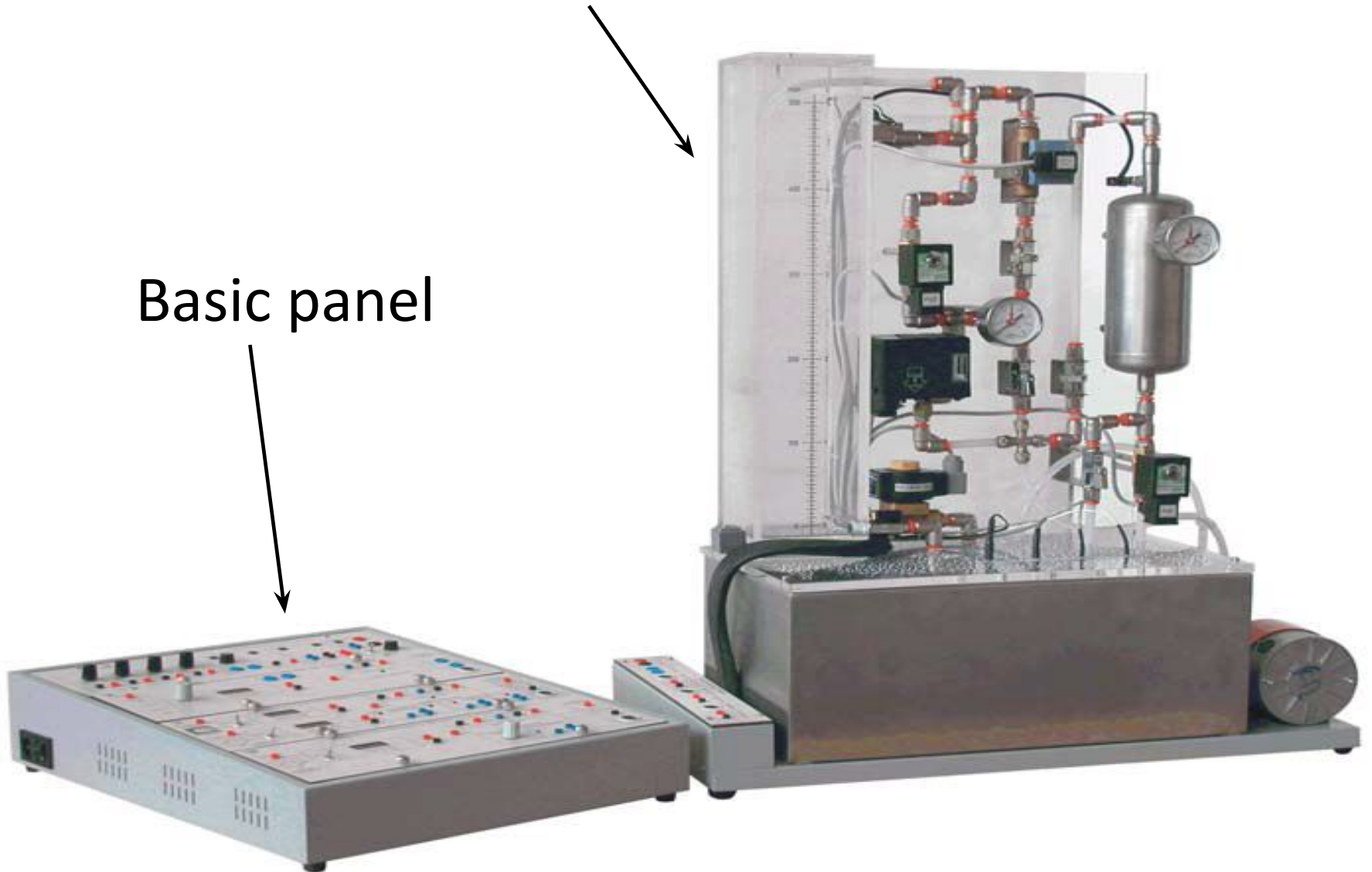

1) Main Units of the trainer FLTP

- 1) Power supply unit mod. FLTP-A/EV
- 2) Module for temperature control mod. FLTP-B/EV
- 3) Module for level and flow-rate control mod. FLTP-C/EV
- 4) Module for pressure control mod. FLTP-D/EV
- 5) Process units mod. FLTP-U/EV

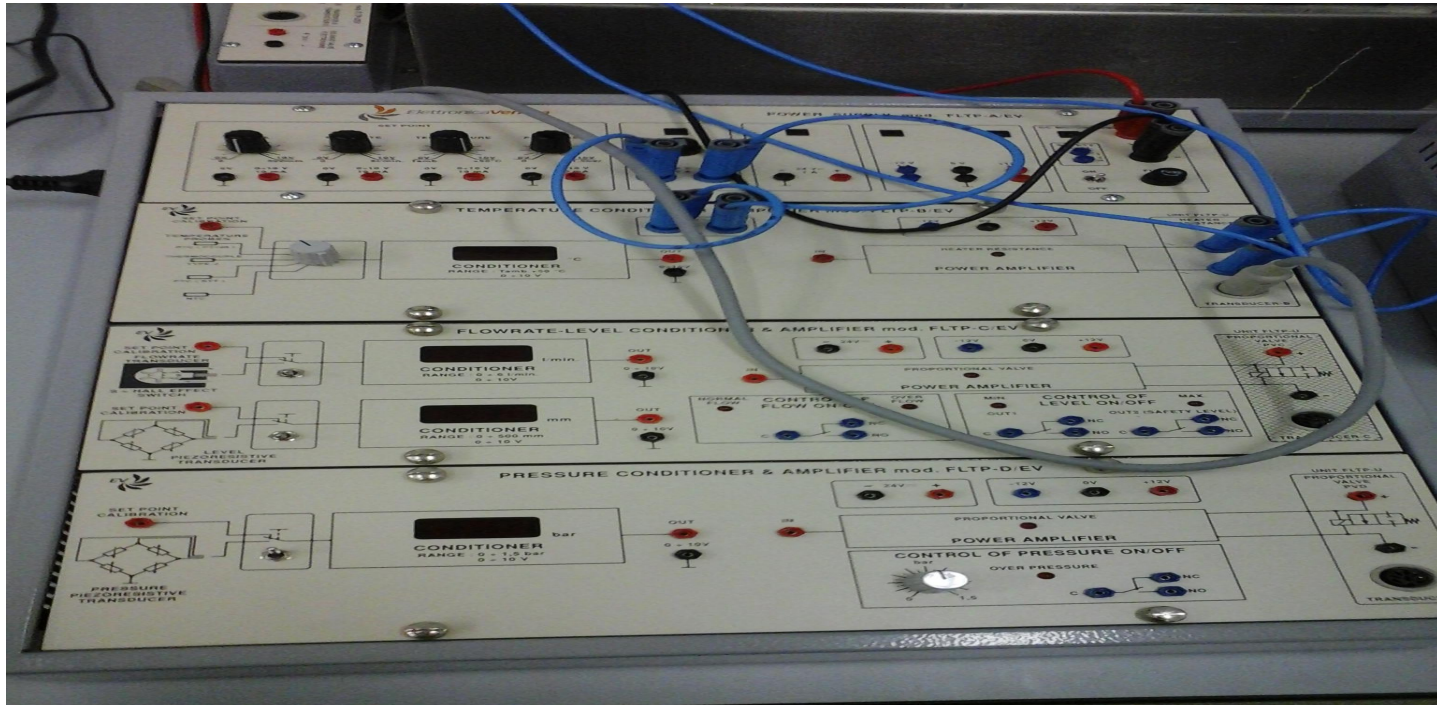

1.1 Power Supply Unit (FLTP-A/EV)

Consists of 5 windows

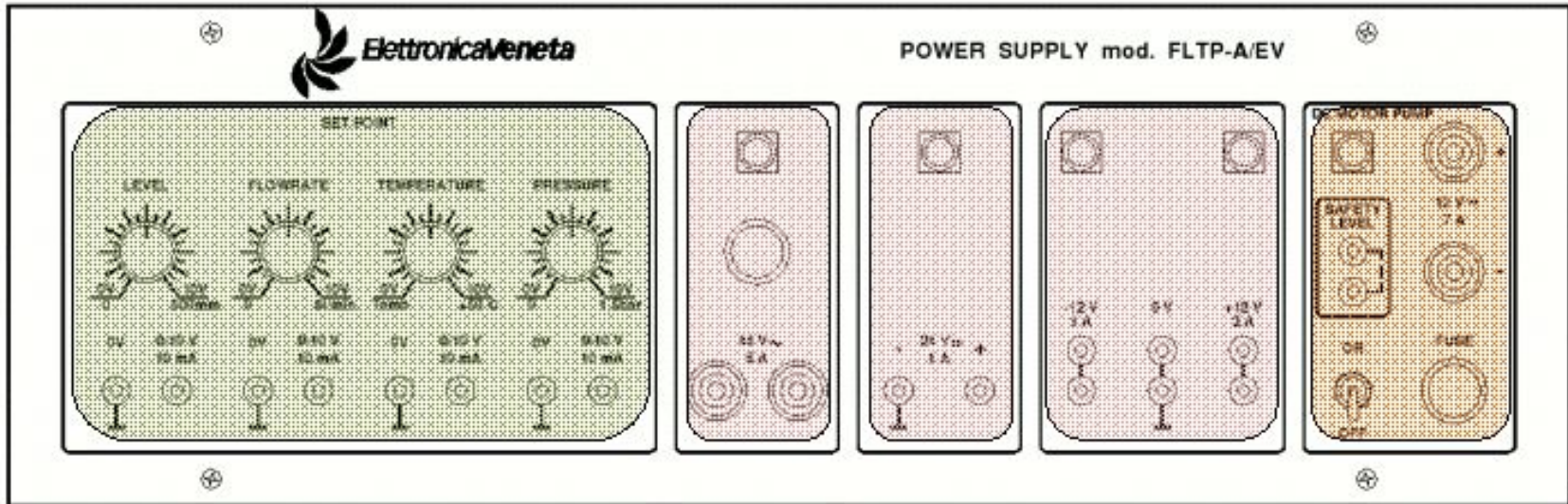

1st window has 4 potentiometers of the process variables (Level, Flow rate, Temperature and Pressure)

2nd 3rd and 4th windows are the switches of the other units (Temperature, Level and Pressure).

5th window works with the pump

1.2 Module for temperature control mod. FLTP-B/EV

- Has Conditioner on the left side
- Has Amplifier on the right side
- Temperature unit requires these voltages:
-12V; 0V; +12V and 48V

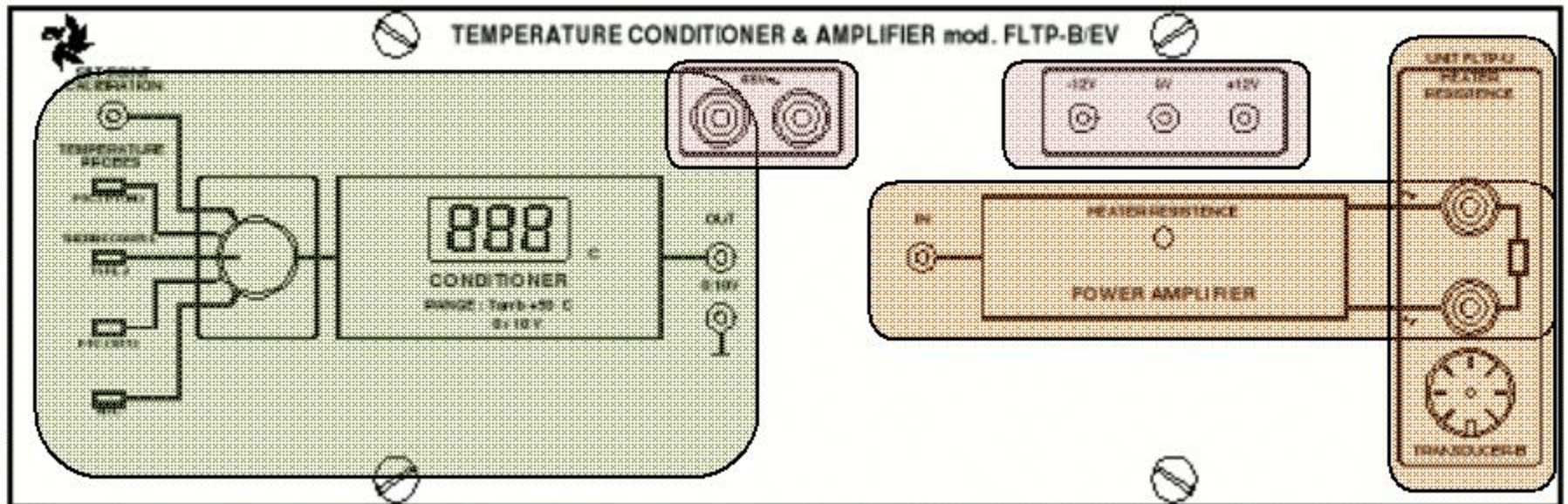

Question

- Which kind of thermocouples do you know?

1.2.1 Types of thermal sensors

For FLTP Conditioner

- Thermocouple J
- STT – Smart Temp. Transmitter
- NTC – Negative Temperature Coefficient Thermistor
- Pt100 with more accuracy

In general

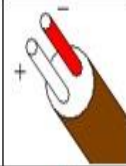
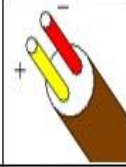
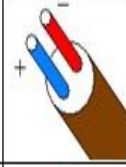
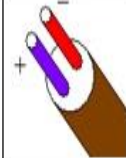
Type	Material		Color Code	Range (°C)	
	Positive Wire	Negative Wire		Minimum	Maximum
J	Iron	Constantan		0	750
K	Chromel	Alumel		-200	1250
T	Copper	Constantan		-200	350
E	Chromel	Constantan		-200	900

1.2.1 Module for temperature control mod. FLTP-B/EV

- Has Conditioner on the left side and deals with thermocouples.
- Conditioner has 5 inputs and 1 output

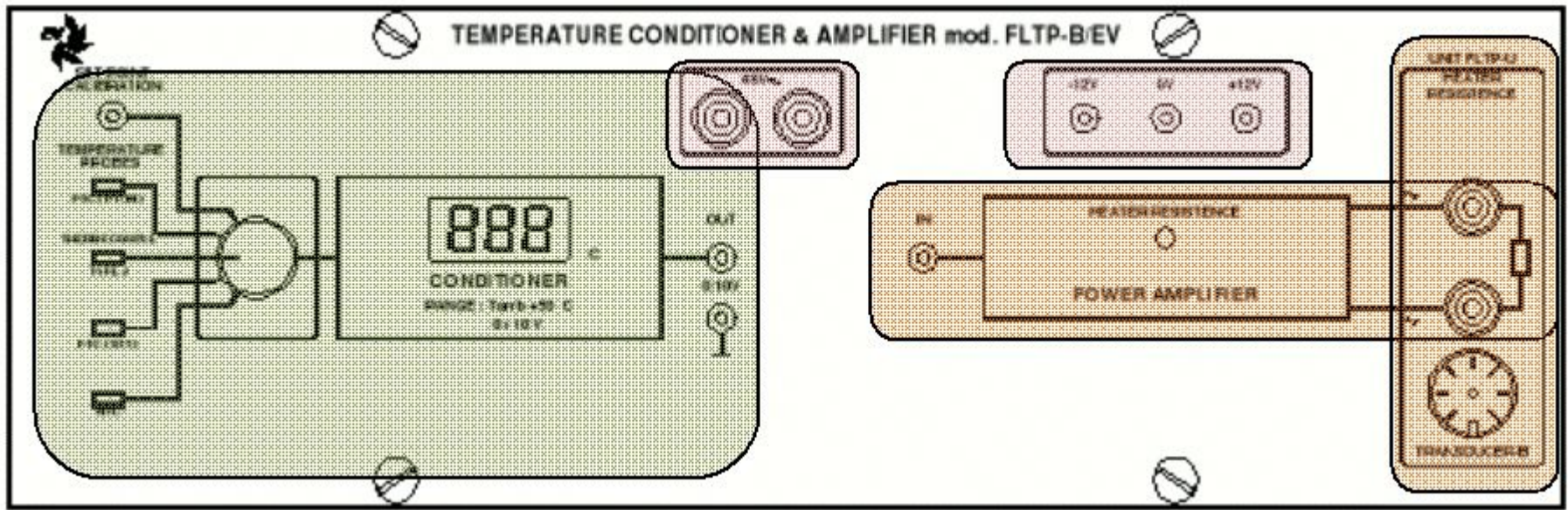

Question.

- What is amplifier?

1.2.2 Amplifier (Brief explanation)

- **Amplifier** – modulates the output stronger than input signal

For example:

Input voltage is 3V and output is 5V after amplification

- Has 1 input and 1 output signal to the heating resistor

1.3. Flow Rate- Level Control (FLTP-C/EV)

- Has 2 conditioners, 1 amplifier and 2 controllers
- Flow rates deal with the top window
- Level measurements are at the bottom
- Has the voltage requirements:

-12V; 0V; +12V and 48V

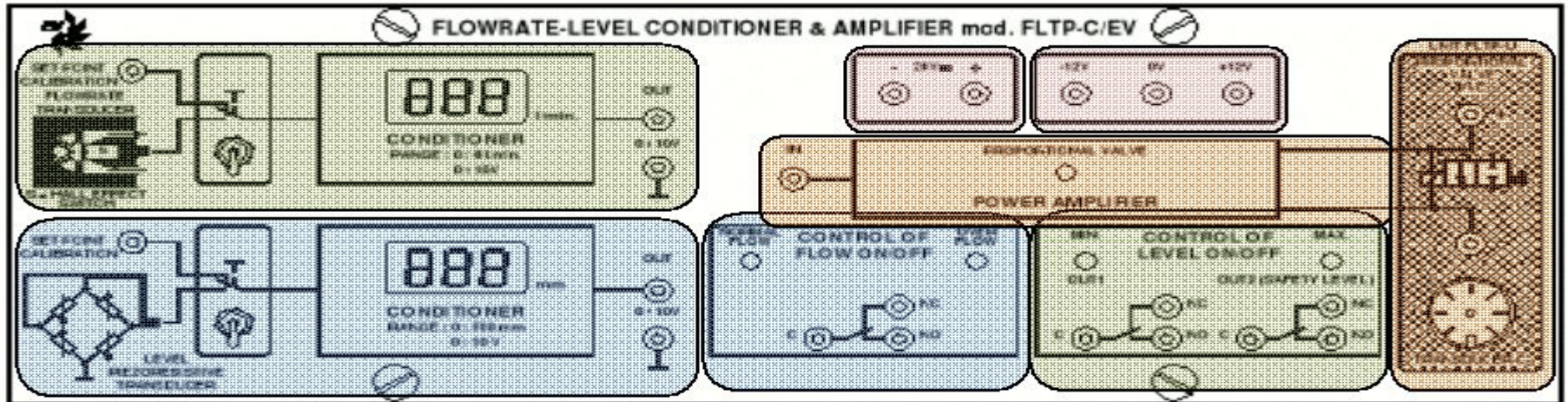

1.3.1 Flow Rate Control

- Measures the flow rate with a paddle wheel
- Unit : l/min
- Has 2 inputs and 1 Output
- Has a switch

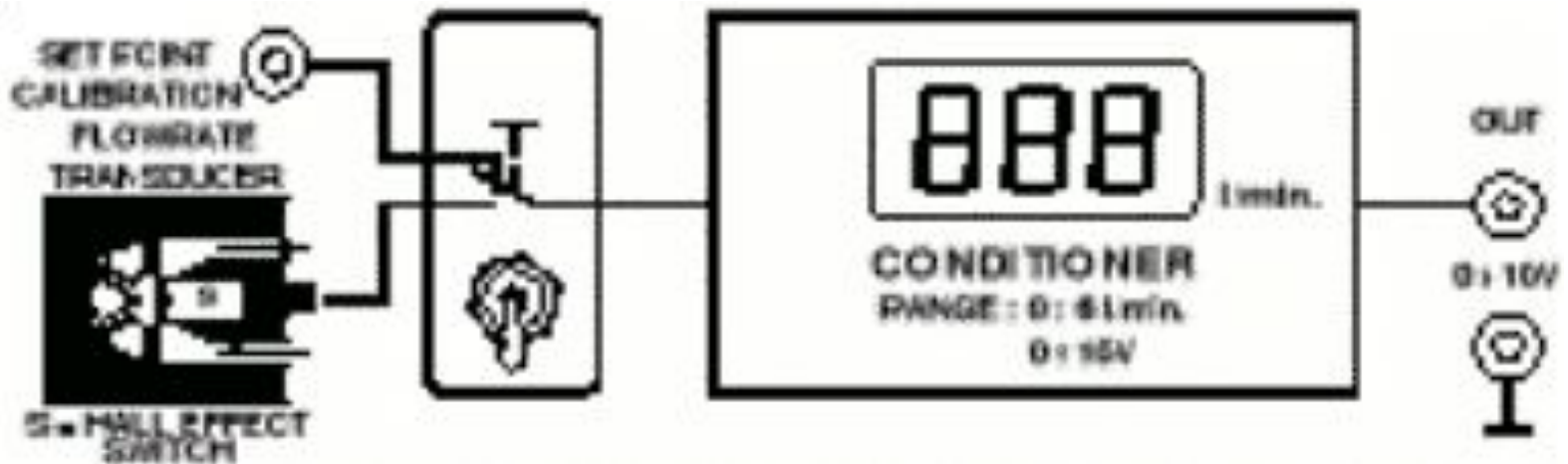

1.3.2 Level Control

- Shows the level of the tank
- Measured with piezometric sensor

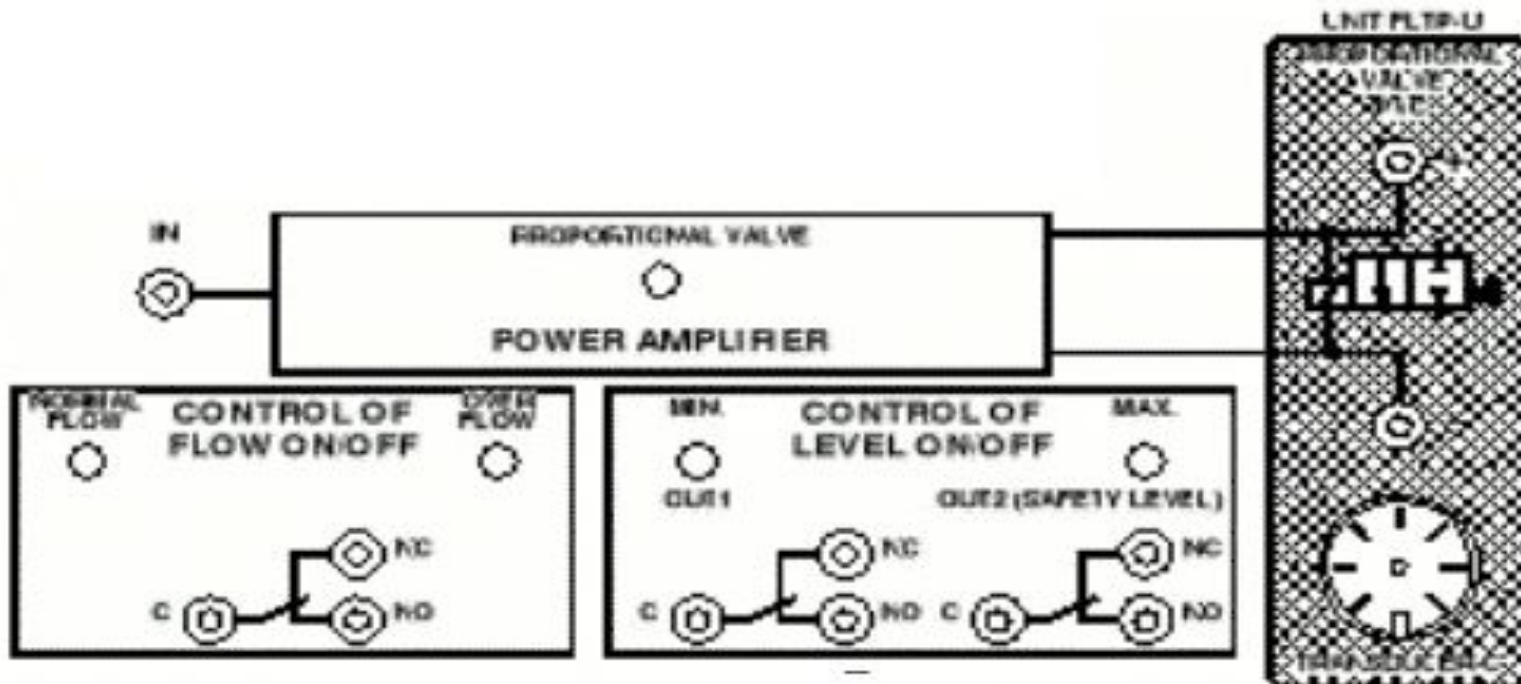

1.4 Pressure Unit (FLTP-D/EV)

- Has signal conditioner and amplifier
- Pressure is measured in bars.
- Has 1 input and 1 output controlled with the PVD valve
- Managed with the pump

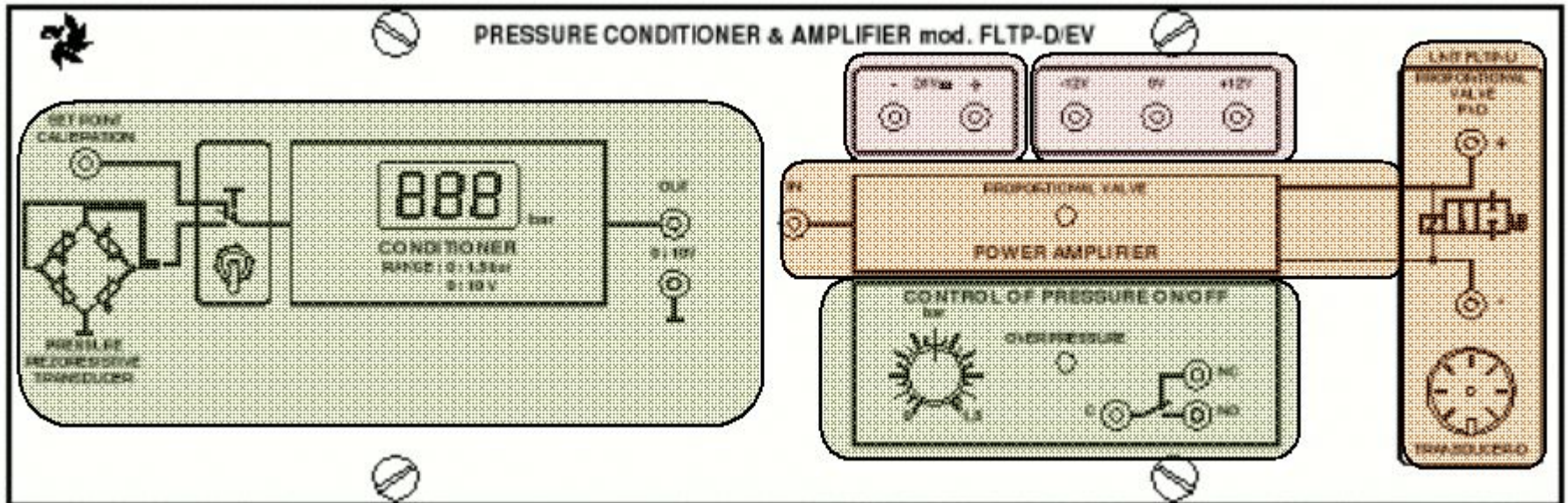

1.5. External Unit (FLTP-U/EV)

- Has plexiglass panel
- Has 3 tanks:
 - 1) 25litres stainless steel at the bottom;
 - 2) 5liters vertical plexiglass;
 - 3) 1litre vertical steel tank
- Has a recirculation pump
- Manual Control Valves
- Water Heater with Resistor
- 2 Proportional Valves
- 2 Pressure gauges
- On/ Off Solenoid Valve
- Process variable Sensors
- 1 glass mercury thermometer

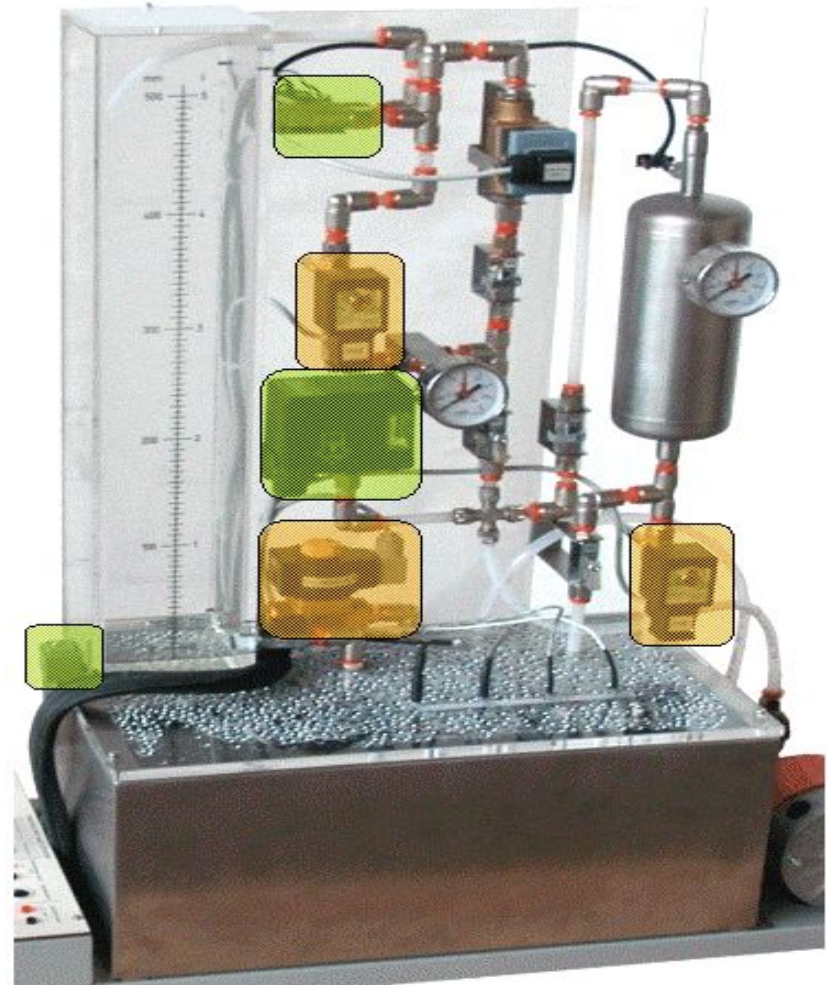

1.5. External Unit (FLTP-U/EV)

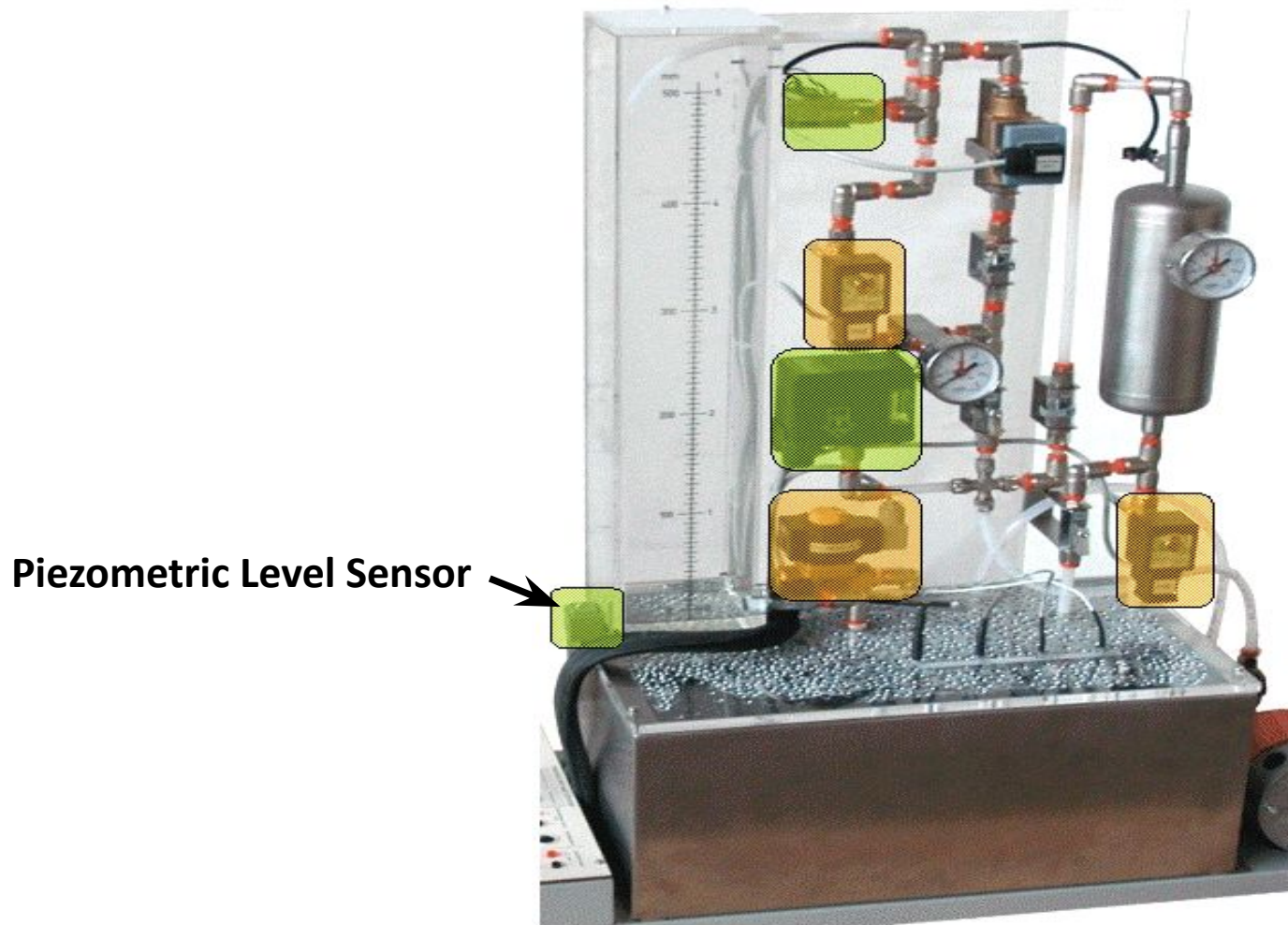

1.5. External Unit (FLTP-U/EV)

Thermostat (0-50C)

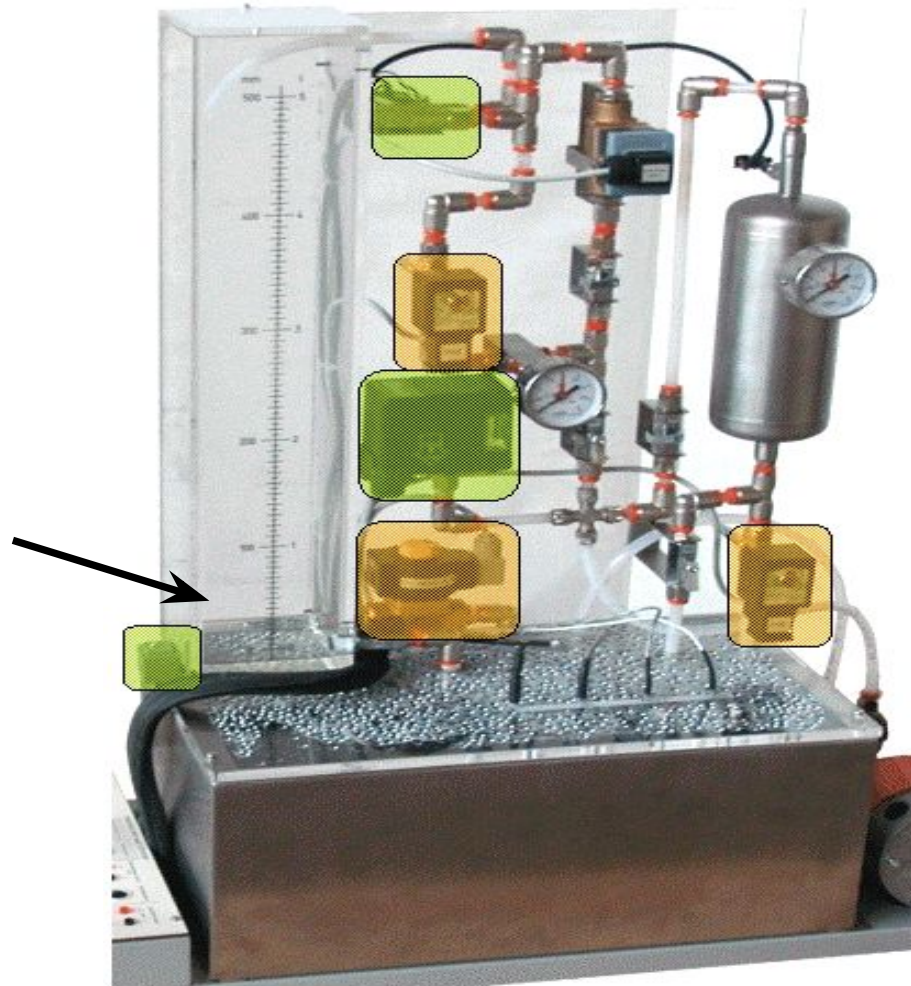

1.5. External Unit (FLTP-U/EV)

On/ Off Exhaust
Solenoid Valve

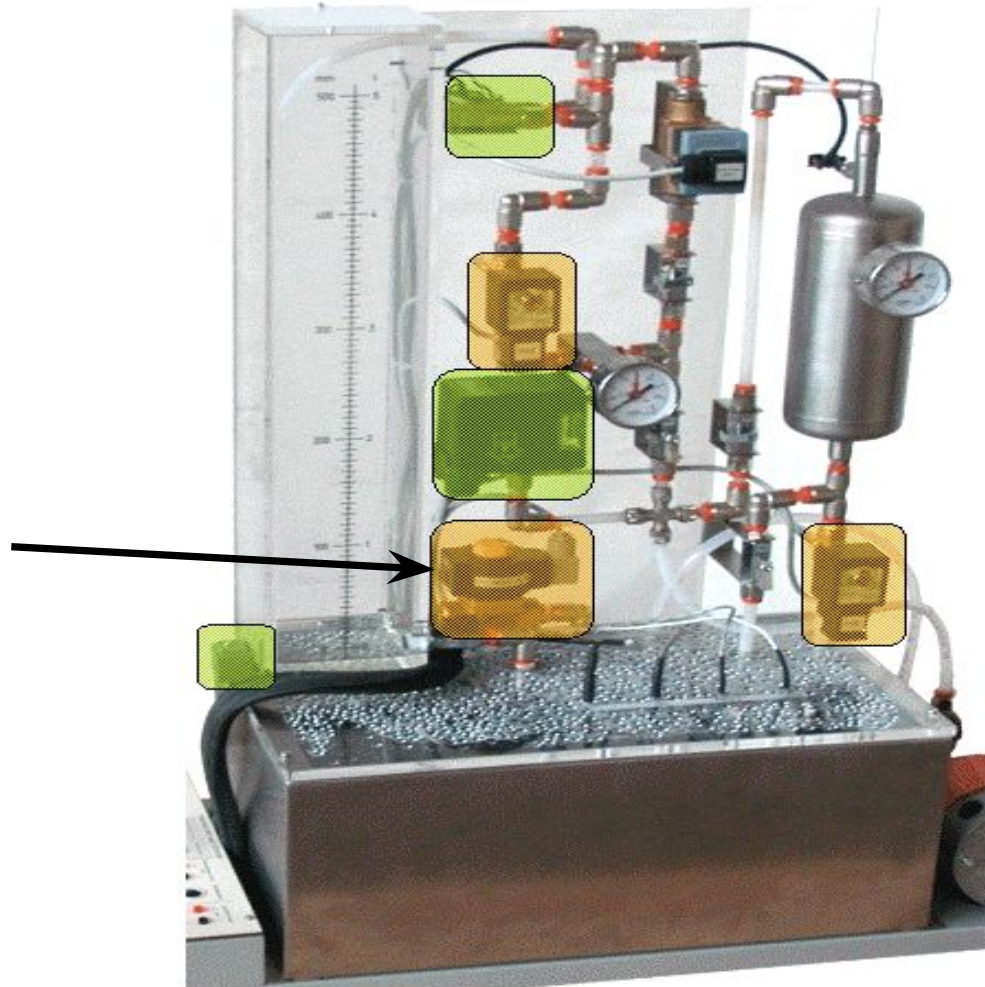

1.5. External Unit (FLTP-U/EV)

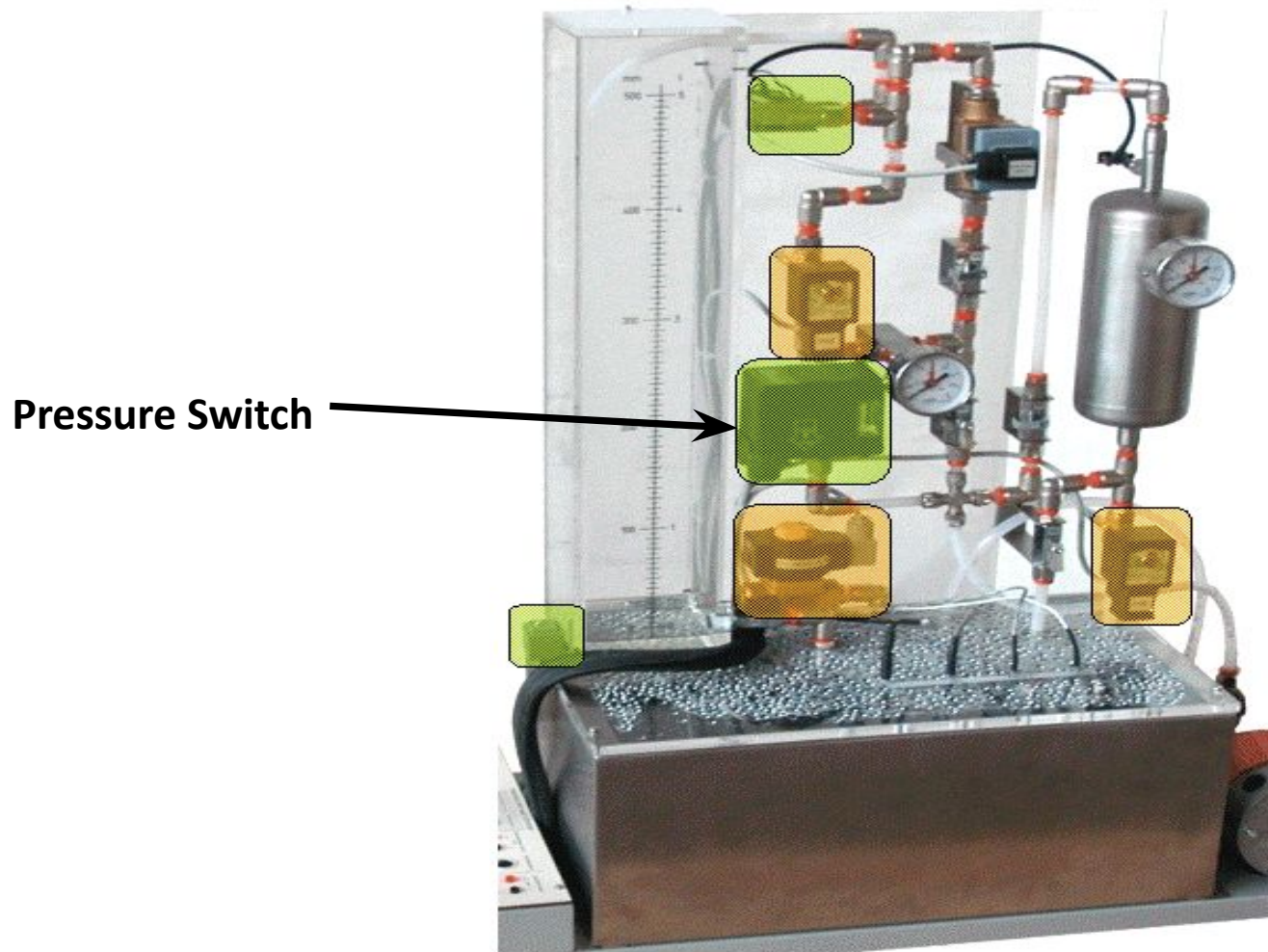

1.5. External Unit (FLTP-U/EV)

PVC Proportional Valve

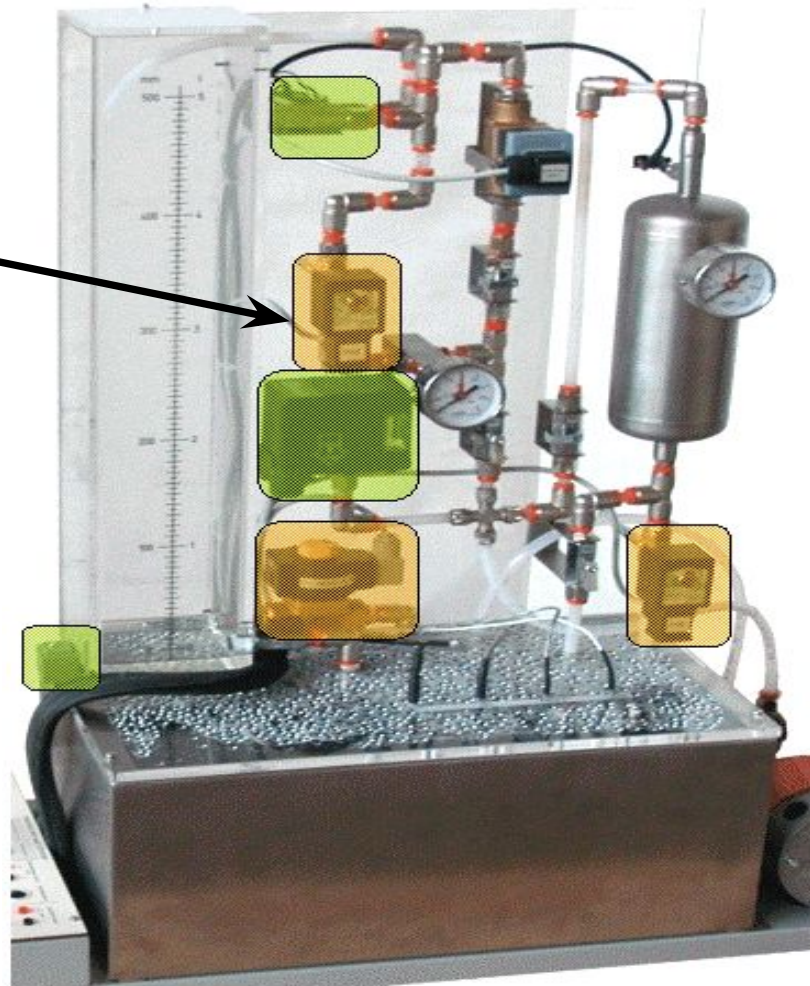

1.5. External Unit (FLTP-U/EV)

Paddle Wheel
Flow meter

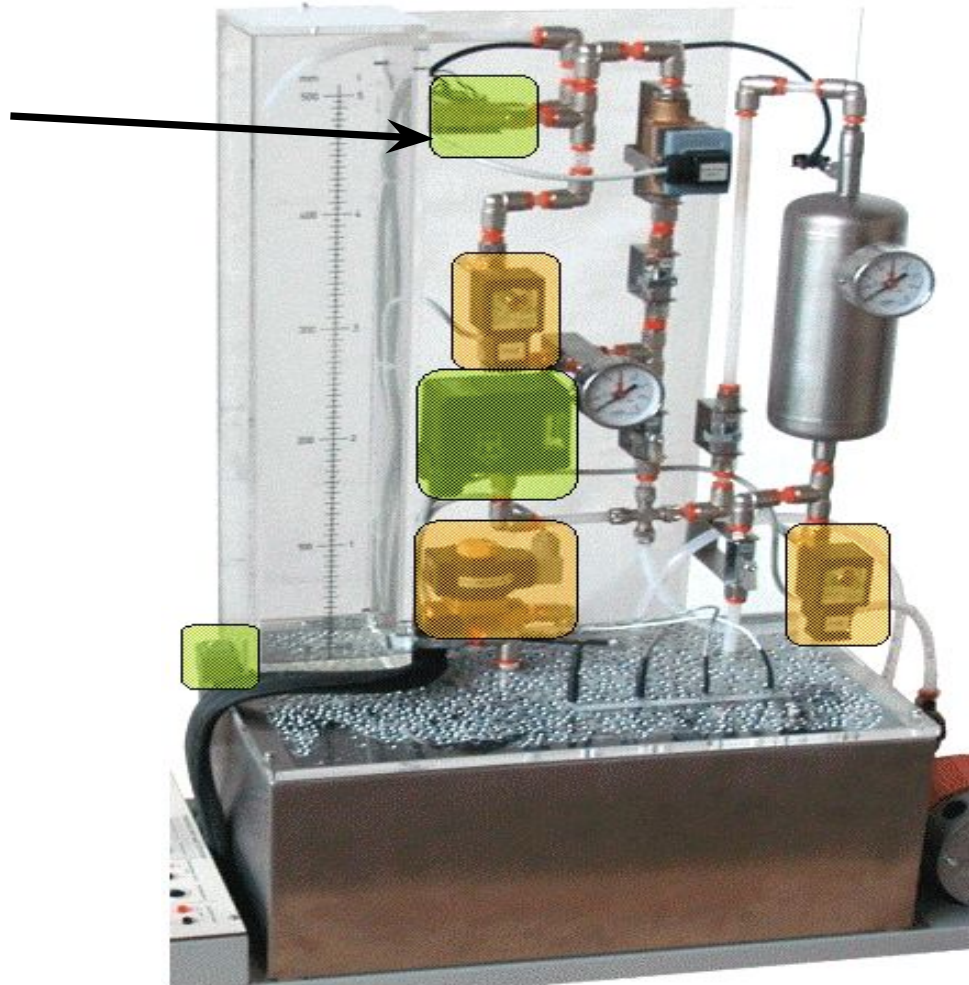

Paddle wheel flow measurement

- Has a magnet in one of the paddles
- Hall effect is represented by magnetic vibration as the wheel rotates quickly
- $Q = \text{Number of pulse}(\text{litre}) / \text{time}(\text{sec})$

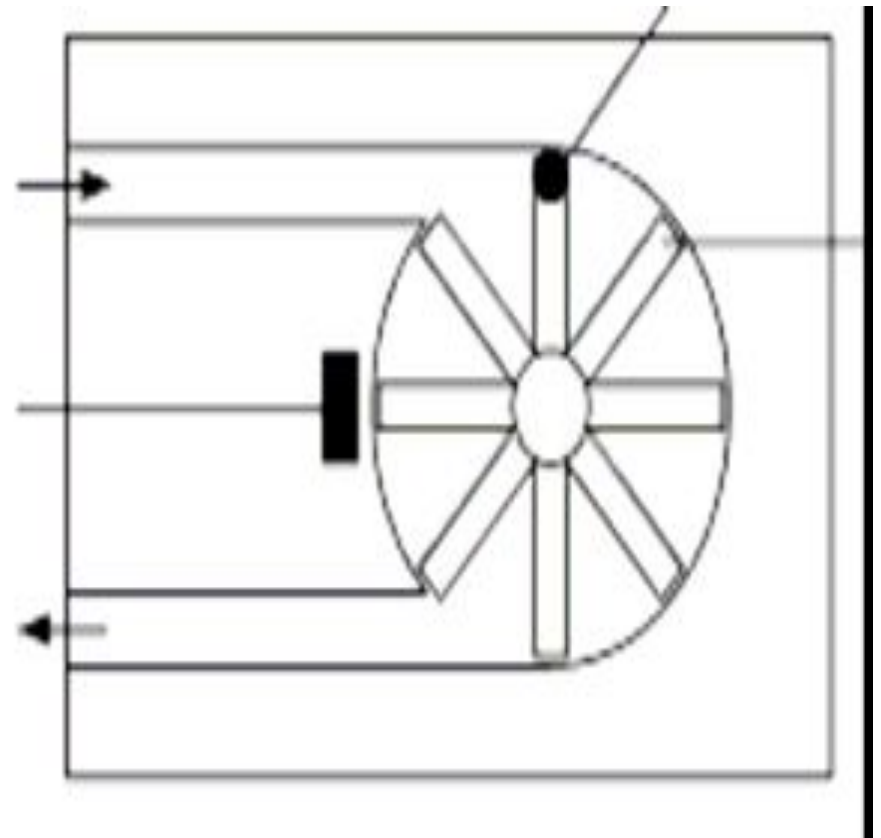

1.5. External Unit (FLTP-U/EV)

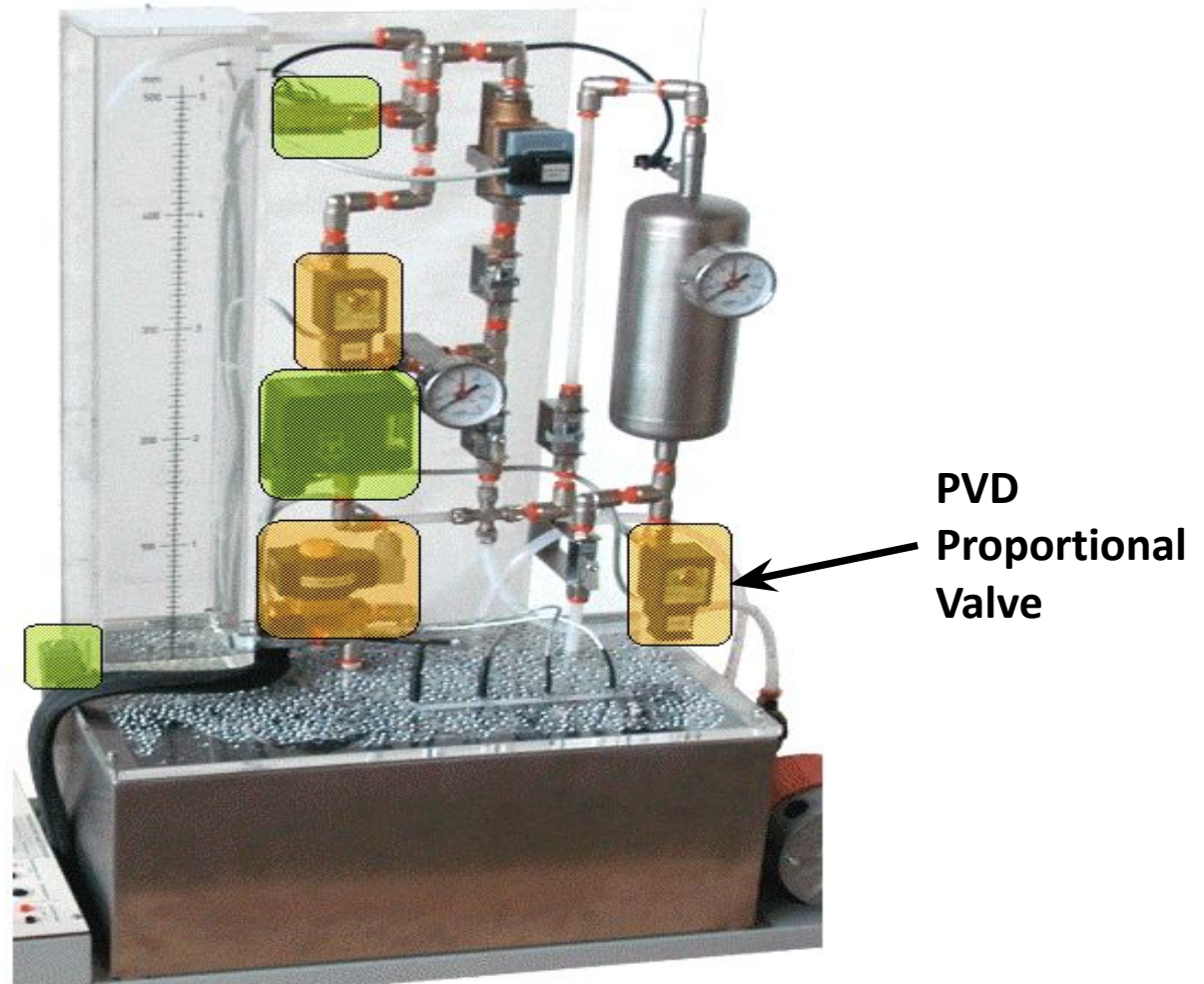

1.5. External Unit (FLTP-U/EV)

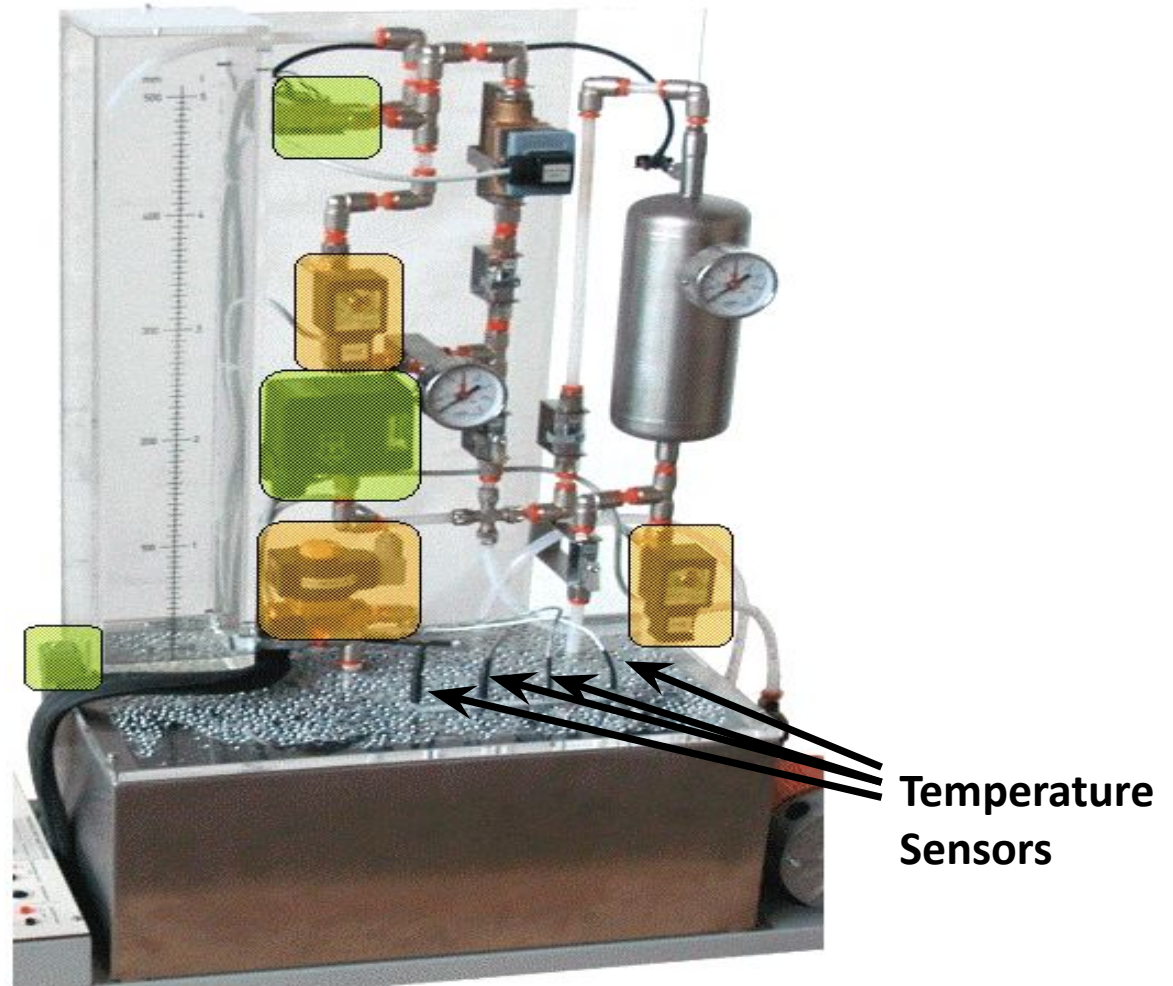

1.5. External Unit (FLTP-U/EV)

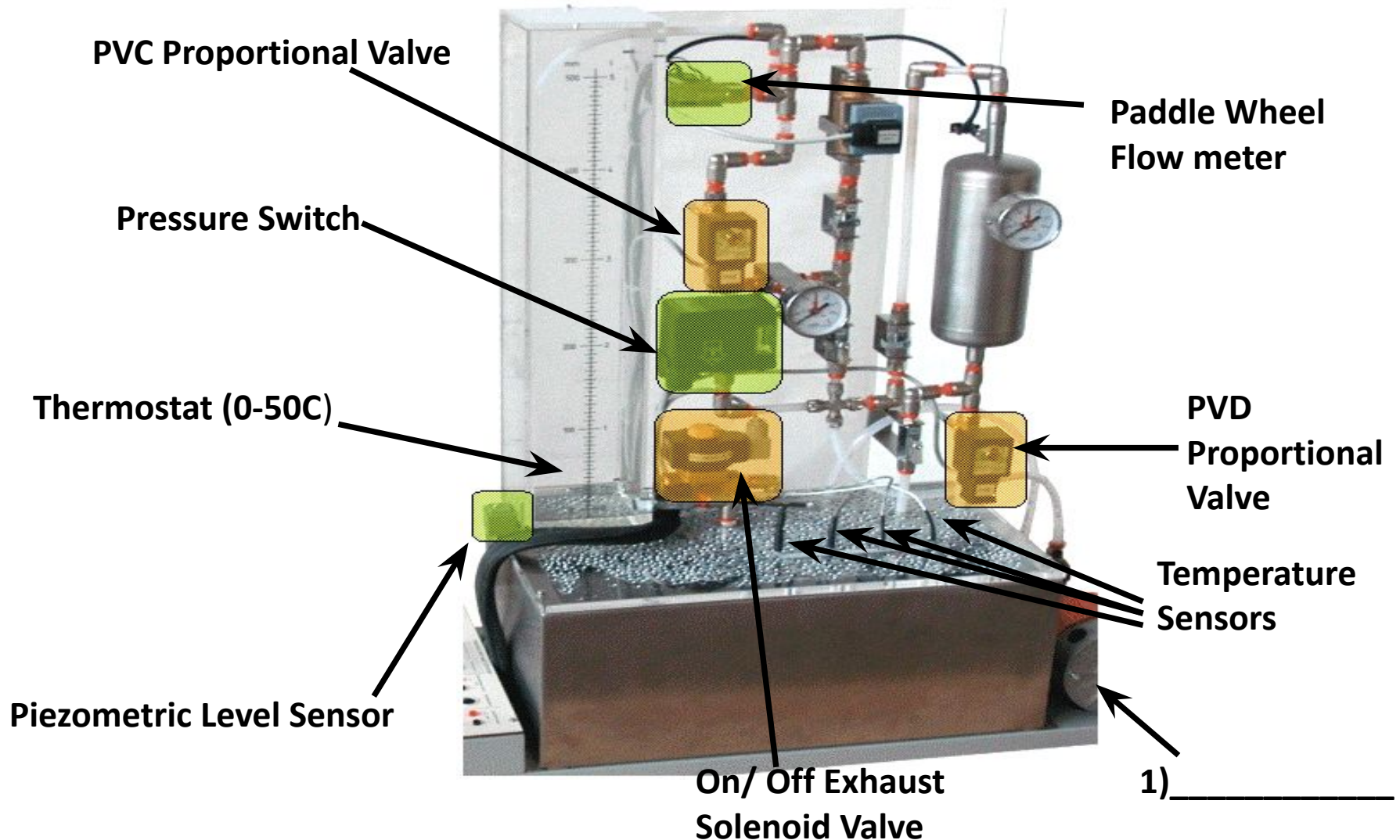

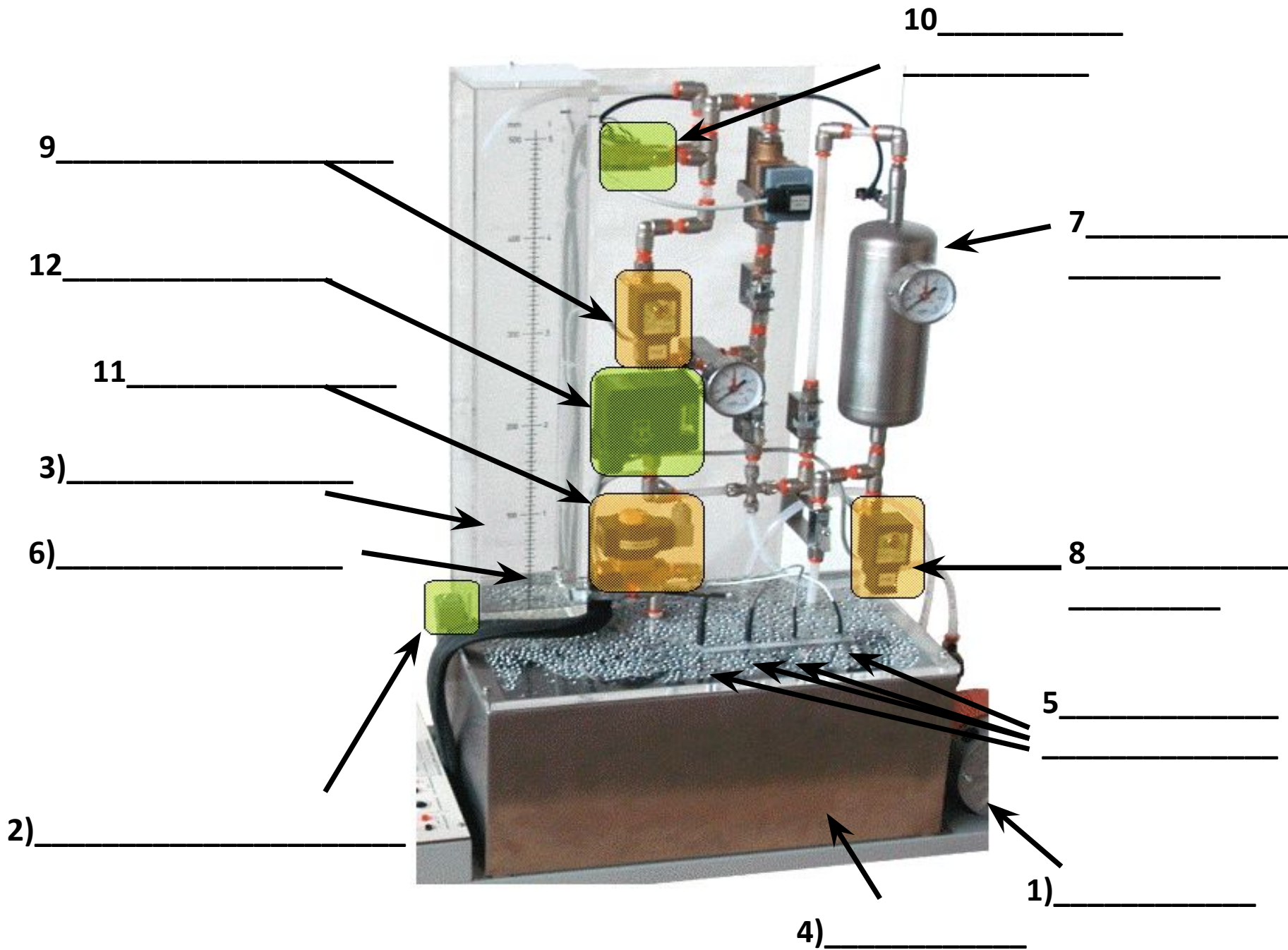

Valves

- Positive crankcase ventilation (PVC) is used to limit the pressure or flow rate
- PVD Power valve Double acting
- Solenoid Valve



1.5 Work Principle of External Unit.

- Liquid is kept in the metal vessel
- pump injects the liquid from vessel into the plexiglass tank through lines.
- Liquid Pressures, flow rates and level are measured when the pump works
- Heater warms up the liquid
- Temperatures are measured with thermal sensors on the metal vessel
- Valves help control the pressures and flow rates



2. Control Units

- PLC Trainer
- Industrial PID
- Control Card

2.1 PLC Trainer (PLC-5A/EV)

Учебная панель

- Has 16 digital inputs
- 14 digital outputs
- 4 Analog Inputs
- 1 Analog Output
- Connects to the touch screen

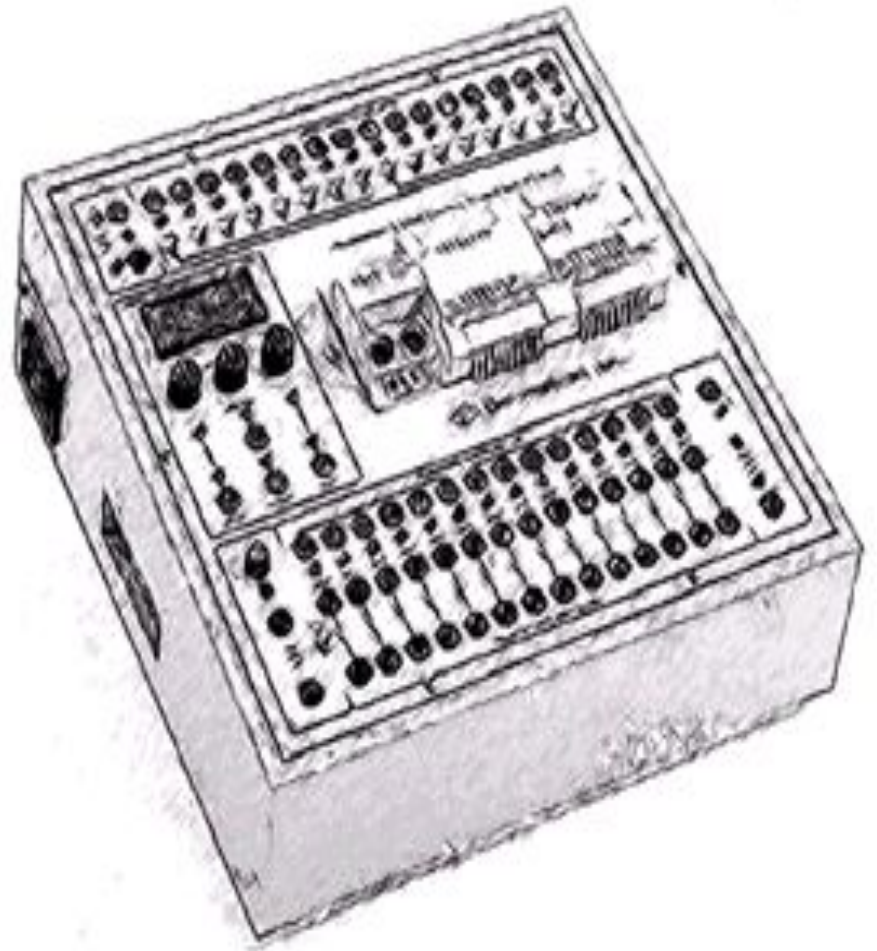

2.2 PID Controller

- Has inputs
- Outputs

Control Card (MFI-U/EV)

- Has 8 Digital Inputs;
- 8 Digital Outputs
- 16 Analog inputs
- 2 Analog Outputs

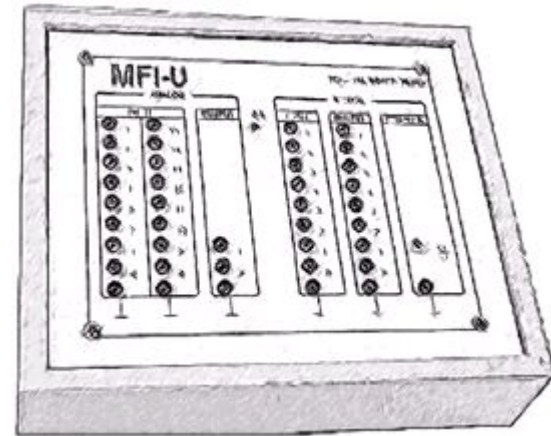

3 Control Techniques

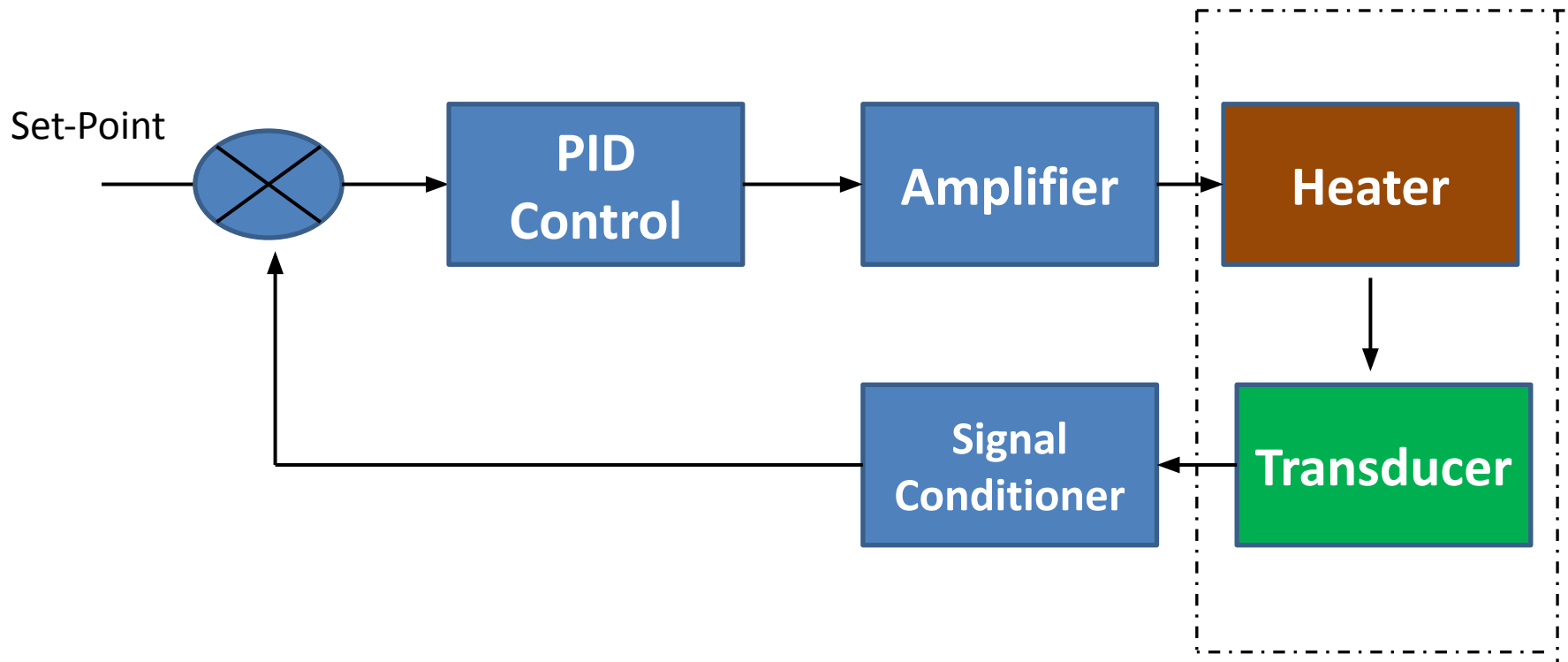

Question. Is it open loop or closed loop control?

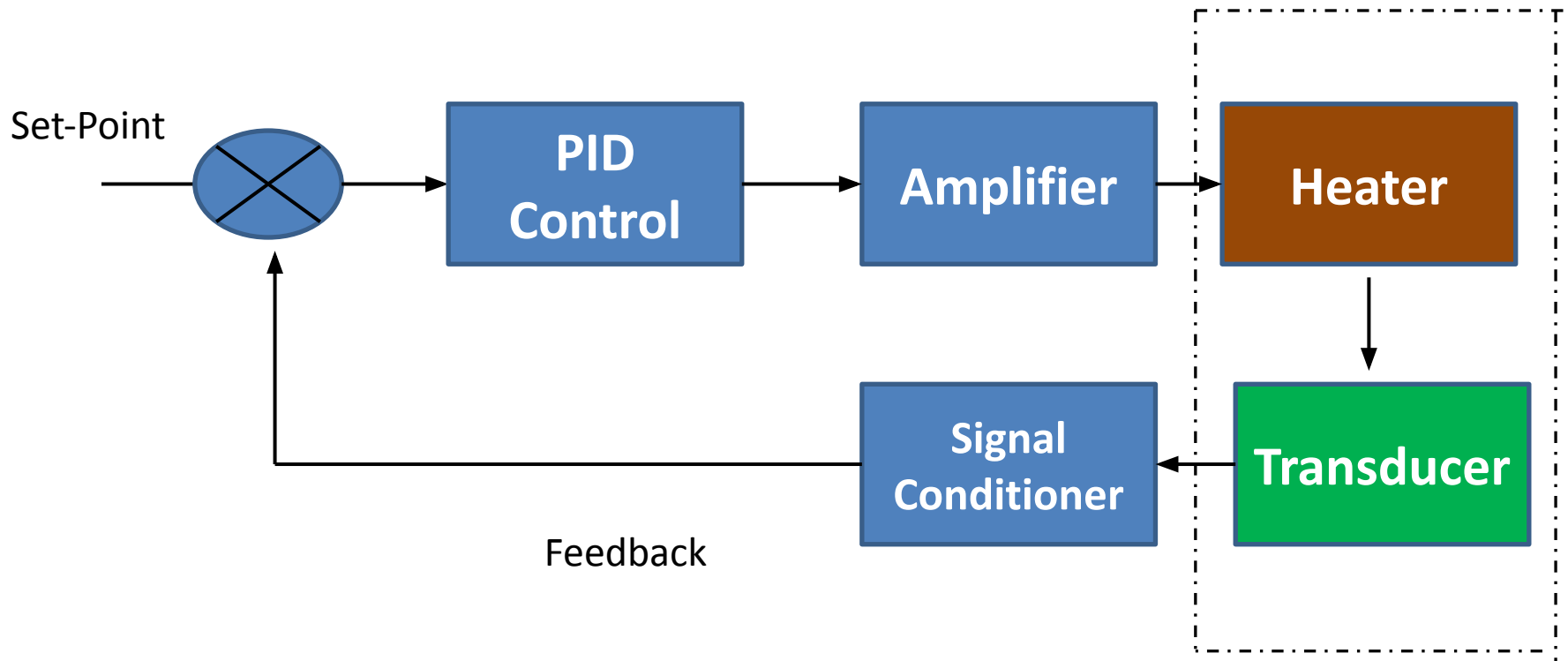

Answer: It is closed loop control because of PID Control and feedback

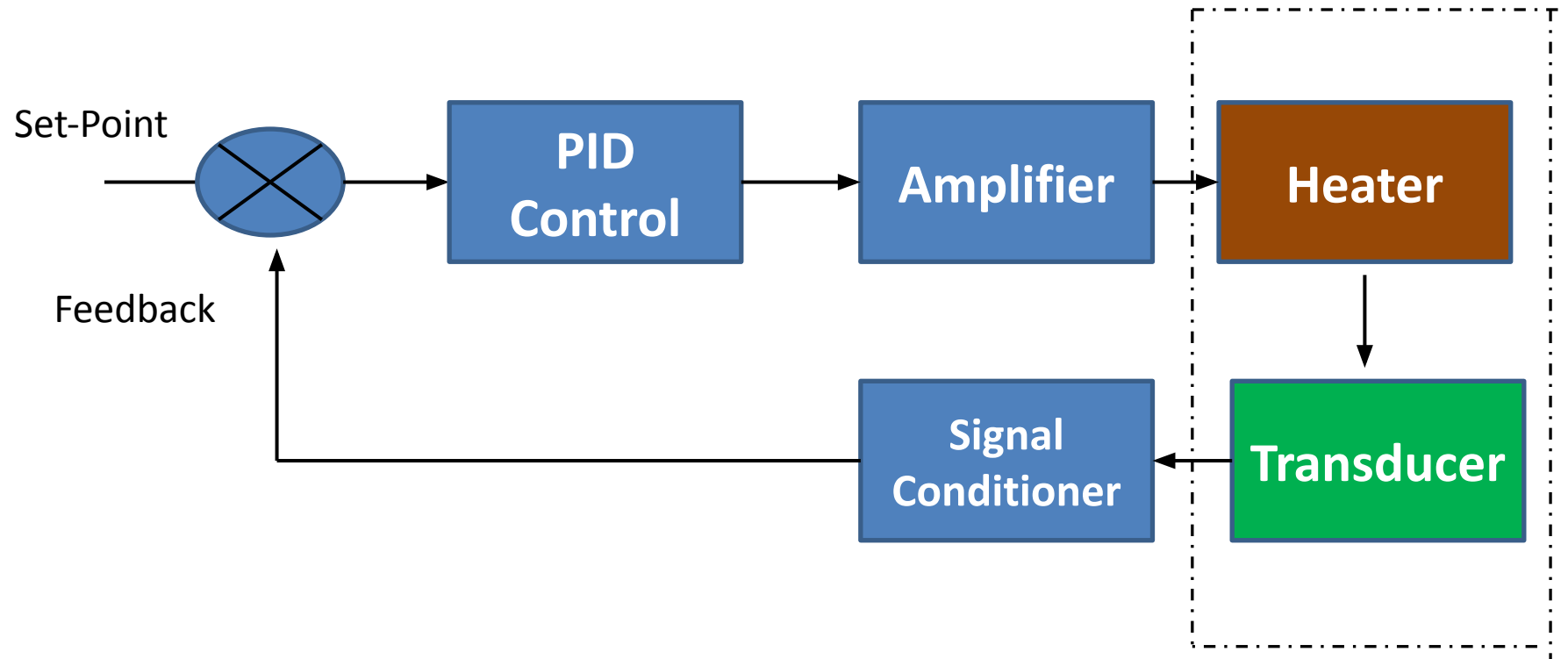

Open Loop Control

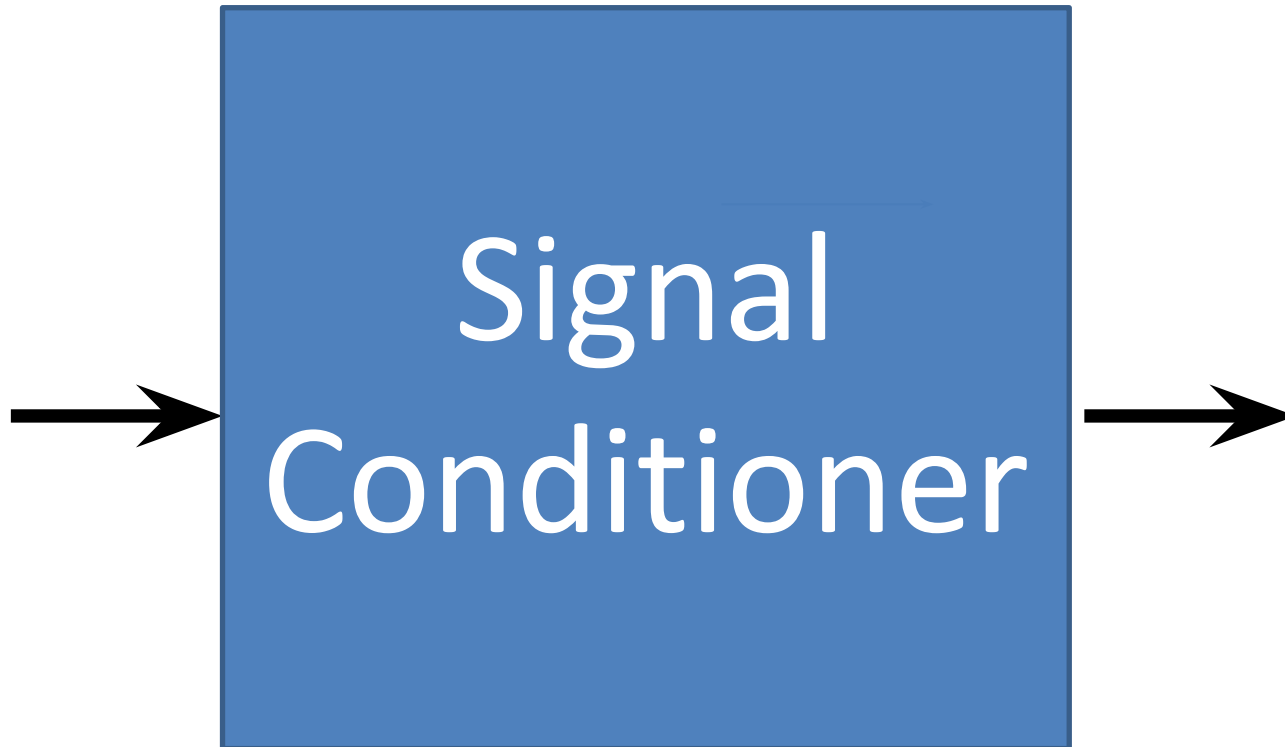

Question

- What are the transducers?

3 Transducers

- Converter from physical variable to the electrical variable.
Example: Pressure at 4 bars is converted to voltage at 7 Volts
- The transducer shows mostly the linear function
- Cannot be formed without the conditioner

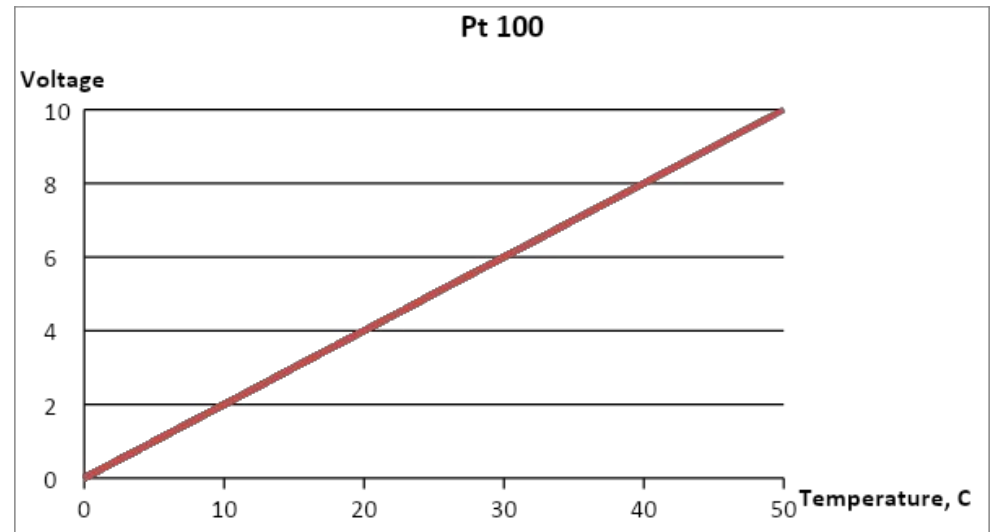
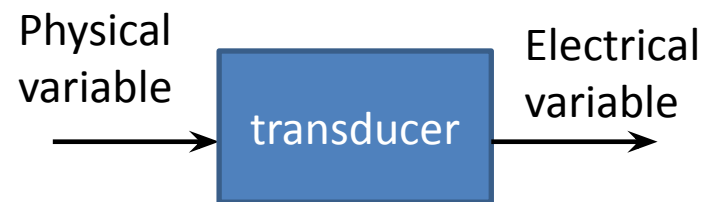

Question

- What is the Conditioner?

Conditioner

- Converter from undesirable electrical variable into suitable electrical variable
- Always comes with transducer



Temperature Control

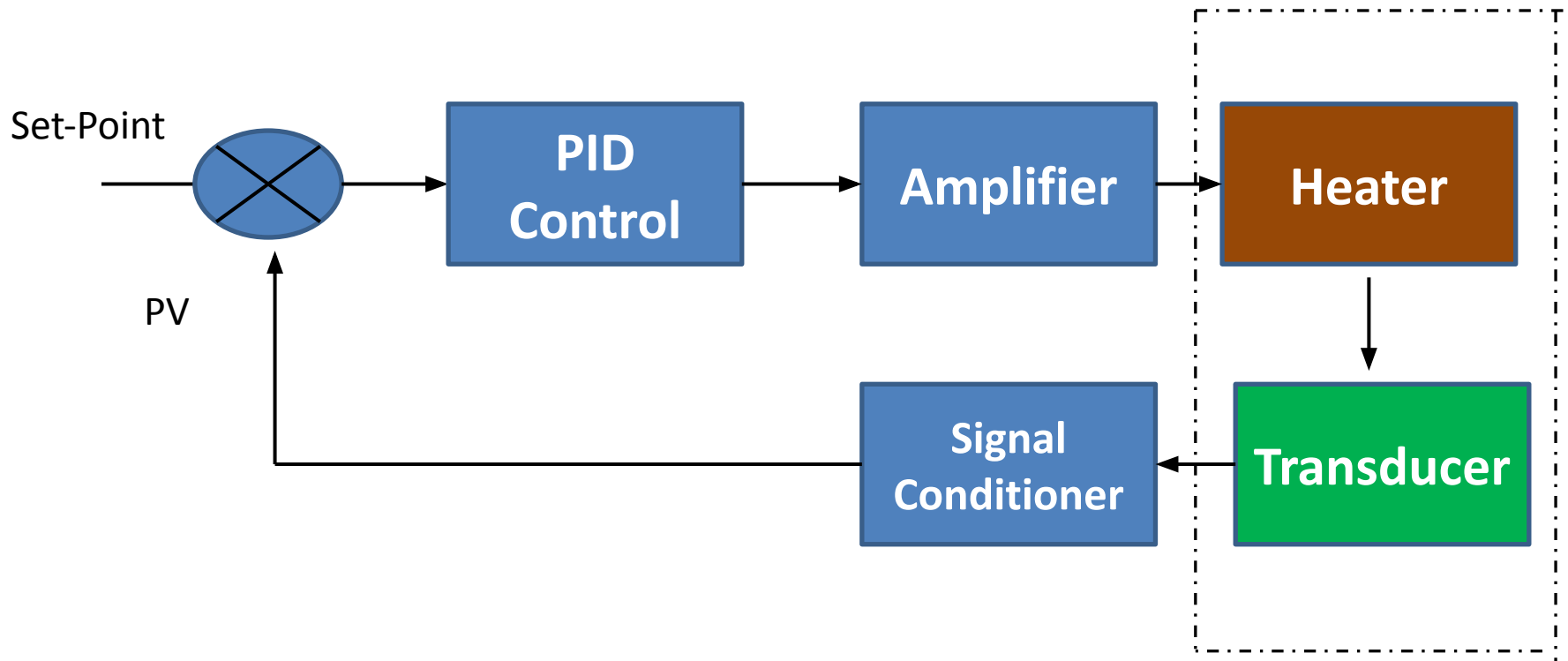

Pressure Control

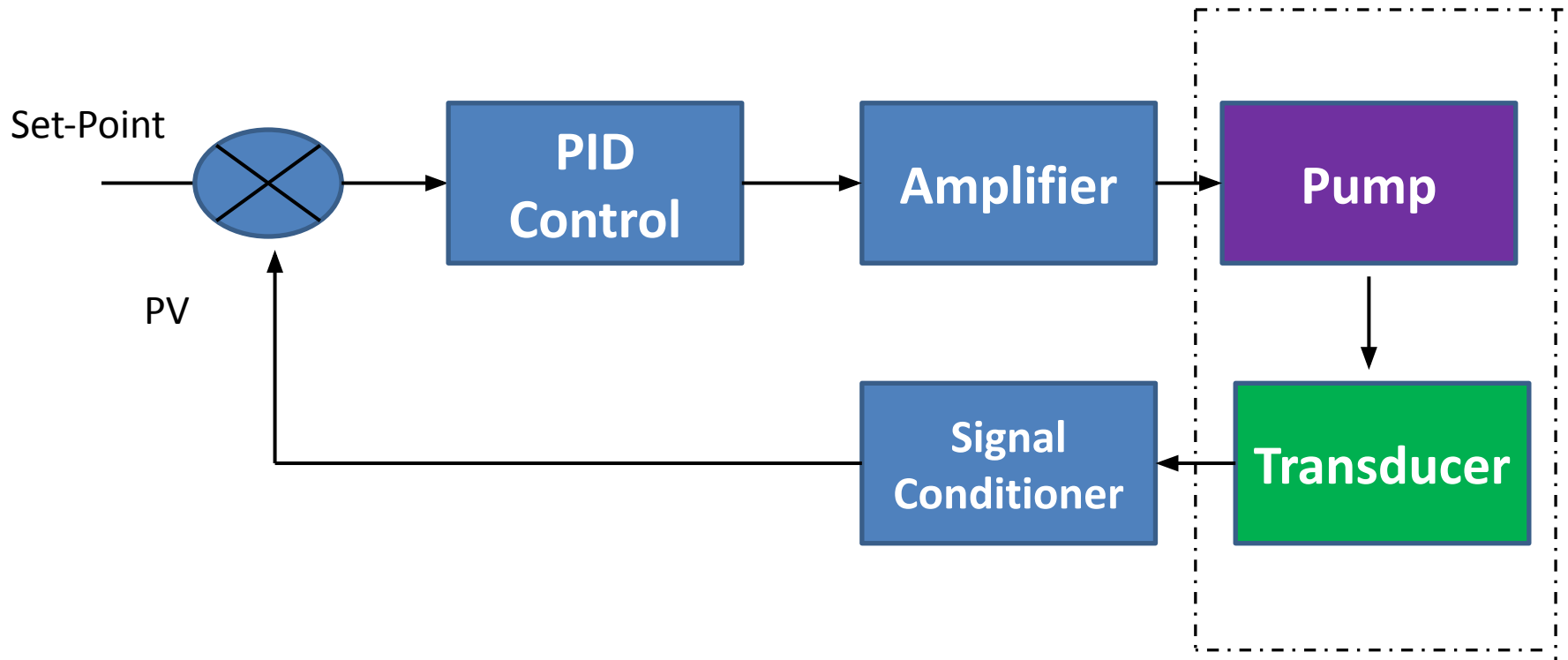

Summary

- Process Control System requires the control techniques, such as Amplifier, Conditioner, transducer and Heater or pump in the lab
- Without the Conditioner, transducer does not work
- Circulated control system makes closed loop control with PID technique, while open loop control misses PID control