

Name of discipline:

Transmission systems of access  
networks  
(TSAN)

Lecturer - Oreshkov Vasiliy Ivanovich

## Lecture 6

# HYBRID FIBER-COAXIAL NETWORK (HFC)

# **Traditional access by CATV and telephone networks**

Fig. 6.1 shows the general scheme of the traditional subscriber network. Main television station (Head End station ) receives satellite and terrestrial television channels as well as channels on the local cable television studio, performing their frequency multiplexing and forwards combined broadband spectrum signal through the main coaxial cable (trunk coax) - such stream of television broadcasts from the head end to the subscribers is called downstream.

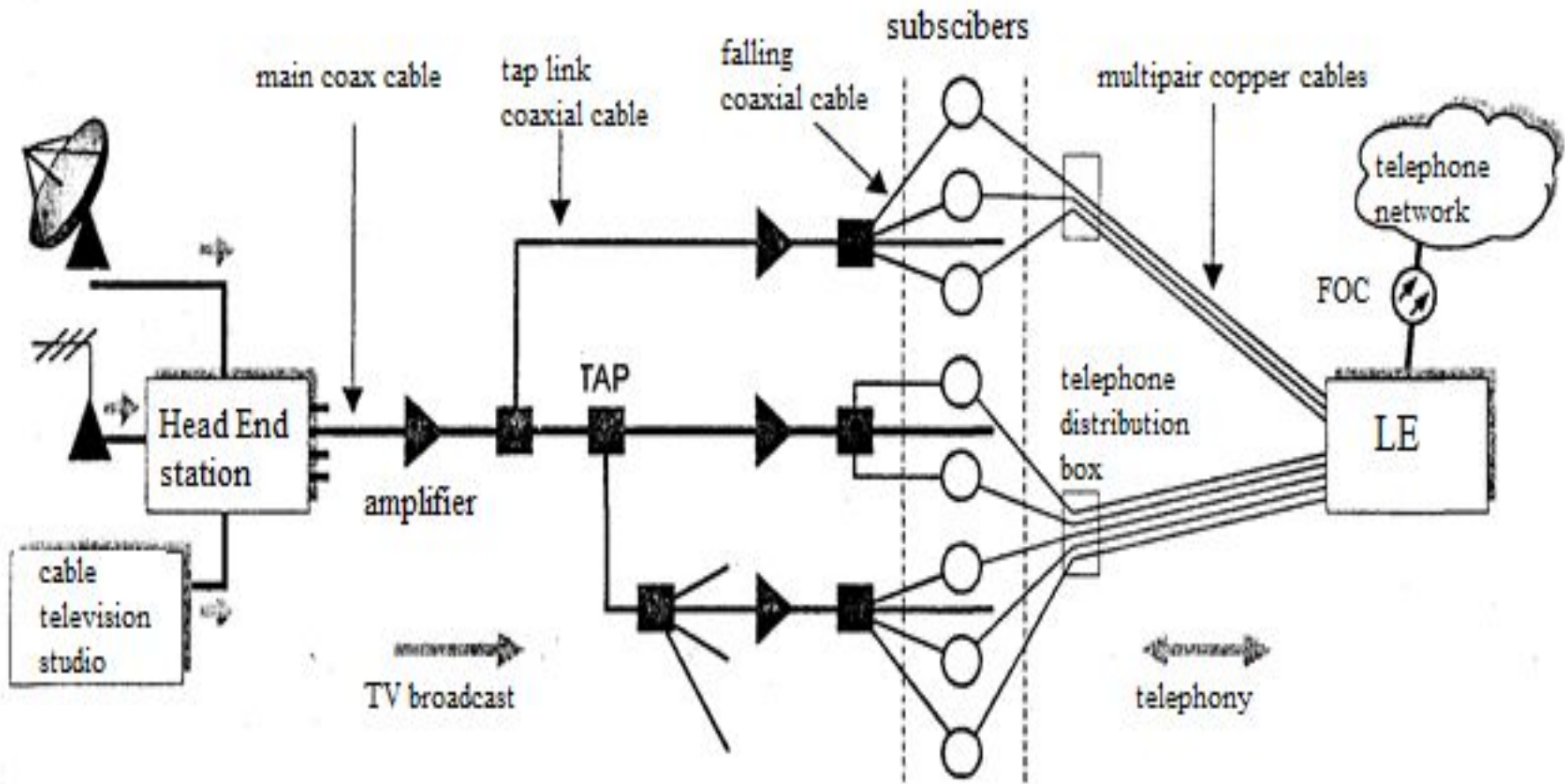

Fig. 6.1. Architecture of a traditional subscriber access network

From the main cable to the branch nodes - taps (tap) - can be separated by one or several branches of coaxial cable - coaxial branches (feeder coax) - in this case the tap can contain built-in distribution amplifier. Further branch cable tests, coming to the subscriber tap , from which the subscribers directly to the apartment followed by falling coaxial cables (drop coax). Multi pair copper telephone cables are run from the regional telephone exchanges to street cabinets installed in residential areas , in each of which there is a cross connection of twisted pair cable from the exchange and cables from subscribers.

Thus, firstly, the network subscribers are provided for receiving television channels.

Secondly, subscribers are provided with a telephone service that is unlike television is bidirectional. While traditional subscriber network will be replaced by new networks such as HFC, they still provide a very large installed base. The maximum distance from the main node to the very far end is 10 ... 15 km. The maximum number of amplifiers in cascade is 35, the maximum number of subscribers that can be connected to the trunk coaxial cable, - 12500.

# HFC network

The hybrid fiber-coaxial network HFC (hybrid fiber/coax) is based on the coaxial and fiber optic cable systems, and uses the best features of each of them (see Figure 6.2). HFC network is less expensive compared to the network where the fiber goes directly to every home (the concept of FTTH) - only medium and large businesses can afford to bring fiber directly to the office. At the same time the HFC network provides a much more services than traditional purely coaxial TV network. These services include: video service, telephony, interactive services, data services, etc.

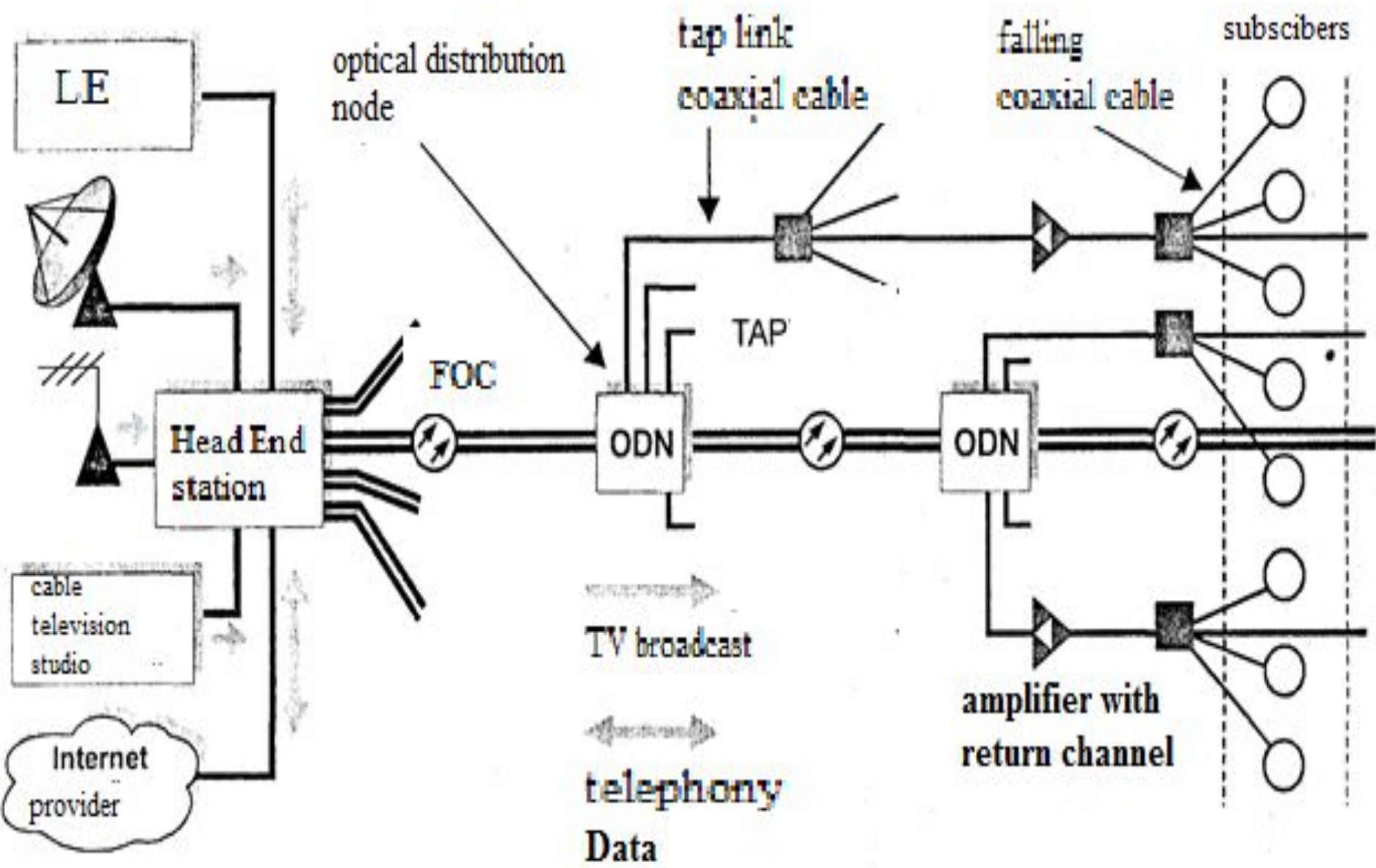

Fig. 6.2. The architecture of hybrid fiber-coaxial network user access (HFC)



Appointment of fiber in HFC networks much the same as in telephone networks which, based on FOC built more extended trunk lines between local and city telephone exchange. In HFC networks the maximum length of the FOC can be up to 80 km . In a typical configuration, rack-mount optical laser transmitters (mostly on the basis of DFB lasers ) in the central office or head end transform broadband radio frequency signals into equivalent analog optical signals, which are followed by the FOC to the corresponding optical distribution nodes (ODN).

The optical signal coming in ODN, again converted into an electrical\followed by coaxial branches of the subscriber to the subscriber end couplers maximum number of amplifiers in the coaxial branches varies from 4 to 10 depending on the architecture of the manufacturer. The maximum number of users per one main POC from 500 to 3000.

The fundamental difference between these networks from traditional subscriber coaxial cable networks (along with the fact that the added fiber-optic tract) is a bi-directional traffic, that is, there is flow from the subscriber to the main node, it is upstream.

# **Details of the HFC network**

HFC network involves the installation of equipment at a mutually agreed main node (HC, main node controller, main controller), at the optical distribution node (ODN) and at the subscriber side (ISU, integrated service unit, a subscriber unit). At present the development of a standard IEEE 802.14, which determines the methods of access to cable TV networks - MAC level (especially with respect to network HFC), as well as regulating the specification of the physical layer, an alarm system and communication protocols with local and global data networks.

Many companies specializing in the production of telecommunications network equipment supplying a large inventory of HFC equipment. The most advanced solutions provide companies: ADC Telecommunications, Motorola, Nortel, NTT, Scientific Atlanta, Warner Cable. First, they provide a versatile transport solutions, tightly tied to the plan worked out by the frequency of upward and downward flows in accordance with the standards of broadcast television networks. Second, is the possibility to build the network, in particular the use of the upper part of the spectrum band up to 1 GHz .

# **The physical layer specifications of the 802.14 standard**

802.14 physical layer specifications support asymmetric bidirectional transmission of signals on network HFC. HFC network allows for the downstream connection type "point -to-multipoint" topology with a generalized access branched tree , and for the upstream type compounds "multipoint -to-point" - with the topology of the bus access .

The transfer controller is formed downstream of the National Assembly and is broadcast, i.e. mandatory to receive all subscriber devices.

Upstream transmission devices formed on the subscriber side of the ISU and reach the National Assembly by the total coaxial distributed environment.

One of the important problems which is solved in the framework of the standard 802.14 - MAC protocol is to support various types of traffic. Unlike many other network standards, the HFC network to support three main services:

- Constant bit rate (CBR);
- Variable bit rate (VBR);
- Available bit rate (ABR).

These services have several different attributes, in particular the allowable delay "explosive" nature of traffic. Some applications are asymmetric in nature, such as TV broadcasts. Other applications, on the contrary, should strictly be symmetrical: voice, video telephony. All of these requirements were taken into account when creating the most optimal protocol.

# Frequency distribution of streams

General diagram of the frequency distribution of streams is shown in Fig. 6.3. As we can see, initially supposed to use the frequency range from 5 to 862 MHz, and in the long term and the area from 862 MHz up to 1 GHz. Under the traditional analog TV frequencies are removed from the 50 to 550 MHz. In Ukraine adopted a television frequency grid with the release of the band is 8 MHz on every TV channel.



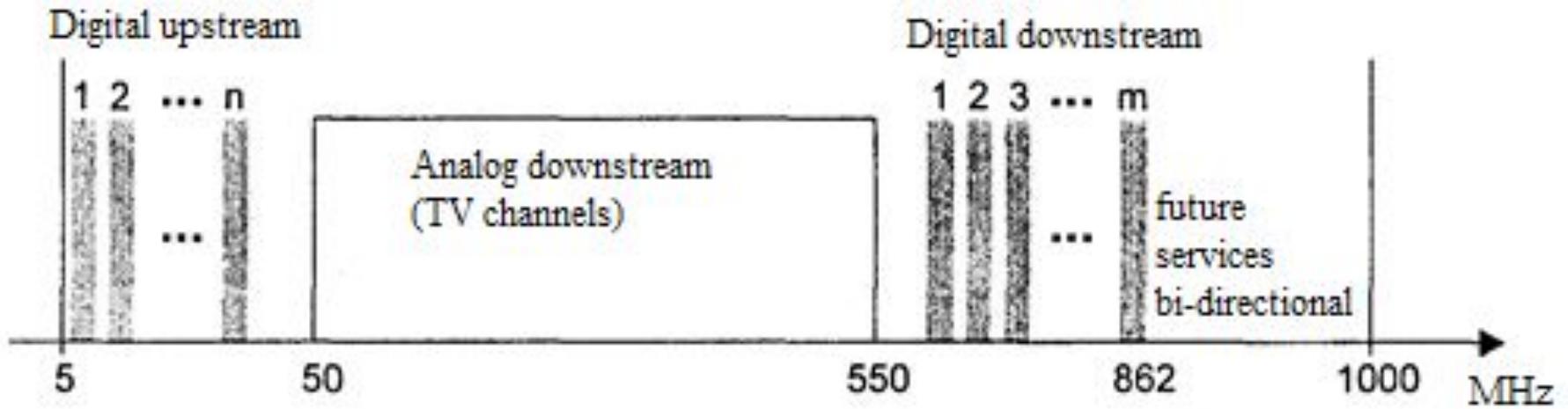

Fig. 6.3. The frequency distribution of flows in the coaxial branches

Range from 550 to 862 MHz can be used for transmission of digital broadcast television programs transmitted in format MPEG-2/MPEG-3, to arrange a conventional video telephony, as well as closed channels broadcast " video on demand " VOD (video on demand) and interactive video .

# The upstreams distribution

The carrier frequency  $f_c$  must satisfy the condition:

$$\left( f_{\min} + (1 + \alpha) \cdot \frac{R_s}{2} \right) < (f_c - n \cdot (40 \text{ кГц})) < \left( f_{\max} - (1 + \alpha) \cdot \frac{R_s}{2} \right)$$

Where roll-off factor  $\alpha = 0.25$ ,  $n$  - integer,  $R_s$  - symbol rate at the carrier frequency, and  $f_{\min}$  and  $f_{\max}$  are determined from the table. 6.1.

Tab. 6.1. Upstream frequency plan

Region	$f_{\min}$ , MHz	$f_{\max}$ , MHz
North America	5	42
Europe	5	65
Japan	5	55

In practice the choice of the frequency allocation of channels depends on factors (such as to avoid overlaps in access, input and power loss) and not regulated by standard 802.14.

## **The downstream distribution**

A window that allowed placement of downstream digital streams is different for the three regions (Table 6.2). The large size of the window does not mean that you can freely use any portion of the spectrum. In that spectral range analog television channels is placed.

The analog television channels frequency location is strictly defined telecommunications laws of the each country.

Tab. 6.2. Downstream frequency plan

Region	$f_{\min}$ , MHz	$f_{\max}$ , MHz
North America	88	860
Europe	110	862
Japan	90	770

# Physical features of upstream and downstream

Using modulation schemes based on quadrature amplitude modulation QAM-64 and QAM-256 allows to transmit downstream digital channels at the rate of 30-40 Mbit/s , which is possible due to its low noise levels. Reverse digital stream uses less prone to interference modulation QAM- 16 and/or the quadrature - phase modulation QPSK, since being placed in the low-frequency part of the spectrum is strongly influenced by noise. QPSK can send streams of up to 2 ... 10 Mbit/s.

Why does upstream locate in the lower part of the spectrum (5 ... 45 MHz )? First of all, this is due to the asymmetry of downstream and upstream. To increase the total (total in both directions) of bandwidth, lower - largest stream should be placed in the region of the spectrum with greater redundancy code.

As a result, placing the lower part of the upstream of the spectrum can be used in coaxial branches not only bidirectional amplifiers and amplifier but with a reverse channel, which amplify the signal forward and reverse passes it unchanged.

Since the attenuation in the coaxial cable is less significant in the low range, it allows the signal to reach the receiver is connected to the ODN without intermediate amplification while maintaining the required power at reception.

Three types of physical layer PHY for downdrafts A, B and C are supported by standard 802.14 (Table 6.3). Type C is identical to the type A for the major exception that the type A uses an 8 MHz channel (PAL / SECAM), and type C - 6 MHz (NTSC). The main difference between types A and C methods consists in coding.

Tab. 6.3. Main parameters of the physical layer for the three types down streams A, B, C

Parameters	A (Europe)	B (North America)	C (Japan)
Nominal bandwidth, MHz	8	6	6
Coding method for error correcting	block RS-coding (RS-Reed-Solomon)	Truncated coding with external RS-code	block RS-coding
Modulation	QAM-64, QAM-256		
Carrier frequency $f_c$ , кГц	$(n-250) \pm 30$	$(n-250) \pm 30$	$(n-250) \pm 30$
Roll-off factor, $\alpha$	0,15	0,18; 0,12	0,13
Bitrate $R_s$ , Msymbols/s	6,0...6,95	5,057...5,064 5,19...5,36	5,0...5,31



# Conclusions

We formulate the basic principles on which the HFC network , and trends in their development :

- Broadband asymmetric streams: the stream from the main node to the subscriber is much higher than the reverse. Allowed a gradual migration to a more symmetric traffic volume when upstream increases, in particular the usage of high-frequency part of the spectrum up to 1 GHz for bi-directional service.

- Hybrid system: fiber -optic cable and coaxial cable plus twisted pair. Laid gradual transition to FTTH infrastructure with the development of technological and economic base.

- Hybrid transmission of information: analog and digital. Allowed a gradual transition to digital transmission only.

- The distributed architecture of the network: the network devices installed on the main node to the distribution hub for the subscriber side. Perhaps the gradual alignment of intelligence between network elements .

- Integrated information flows cover almost all of its types: voice, video, data in different formats. IEEE 802.14 standard provides for a transition to a universal transport of information technology-based ATM, Ethernet.

- Intelligent centralized network management, monitoring, testing, and distributed access to management. It is allowed the redistribution of information flows with the differentiation of streams for the organization of services and control flow elements of the network.
- Durability: "nested" structure of the redundant cable network and basic equipment. Auto rebuild in the event of an accident, distributed complex power system.