

HANA



4 cylinder only
Mini size (110*110*35)







4, 6, 8 cylinder
size (152*145*35)

Note : PC Soft ware and communication cable are different

E.C.U Indicator (One Touch Switch)

Auto / Manual (Gasoline only) mode switch

Display (Auto/Gasoline)	Auto mode (gasoline->gas)			gasoline only mode	
	Red/Green lamp On	Gas Green lamp flickers	Gas Red lamp On	Gasoline Red lamp On	
					
Operating Status	gasoline	converting to gas	gas	gasoline only	

GAS volume

Display (GAS Mode)	Red lamp on	1 green lamp on	2 green lamp on	3 green lamp on	4 green lamp on
					
LPG	Empty(below 15%)	Low (15~20%)	Middle(20~40%)	High(40~70%)	Full(over 70%)
CNG	Empty(below 7MPa)	Low (7~10MPa)	Middle(10~13MPa)	High(13~17MPa)	Full(over 17MPa)

LPG Injection system (4cyl. Only) – H2001

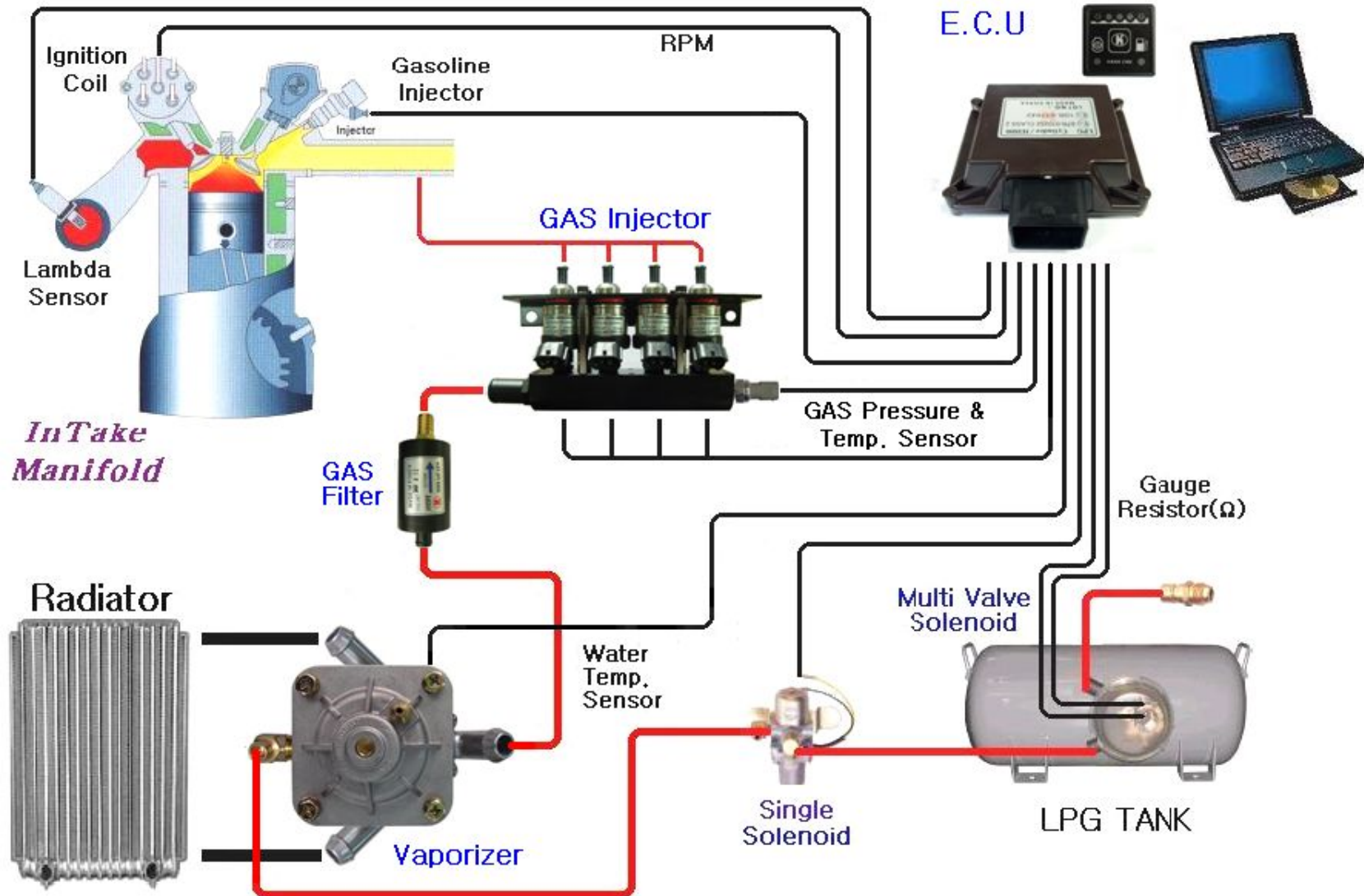

Products for LPG Injection System



E.C.U & Indicator



Injector



Vaporizer



GAS Filter



Single sol. Valve



Filling Unit



Flare Nut



Water & GAS Hose



Hose Bend



Pressure & Temp. s/s



Copper Pipe



Program Wire Set

CNG Injection system (4cyl. Only) – H2001

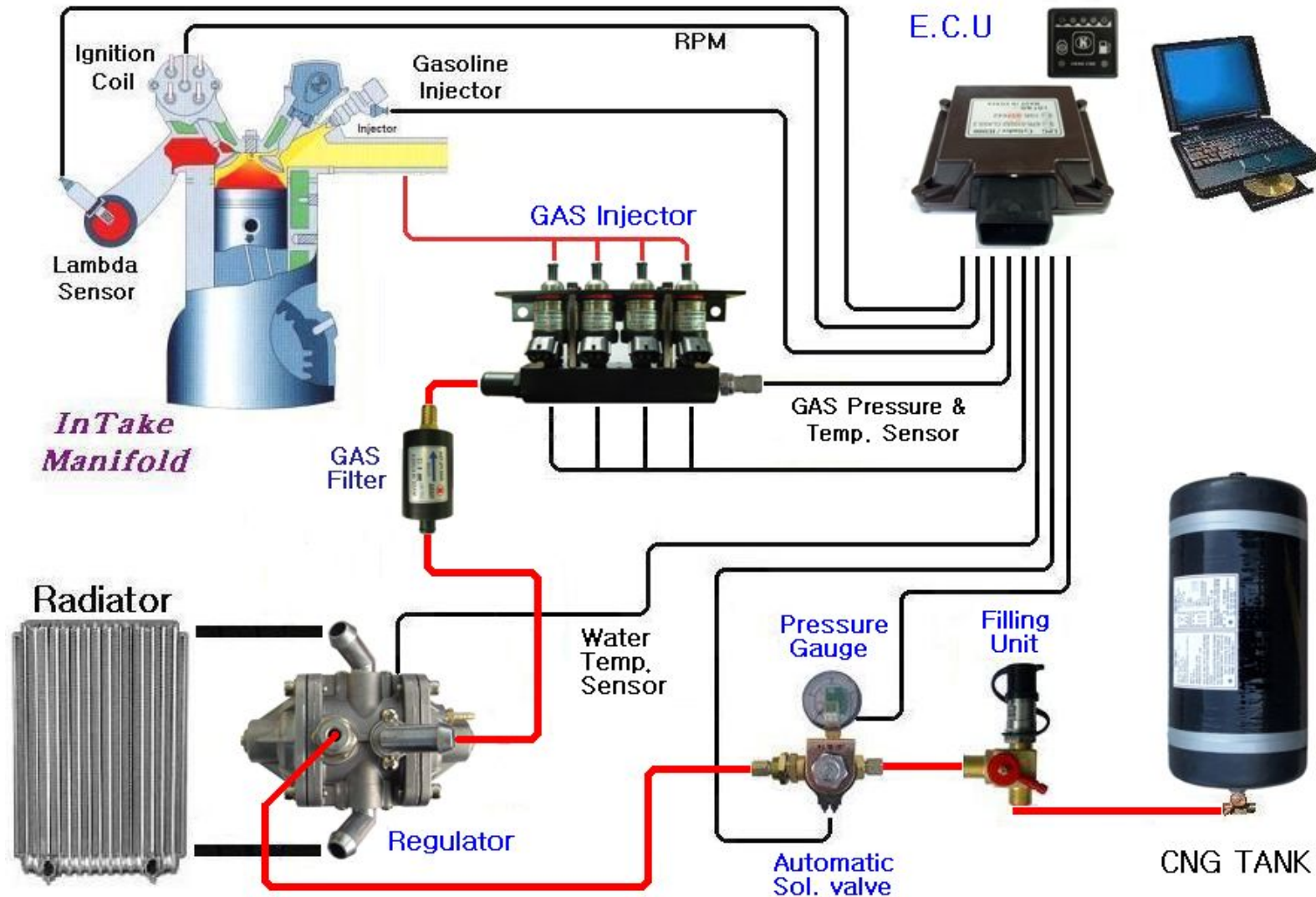

Products for CNG Injection System



E.C.U & Indicator



Injector



Regulator



GAS Filter



Automatic sol. Valve



Filling Unit



Pressure Gauge



Water & GAS Hose



Hose Bend



Pressure & Temp S/S



Steel Pipe



Program Wire Set

LPG Injection system (4cyl. Only) – H2002

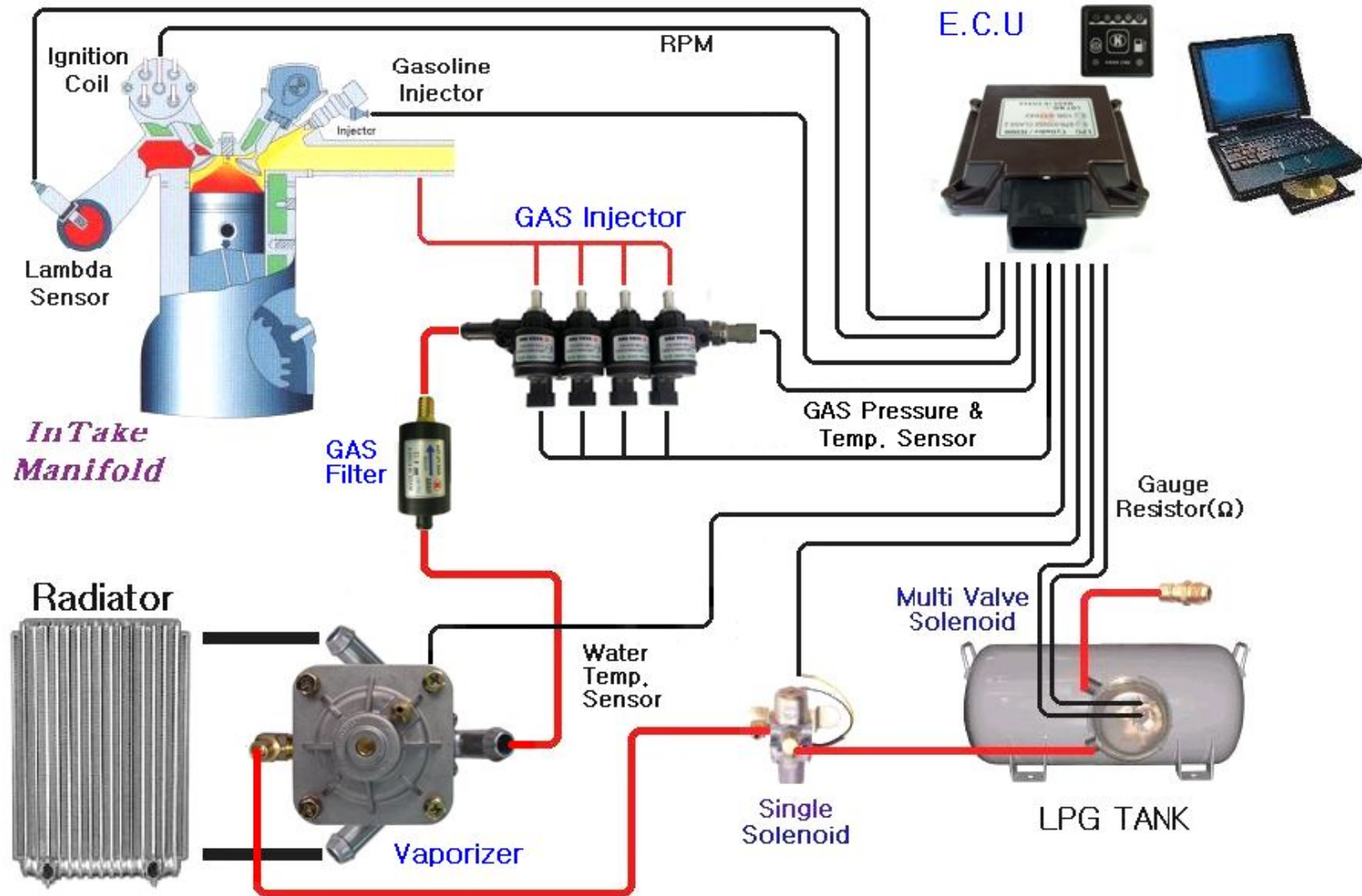

CNG Injection system (4cyl. Only) – H2002

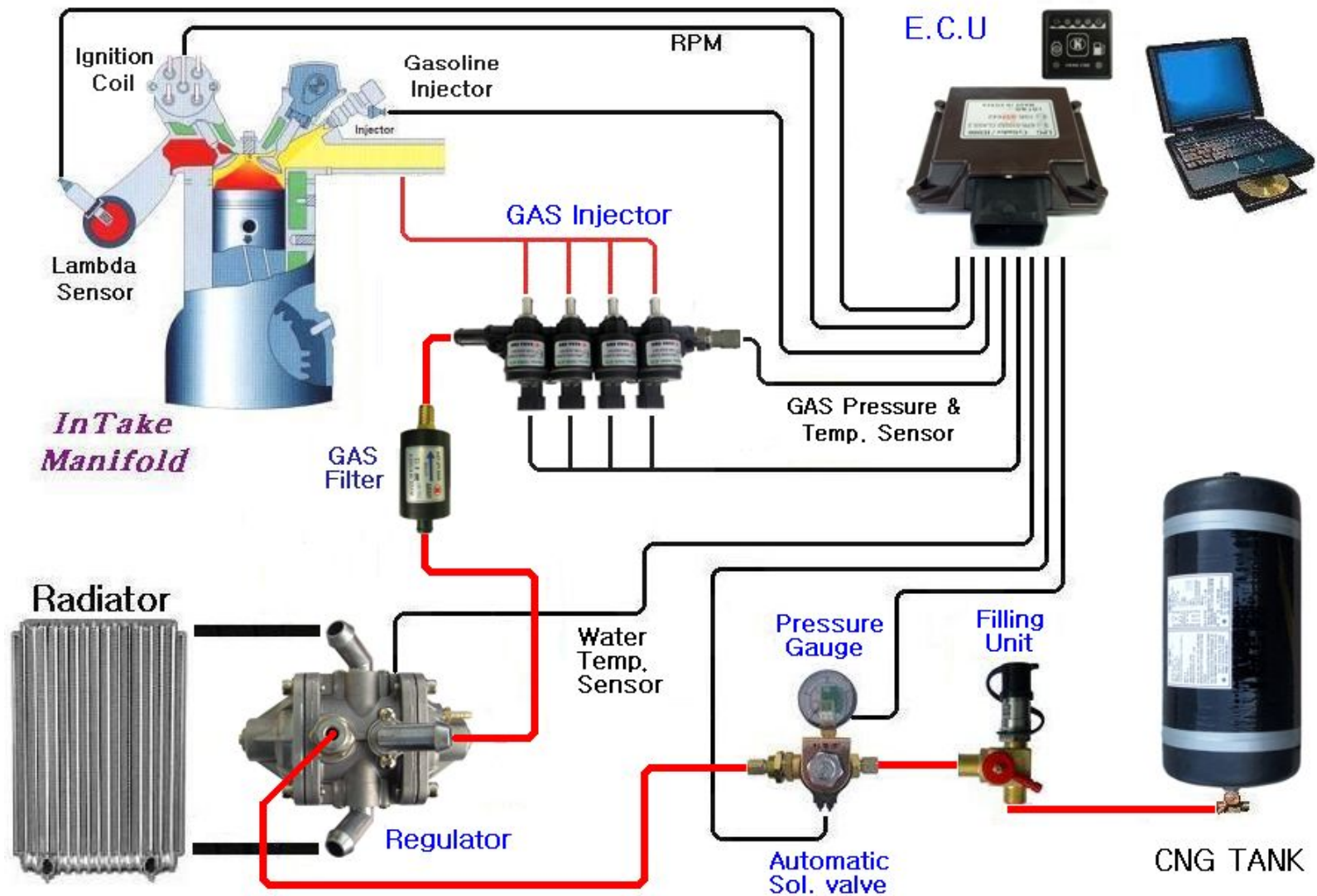

LPG Injection system (6 cyl.)

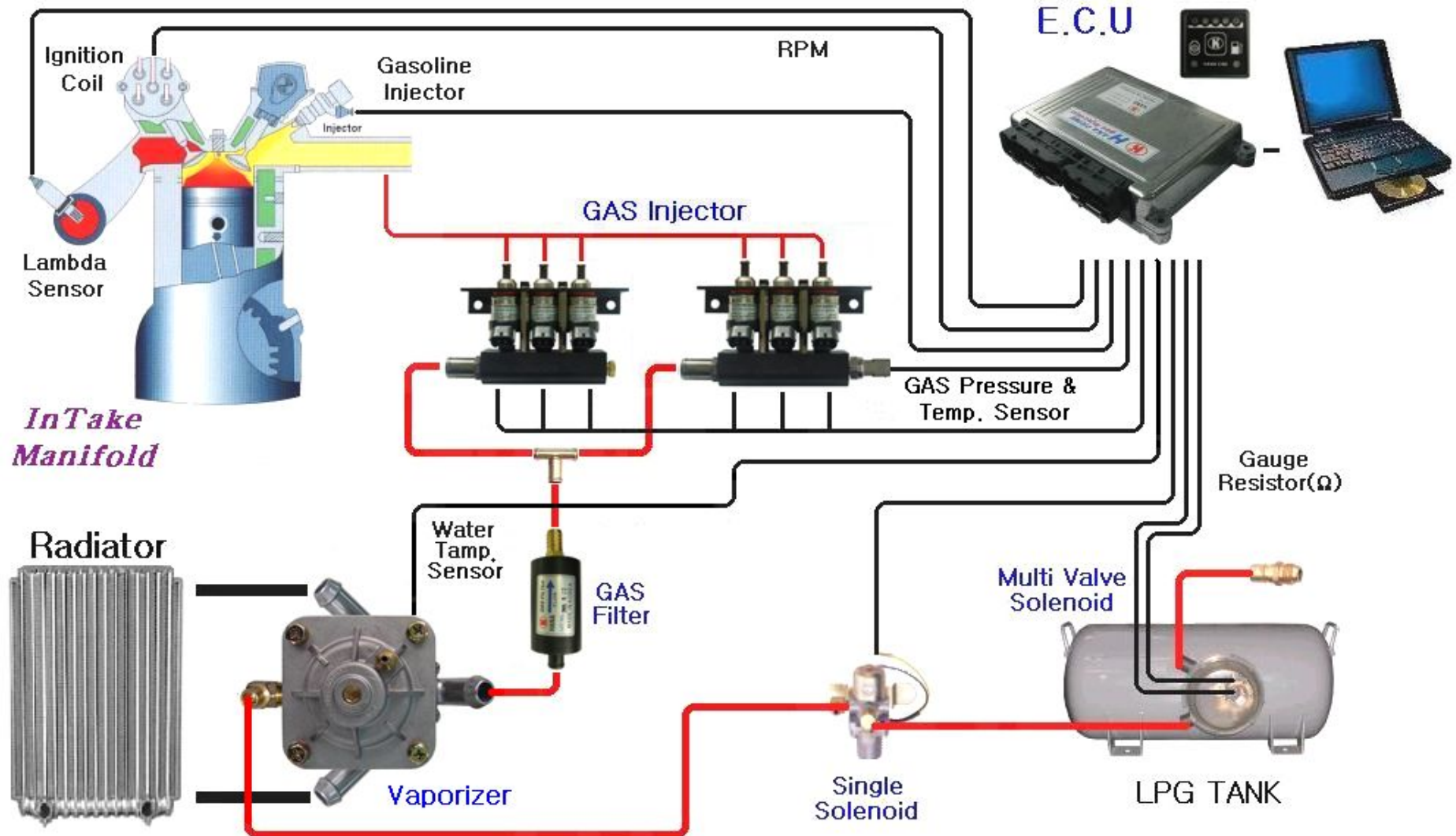

LPG Injection system (8 cyl.)

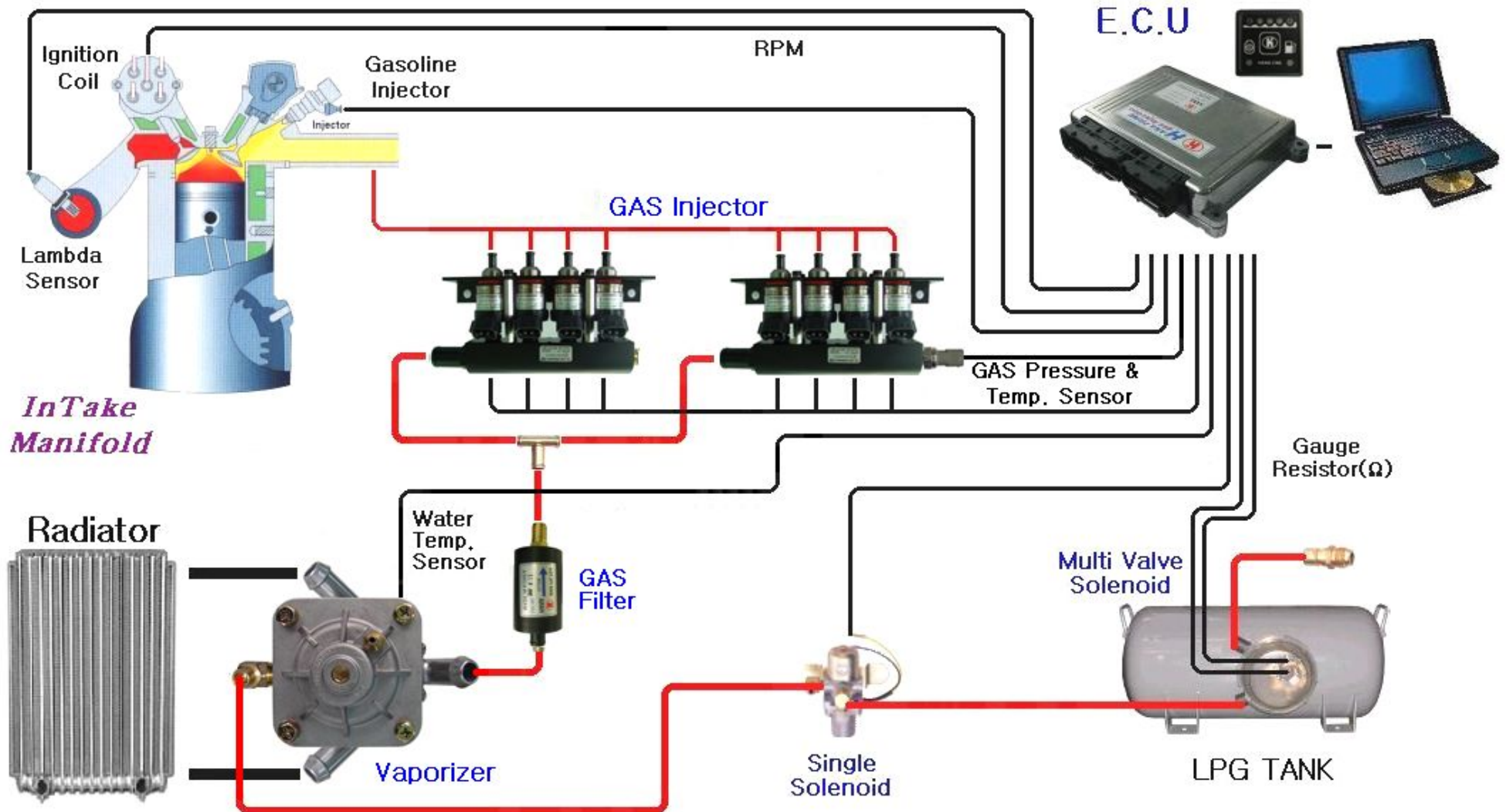

CNG Injection system (6 cyl.)

