



Dosing to Perfection

Maintenance Seminar

Introduction介绍

Topics Part 1:

- **Erection and Installation**
- **Breakdown Maintenance**
- **Preventive Maintenance**
- **Condition Based Maintenance**
- **Wear and Repair**

- **Explanation on real cases**

TOPICS Part 2:

- Access to Feeder Controller CSC
- Troubleshooting

TOPICS Part 3:

- Spare Part Management
- Spare Part Packages

Summery – Conclusion - Questions – Discussion

end of day 1

Day 2 - Practical Training in the field

Our support does not end at the sale of the equipment

but

it's the beginning of a long-term partnership

with our common target

maximum equipment efficiency at low operating costs

high customer satisfaction due to reliable feeder equipment

adequate reaction-time and fair prices

□ **Erection and Installation**

Typical Installations

direct removing

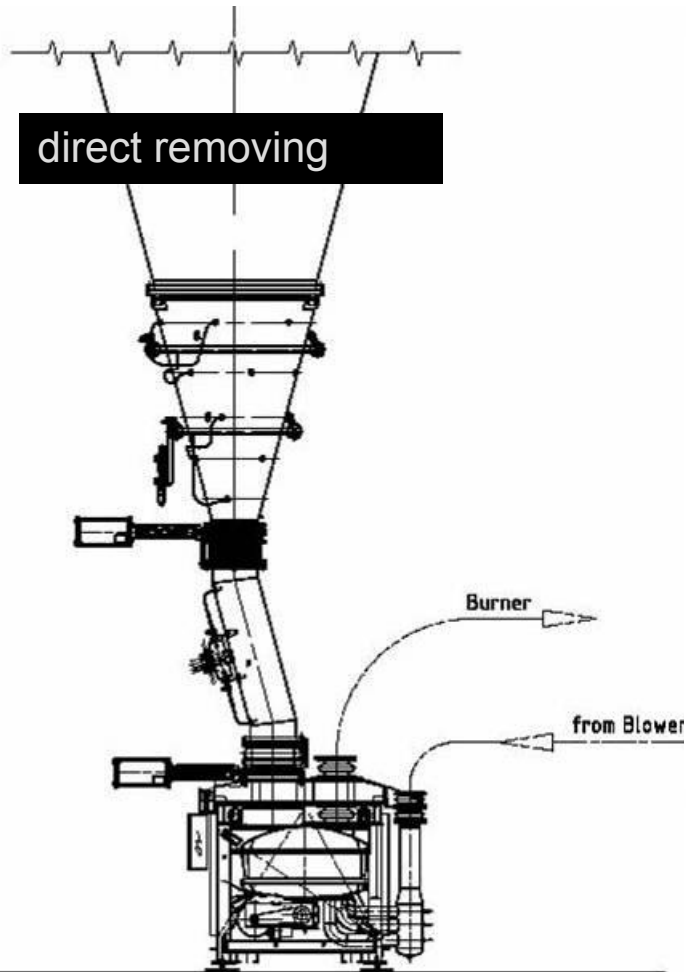

activator – prehopper - feeder



Mounting Instructions

MOUNTING INSTRUCTIONS Rotor Weighfeeder DRW 4.10/4.12/4.14



TRM / 29.07.2005

550.096.60.04-MA-a-GB

ROTOR WEIGHFEEDER DRW 4.10/4.12/4.14

Contents.....	Page
1 Transport	2
2 Assembly of the rotor weighfeeder	3
2.1 Setting up the DRW	4
2.1.1 DRW without control measuring device	4
2.1.2 DRW with control measuring device	4
2.1.3 Securing the base plates.....	5
2.2 Swiveling the shut-off gate	5
2.3 Connection of pneumatic cylinder to solenoid valve.....	5
2.4 Connection of compensators.....	6
2.5 Connecting the blow pipe compensation.....	7
2.6 Installation tolerances for compensators.....	8
3 Installing the dosing station for coal dust.....	9
3.1 System set-up.....	9
3.2 Notes	10
3.3 Installing the prehopper.....	10
3.4 Installing the silo cone, SGA, shut-off gate and rotary valve	10
3.5 Installing the intermediate pipe with compensators.....	10
4 Electrical connections	11
5 Compressed air connection.....	12
6 Disassembly	12
7 Index History.....	12

MOUNTING INSTRUCTIONS Rotor Weighfeeder DRW 4.10/4.12/4.14



TRM / 29.07.2005

550.096.60.04-MA-a-GB

2 Assembly of the rotor weighfeeder

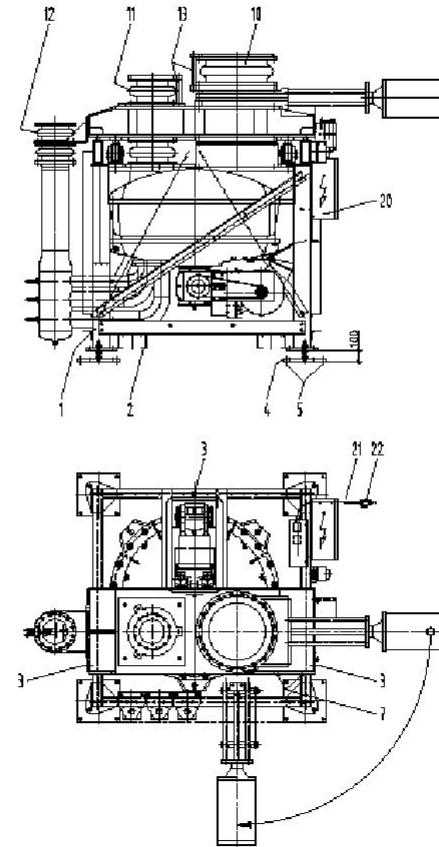

Figure 2: Rotor weighfeeder DRW

typical installation nonconformity



**allowed tolerances must be respected
refer to Mounting Instr. 550.096.60.04 MA chapter 2.6**

typical installation nonconformity

MOUNTING INSTRUCTIONS		
Rotor Weighfeeder DRW-4.10/4.12/4.14		
TRM-/29.07.2005	550.096.60.04-MA-a-GB	

2.6 → Installation tolerances for compensators

Location deviations for the downpipe compensator (10); → Fig. 2

Tolerances	Rotor weighfeeder	Compensator	Dimension
Axial installation length tolerance	DRW-4.10	DN-400-PN-10	178 \pm 5 mm
	DRW-4.12	DN-500-PN-10	242 \pm 5 mm
	DRW-4.14	DN-600-PN-10	250 \pm 5 mm

Lateral and angular tolerances can be ignored when a downpipe is used.

Location deviations for the blow-out pipe compensator (11); → Fig. 2

Tolerances	Rotor weighfeeder	Compensator	Dimension
Axial installation length tolerance	DRW-4.10	DN-150-PN16	150 +5 -0 mm
		DN-200-PN16	
	DRW-4.12	DN-250-PN-16	

nonconformance feeding pipe installation

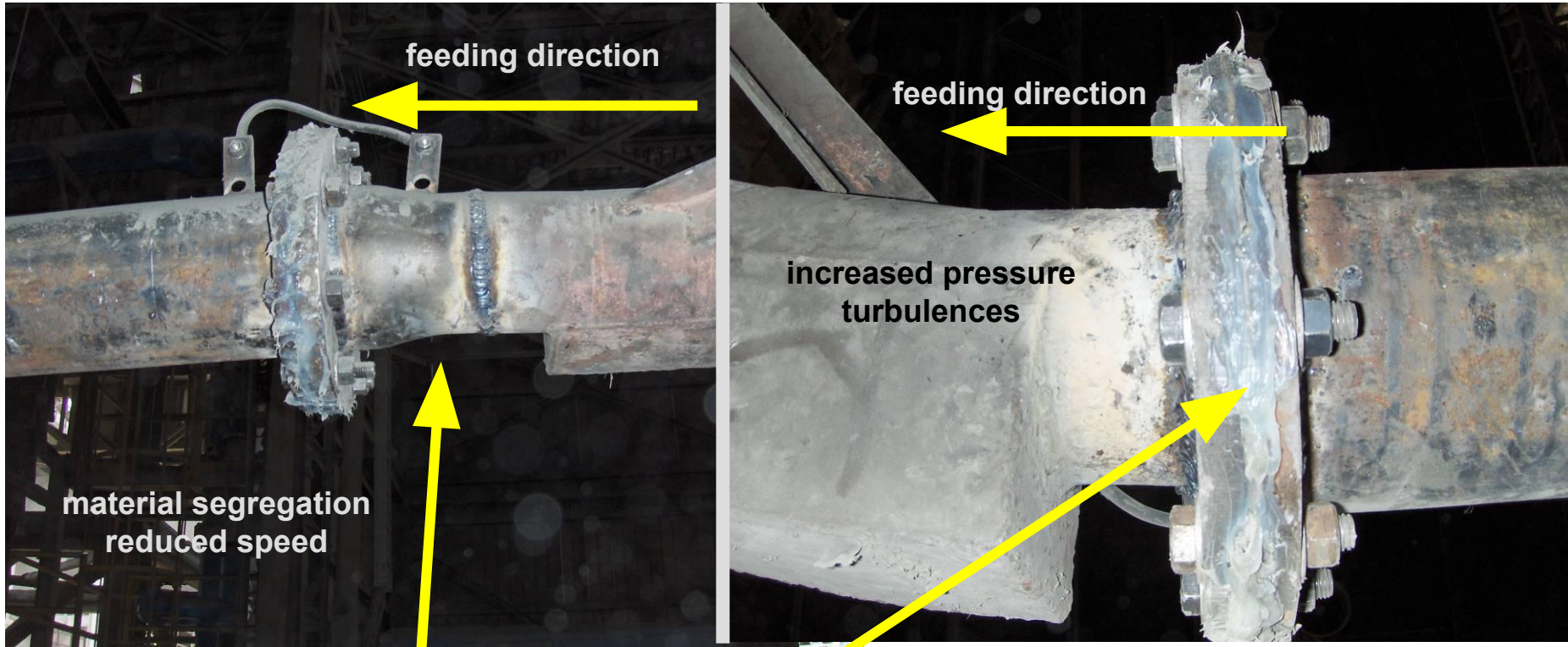

**enlargement or reduction of the feeding pipe
influences speed and pressure
causes turbulences, segregation and fluctuations**

nonconformance feeding pipe

3 x 90° bends
without acceleration
distance
between the bends
directly after the feeder



preferential routing only vertical and horizontal

Installation nonconformity



**avoid water and condensation inside the rotor feeder
drain water as early as possible**

Installation nonconformity



rusty bottom sealing plate



rusty cellular wheel

**the running surface of plates and cellular wheel
to be cleaned up before going into operation
the pockets itself will be cleaned up by the pneumatic feeding**

□ Maintenance on Electrical Panels

□ 对电气原件的维护

- > Break Down Maintenance 故障应急维护

Maintenance on Mechanical Equipment

对机械设备的维护

- > Preventive Maintenance 预防性维护

a: periodic 定期的

b: condition based 基于状态的

Maintenance for panels and mechanics

electric

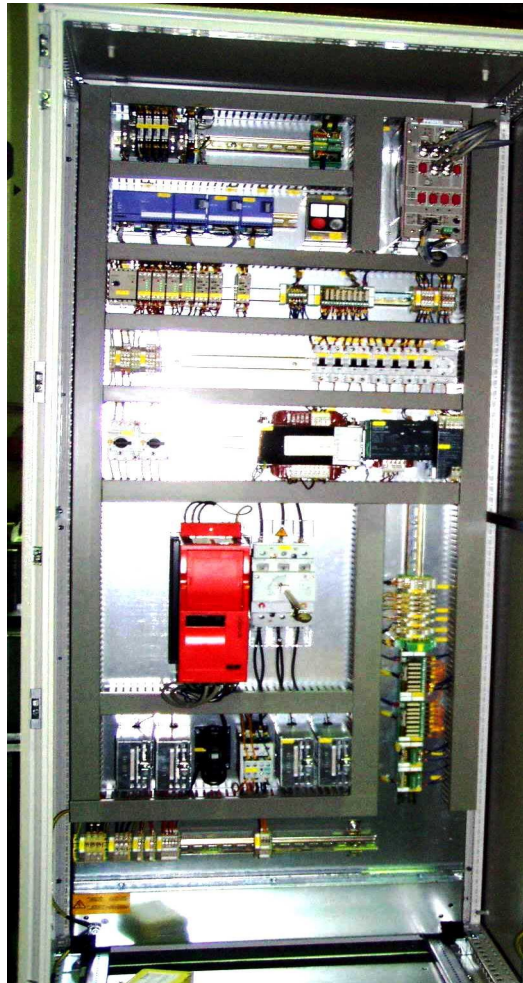

mechanic

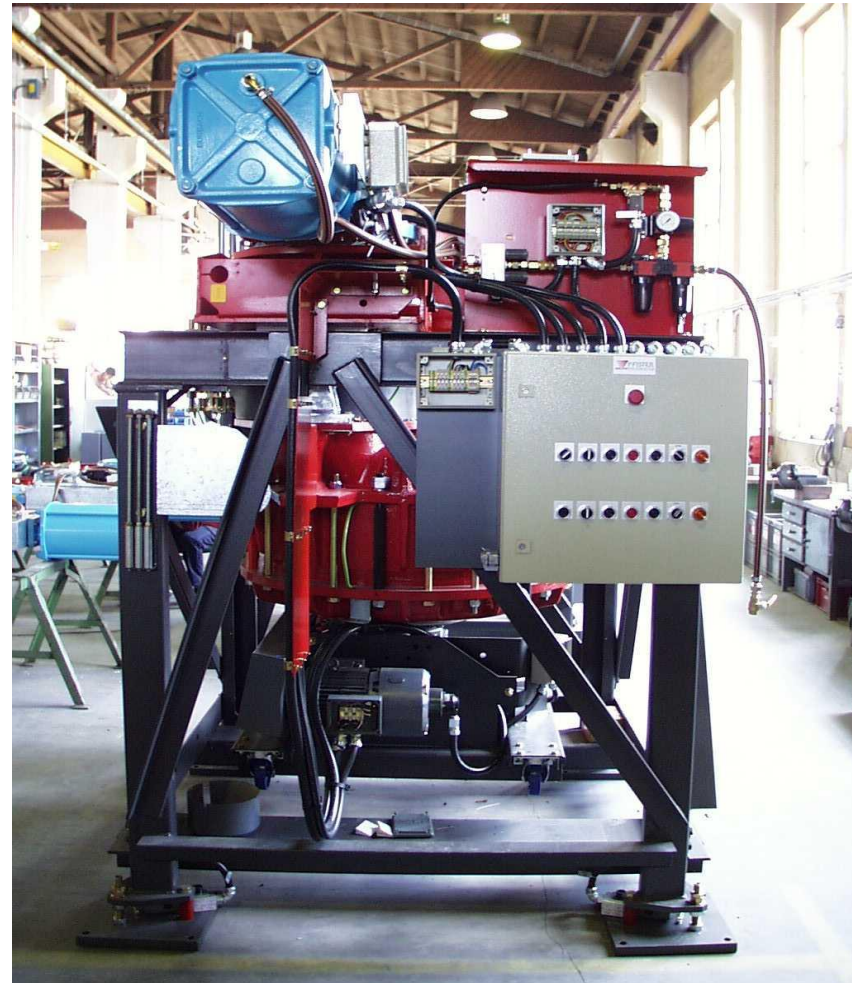

**□ Maintenance on Electrical Panels
- > Break Down Maintenance**

**□ Maintenance on Mechanical Equipment
- > Preventive Maintenance**

a: periodic

b: condition based

Breakdown Maintenance故障应急维修

Simply spoken: do nothing until the CRASH happens
简单的说:事故发生前,什么都做不了。

WHY为什么?

PFISTER 's point of view我们的观点:

- Preventive maintenance is not adequate for most of
预见性的维护不能满足大部分的
 - electrical or电气元件和
 - electromechanical devices机电设备
- Lifetime of these devices acc bathtub curve
这些设备的使用寿命遵循“澡盆”曲线
- Preventive replacement too cost intensive
预见性的更换,导致费用大量增加。

Conclusion结论:

- parts for these components to be stocked on site
这些部分元件要保存在库房里
- parts to be replaced due to break down
及时更换导致故障停机的元件

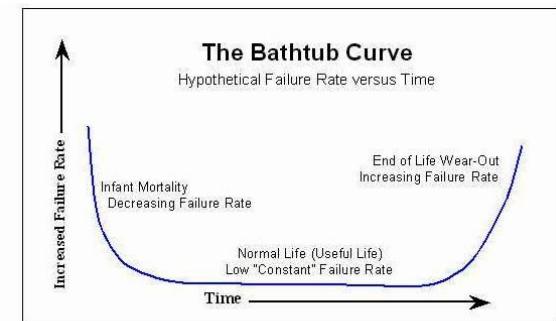
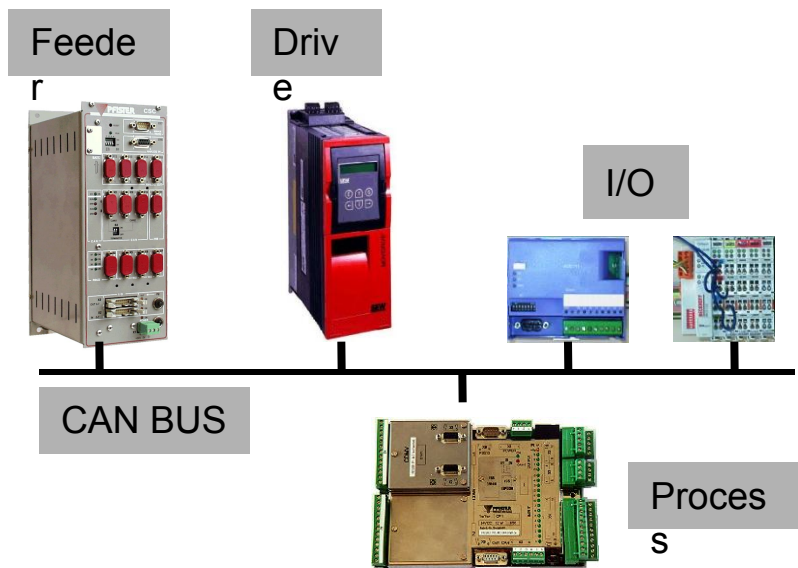

Figure 1: The Bathtub Curve

Electrical and Electromechanical devices 电气和机电设备

- CAN nodes CSC – CPI - Inverter – CAN I/O
- Encoder (speed measuring), drives etc.
- Load cell etc.



encoder
speed
measuring



load cell



drive



**fast access to a.m. spares recommended &
keep parameter backup for programmable devices available**

Maintenance on electrical panels

electrical cabinet

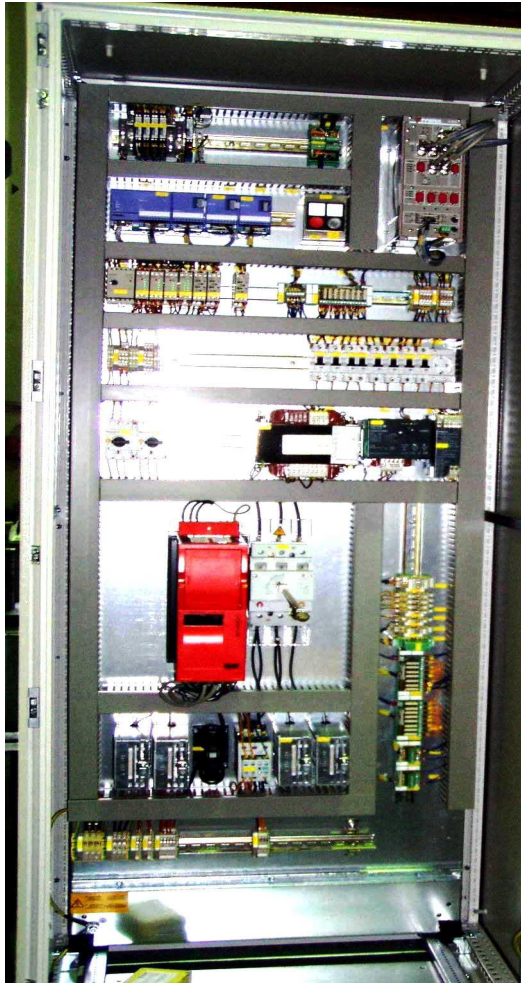

**No special maintenance
or repair required
also no special intervals defined**

Recommendation:

- 1. Keep your data back up available for CSC/Inverter/Schiele or Beckhoff PLC**
- 2. Keep your cabinet clean and dust free**
- 3. Keep the most important electrical spares on stock at site**
- 4. Check during normal shut down calibration of the feeder zero and test weight**

Maintenance on electrical panels

Local control panel with exorbitant dust deposition

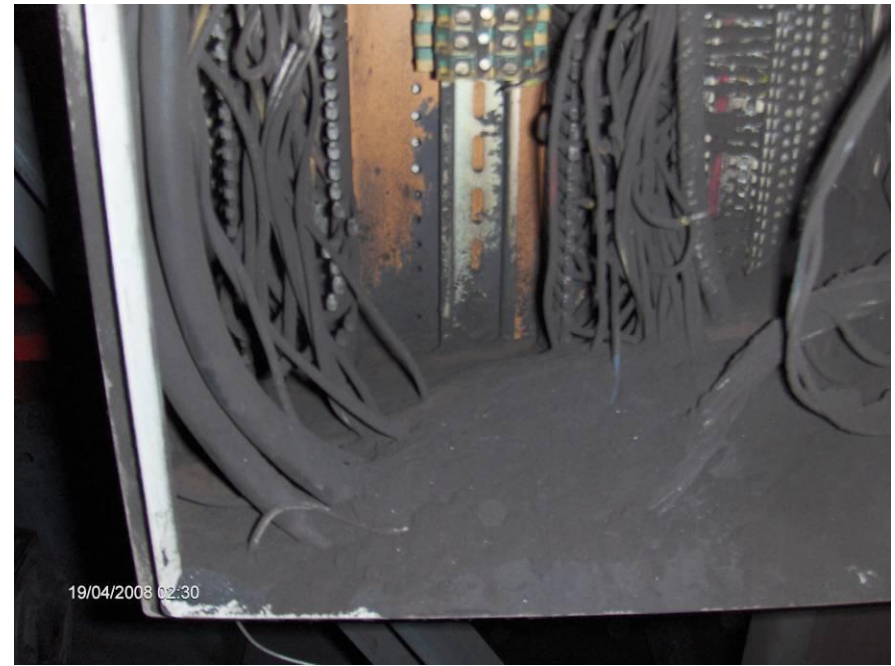
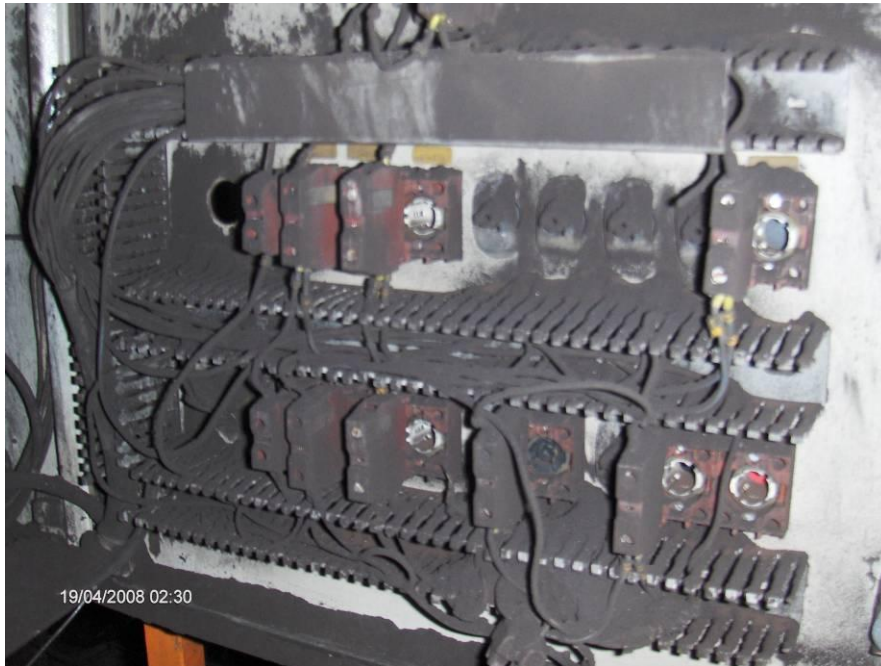

**explosion proof equipment acc. ATEX
local panel doors must be closed during operation
panels to be cleaned on regular basis**

Maintenance on electrical panels

Checking the calibration of the feeder with check weight

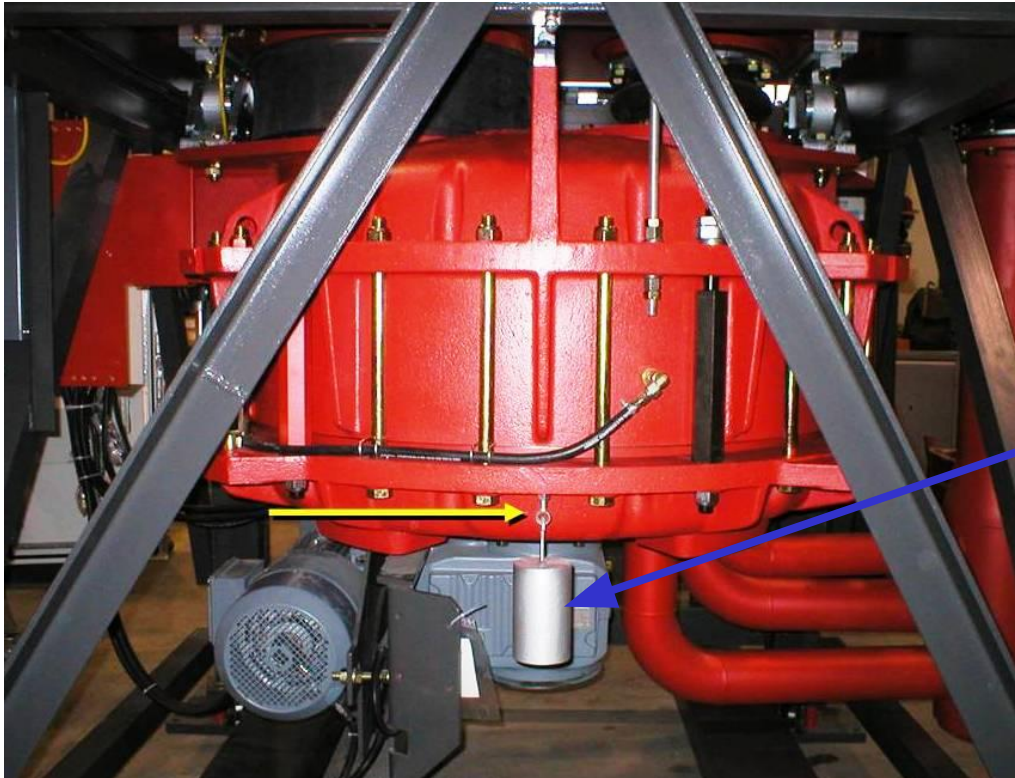

```

CALIBRATION          CSC Node No.  01
Scale
➡ +29,30kg/U Load
   +15,35mV Input Voltage

<..... U50 MC1 amplificat.
<..... 0% MC1 stage dead l
➡ 007,40 kg Check weight
➡ 029,34kg/U Calib.-setpoint
      _Commands: ..... ...
0010663 Calibration fact
0229347 Dead load
  
```

**□ Maintenance on Electrical Panels
- > Break Down Maintenance**

**□ Maintenance on Mechanical Equipment
- > Preventive Maintenance**

a: periodic

b: condition based

Maintenance on mechanical parts

MAINTENANCE INSTRUCTIONS

Rotor Weighfeeder DRW 4.10/4.12/4.14



TRM / 29.07.2005

550.096.60.04-WA-b-GB

ROTOR WEIGHFEEDER DRW 4.10/4.12/4.14

Contents.....	Page
1 Important instructions	2
2 Lubrication points.....	3
3 Lubrication intervals and lubricants.....	4
4 Lubricating instruction.....	5
4.1 Helical-Bevel Gear Unit.....	5
4.2 Helical Gear Unit.....	5
4.3 Drive motor.....	6
4.4 Bearings, drive shaft.....	6
4.5 Seal, drive shaft.....	6
4.6 Driver and rotor hub.....	6
4.7 Weighing axis bearings.....	6
4.8 Lever bearing weighing device.....	6
4.9 Oil damper weighing device.....	6
4.10 Compressed air oil mister.....	6
5 Maintenance points.....	7
6 Maintenance intervals.....	8
7 Maintenance work.....	9
7.1 Check the rotor weighfeeder for settled dust and leaks.....	9
7.2 Check the bearing for unusual noises.....	10
7.3 Air supply.....	10
7.3.1 Filter water separator (191).....	11
7.3.2 Oil mister (193).....	11
7.3.3 Compensator flushing.....	11
7.3.4 Outer chamber flushing.....	11
7.4 Weighing device.....	12
7.4.1 Cleaning and check the weighing device.....	12
7.4.2 Checking the smoothness of operation.....	13
7.4.3 Checking and adjusting the zero point.....	13
7.4.4 Checking the calibration.....	13
7.5 Adjusting the rotor gap.....	14
7.5.1 Checking and adjusting the rotor gap when the rotor is stationary.....	14
7.5.2 Checking and adjusting the rotor gap during operations.....	15
7.6 Rotor, sealing plates.....	15
7.7 Compensators: check condition, replace if necessary.....	16
7.8 Check the seal (drive shaft) and replace if necessary.....	17
7.9 Gear unit.....	17
7.10 Three-phase motor and tacho-generator.....	17
7.11 Belt drive.....	18
7.12 Material shut-off gate.....	19
8 Index History.....	19

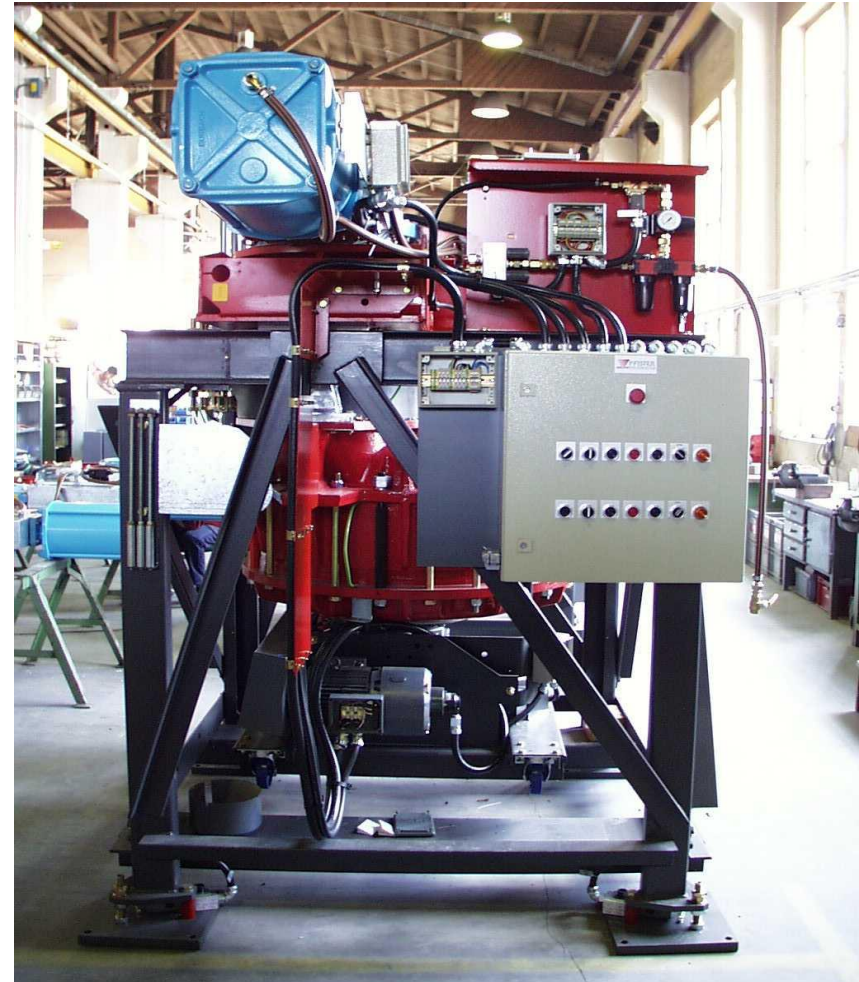

Maintenance instructions

MAINTENANCE INSTRUCTIONS

Rotor-Weighfeeder-DRW-4.10/4.12/4.14

TRM-/29.07.2005

550.096.60.04-WA-b-GB

6 → Maintenance intervals

No.	Maintenance activities	1 T	1 M	3 M	6 M	12 M	24 M	36 M	60 M
7.1	Check the rotor weighfeeder for settled dust and leaks. If necessary, clean off the dust and seal the leaks.	x	*	*	*	*	*	*	*
7.2	Check the bearing for unusual noises.	x	*	*	*	*	*	*	*
7.3	Air supply: Filter-water separator: drain condensate Filter-water separator: clean the filter Compensator flushing: Check flushing pressure	← x #	← ← x	*	*	*	*	*	*
7.4	Weighing device: cleaning check and adjusting	*	← x	*	*	← ← x (1)	*	*	*
7.5	Adjusting the rotor gap	*	x	x	*	*	*	*	*

□ Lubrication 润滑

case: shaft sealing and bearing 轴密封和轴承

□ Weighing device 称重机构

case: damper oil tank 阻尼油盒

□ Air supply 空气气源

case: outer pocket cleaning 转子外侧腔体清洗

case: compensator cleaning 补偿器的清洗

case: mixing up outer pocket and compensator cleaning
转子外侧腔体清洗和补偿器的清洗

□ Adjusting the rotor GAP 调整转子的间隙

□ Blow out nozzle 出料嘴

case: high inner chamber wear 内腔的高磨损

Maintenance on mechanical equipment

□ Blow out nozzle

case: high inner chamber wear

case: best air distribution adjustment

□ Drive Belt

case: correct adjustment

□ Wear rating

case: condition of sealing plates
and cellular wheel

□ Professional Rework



We take care of your wear!

Professional rework
of your feeder wear parts



PFISTER
WEIGHING • DOSING • CONTROL



FLSMIDTH

□ Lubrication

case: shaft sealing and bearing

Maintenance - Lubrication

MAINTENANCE INSTRUCTIONS		
Rotor-Weighfeeder-DRW-4.10/4.12/4.14		
TRM-/29.07.2005		550.096.60.04-WA-b-GB

→ Lubrication-intervals-and-lubricants

Lubrication point	Designation	Lubricant change	Lubricant	Amount per lubrication point		Lubrication interval	Change lubrication	Works-filling		Remarks	
				1-st filling	Recharge			Site-filling			
No.	Amount										
1	1	Helical-Bevel-Gear-Unit KAF-87	Gear-oil Roller-bearing-grease Sealing-rings	VG-220 SHC100	8,0	8,0	---	20.000	x	--	At latest after 5-years
1	1	Helical-Bevel-Gear-Unit KAF-97	Gear-oil Roller-bearing-grease Sealing-rings	VG-220 SHC100	15,7	15,7	---	20.000	x	--	At latest after 5-years
1	1	Helical-Bevel-Gear-Unit KAF-107	Gear-oil Roller-bearing-grease Sealing-rings	VG-220 SHC100	24	24	---	20.000	x	--	At latest after 5-years
2	1	Helical-Gear-Unit	Gear-oil Roller-bearing	VG-220 SHC100	0.8	0.8	---	20.000	x	--	At latest after 5-years

using the correct lubricant and observation of the lubrication interval extend the lifetime of your equipment

Lubrication shaft sealing and bearing



shaft bearing 轴承
each 1000 oh (~40d)
possible during operation
in adjust mode or during a
short outage

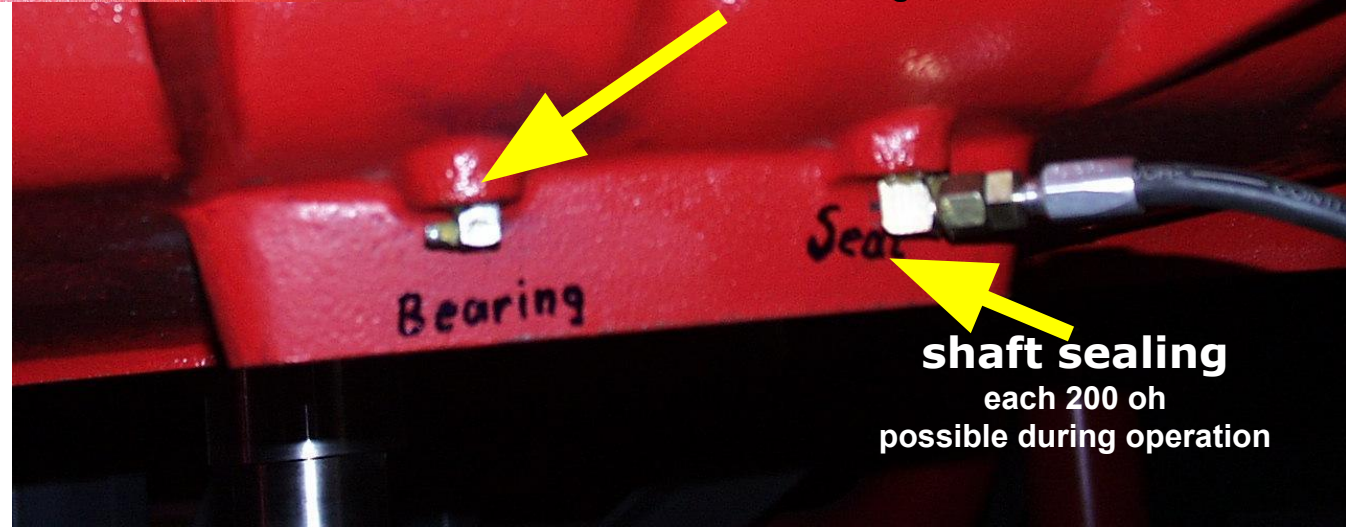

shaft sealing
each 200 oh
possible during operation

Lubrication problems

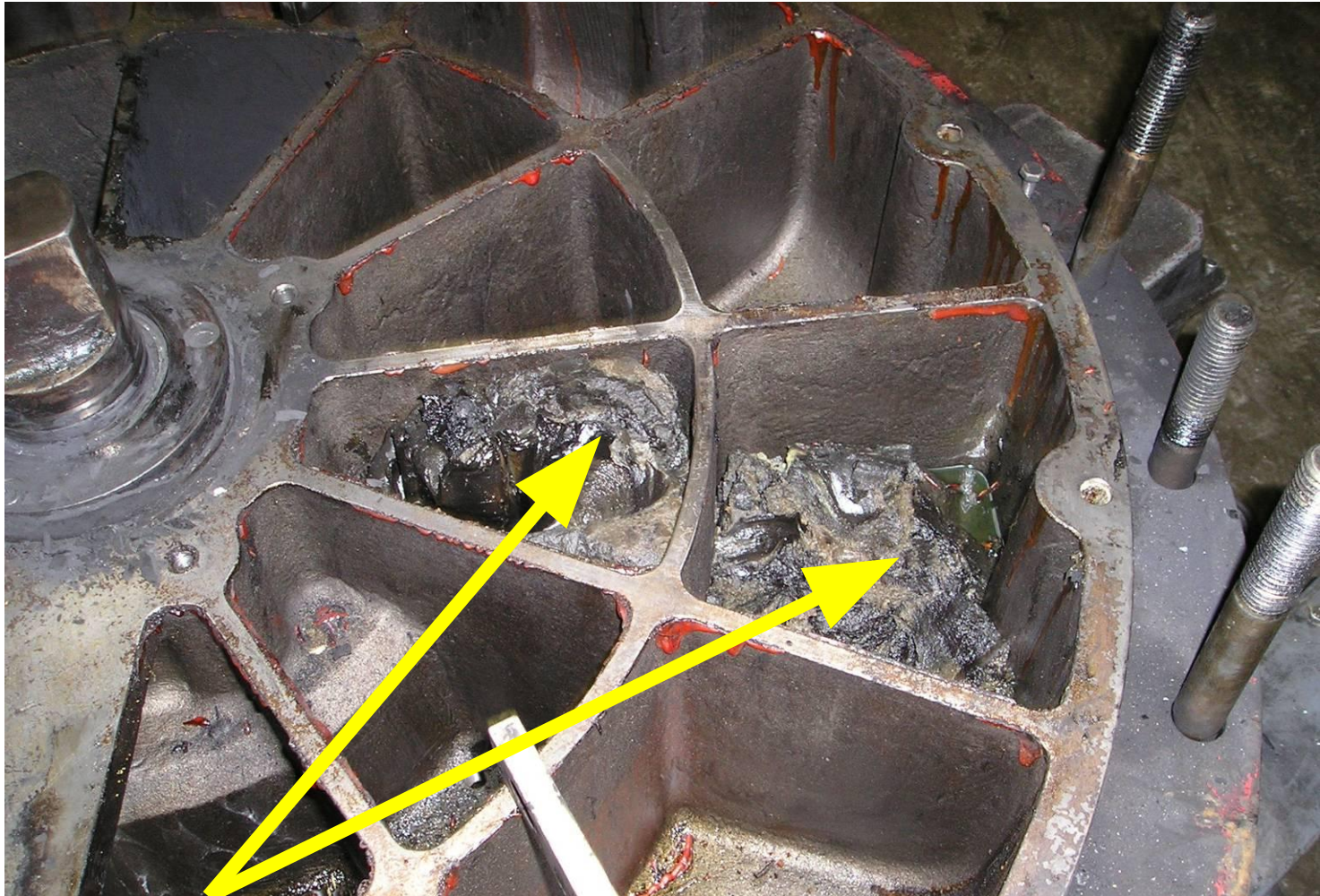

**exorbitant greasing to be avoided such as too less greasing
Openings in the casing are blocked which leads to a wrong zero point**

damages of drive shaft

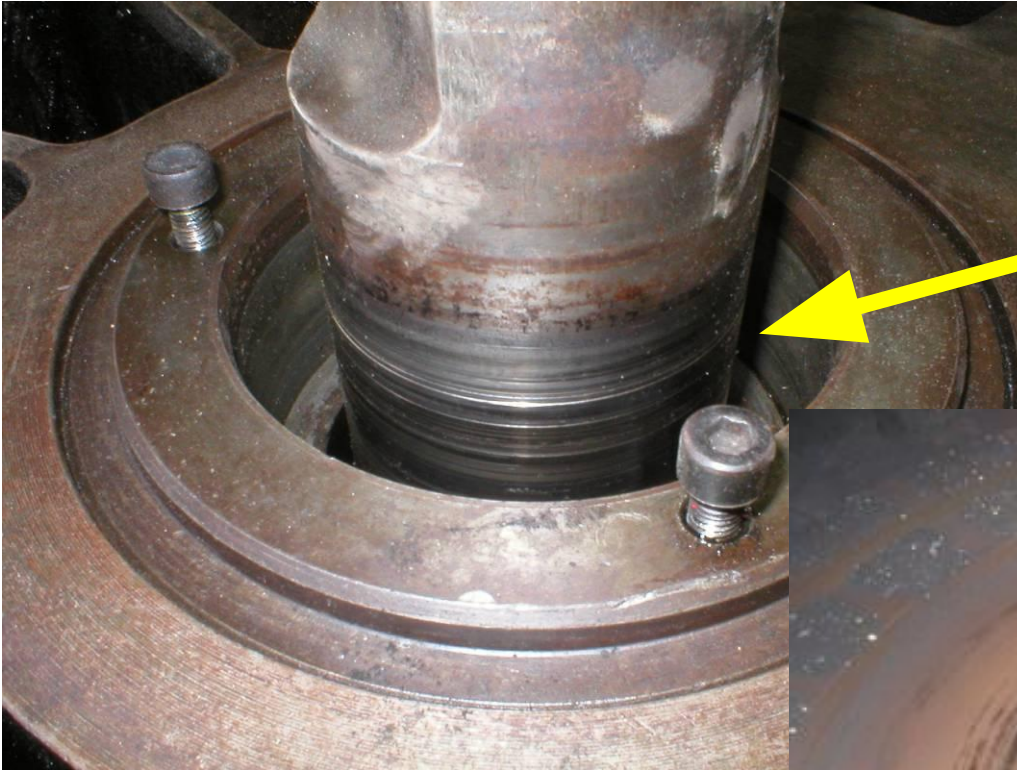

high wear at the shaft:

REASON:

- non original sealing rings (PTFE)
- insufficient lubrication

CONSEQUENCES:

- damage of shaft
- damage of bearing



jammed coal at the shaft:

REASON:

- excessive lubrication

CONSEQUENCES:

- lift up of wheel
- rotor jamming

damages of the drive shaft

high wear at the shaft



REASON:
non original sealing rings (PTFE)
insufficient lubrication

CONSEQUENCES:
damage of shaft
damage of bearing

shaft sealing kit

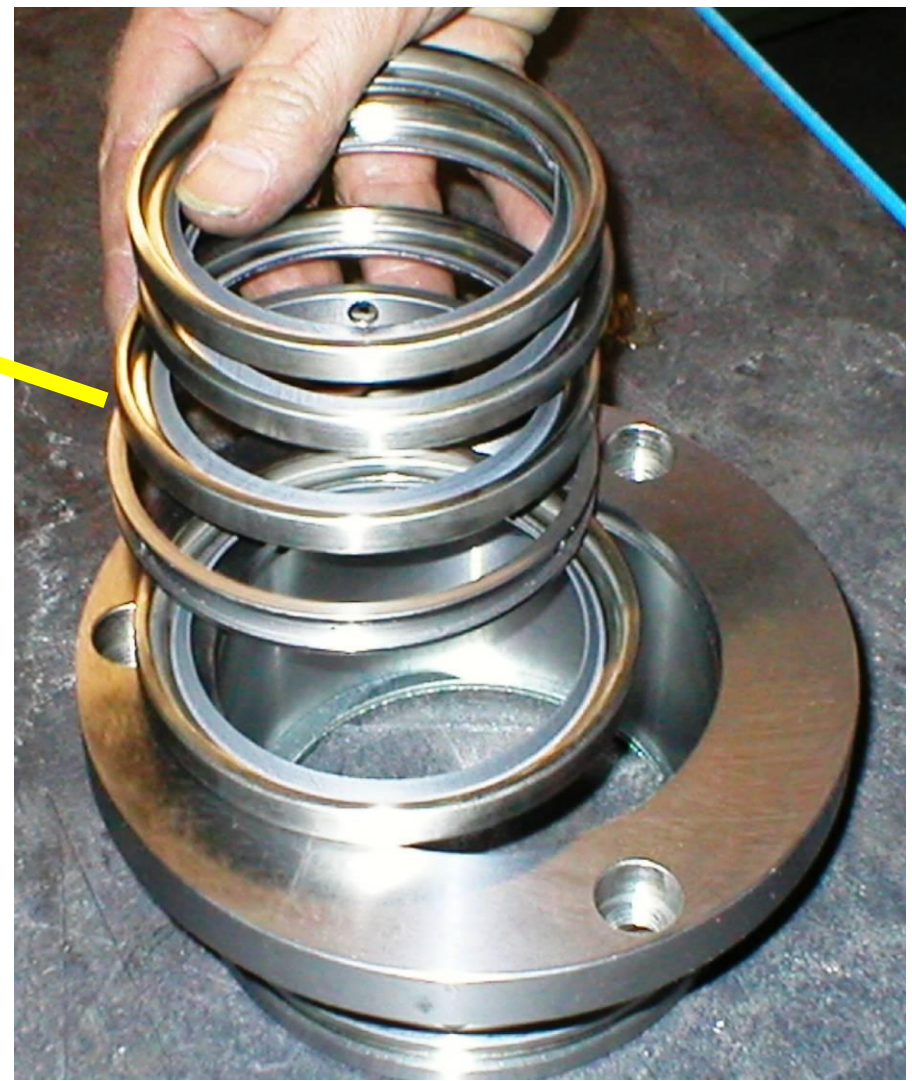
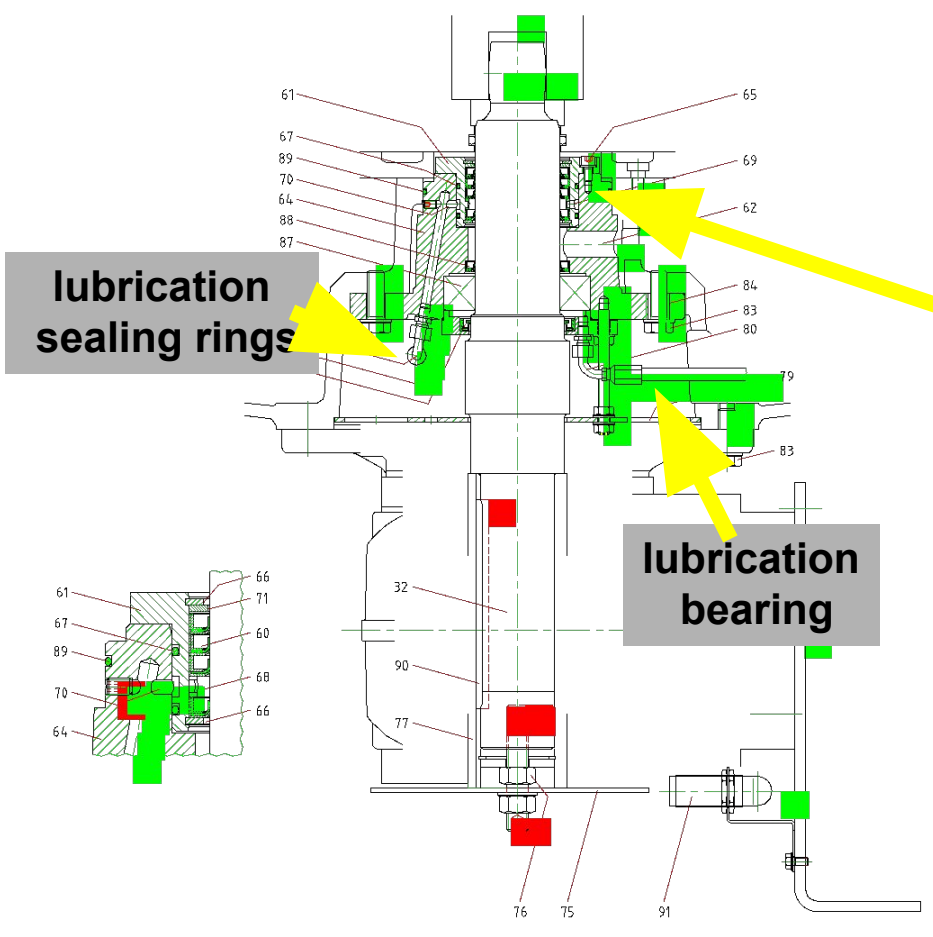

**take care of the correct installation
of the sealing rings**

shaft sealing kit

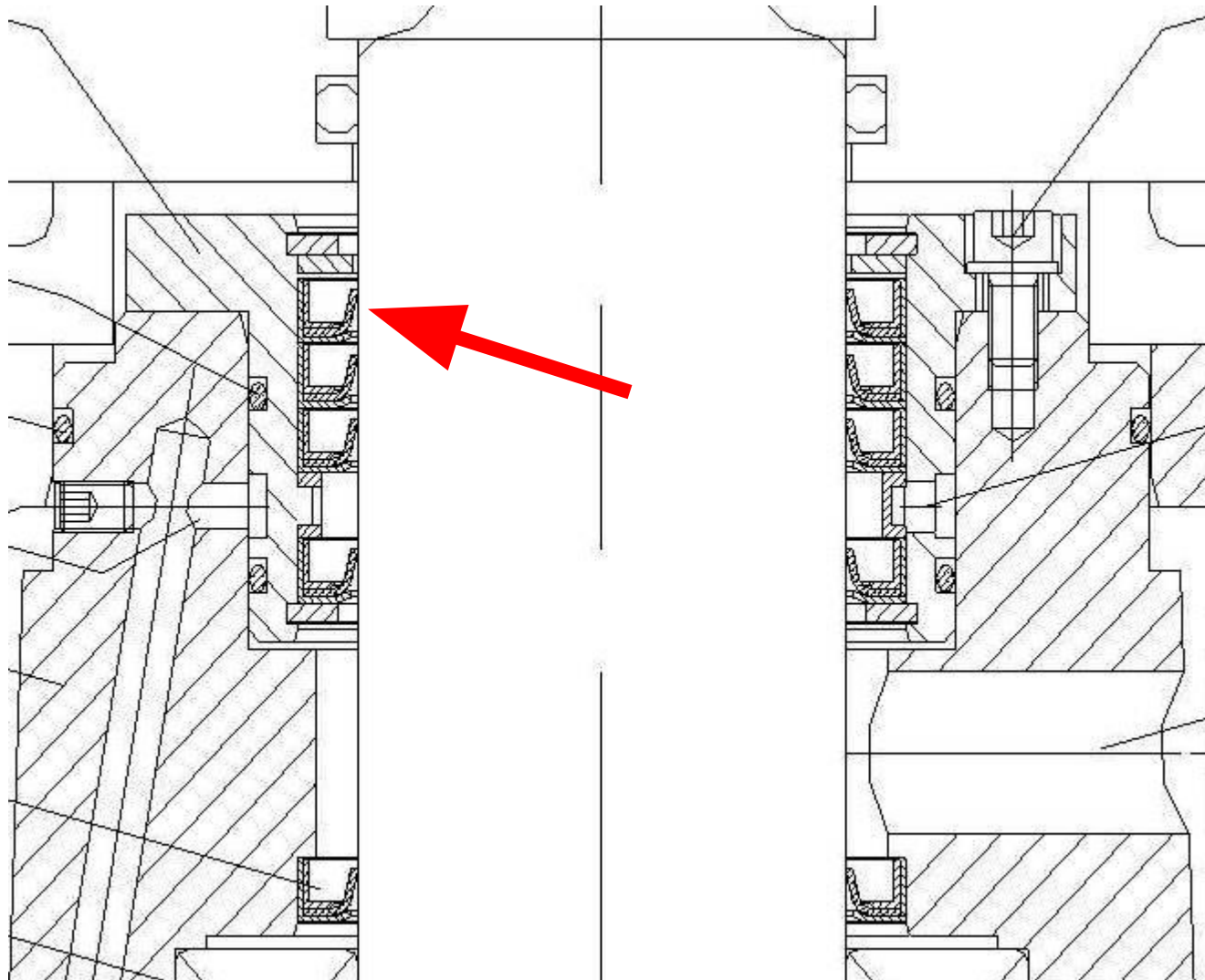

take care of the correct installation of the sealing rings

□ Weighing device

case: damper oil tank

Weighing device – oil damper

Weighing device

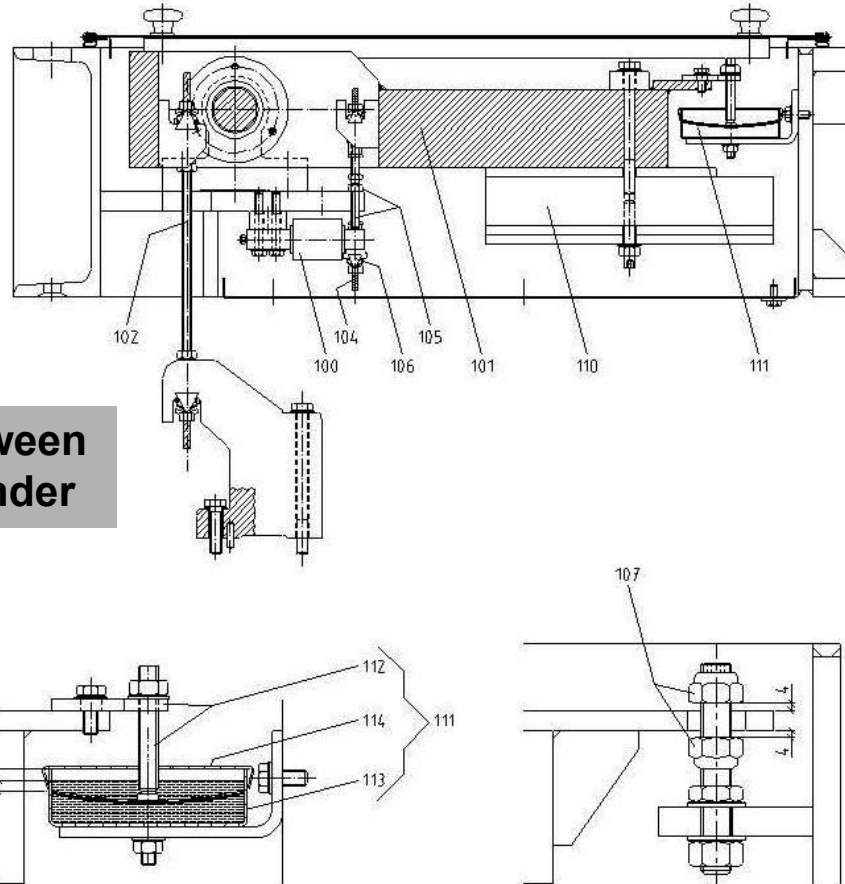

clearance 0,4 mm between damper disc and cylinder

Check the smoothness of operation of the weighing device at the stop nuts (107), the overload screw (105), the suspension pieces (102 and 104) and at the locking rod on the housing

Figure 4: Weighing device

do not brush dirt into the oil damper while cleaning

Weighing device – oil damper

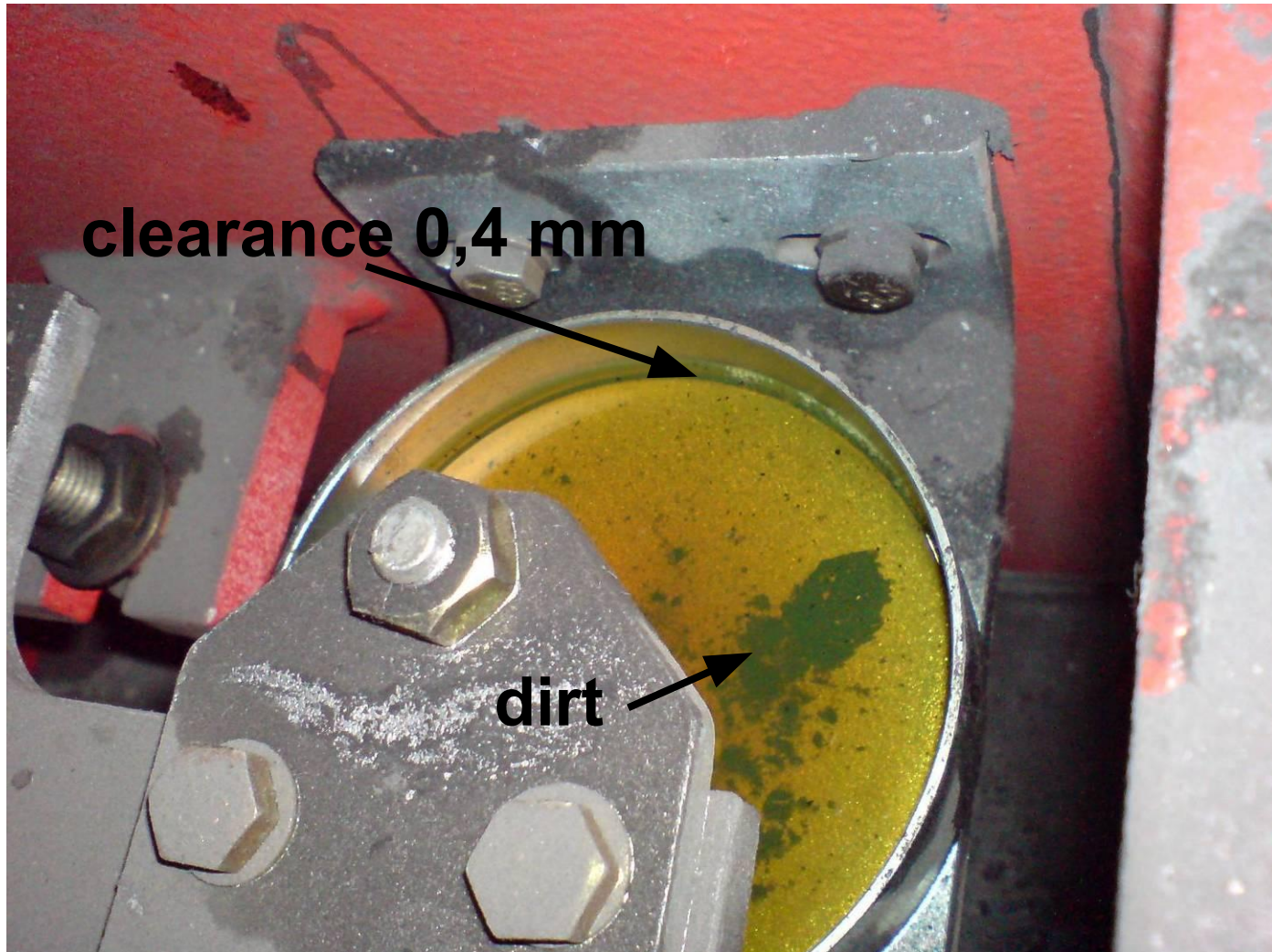

dirt in the oil (damper) influences the free moving and causes measuring errors

Weighing device – oil damper



Maintenance situation to be improved to avoid measuring errors

Weighing device – locking screw



**The locking rod must enable free movement
the locking rod is a potential reason in case of wrong measuring values**

□ Air supply

case: outer pocket cleaning

case: compensator cleaning

case: mixing up outer pocket and compensator cleaning

Air supply requirements

7.3 Air supply

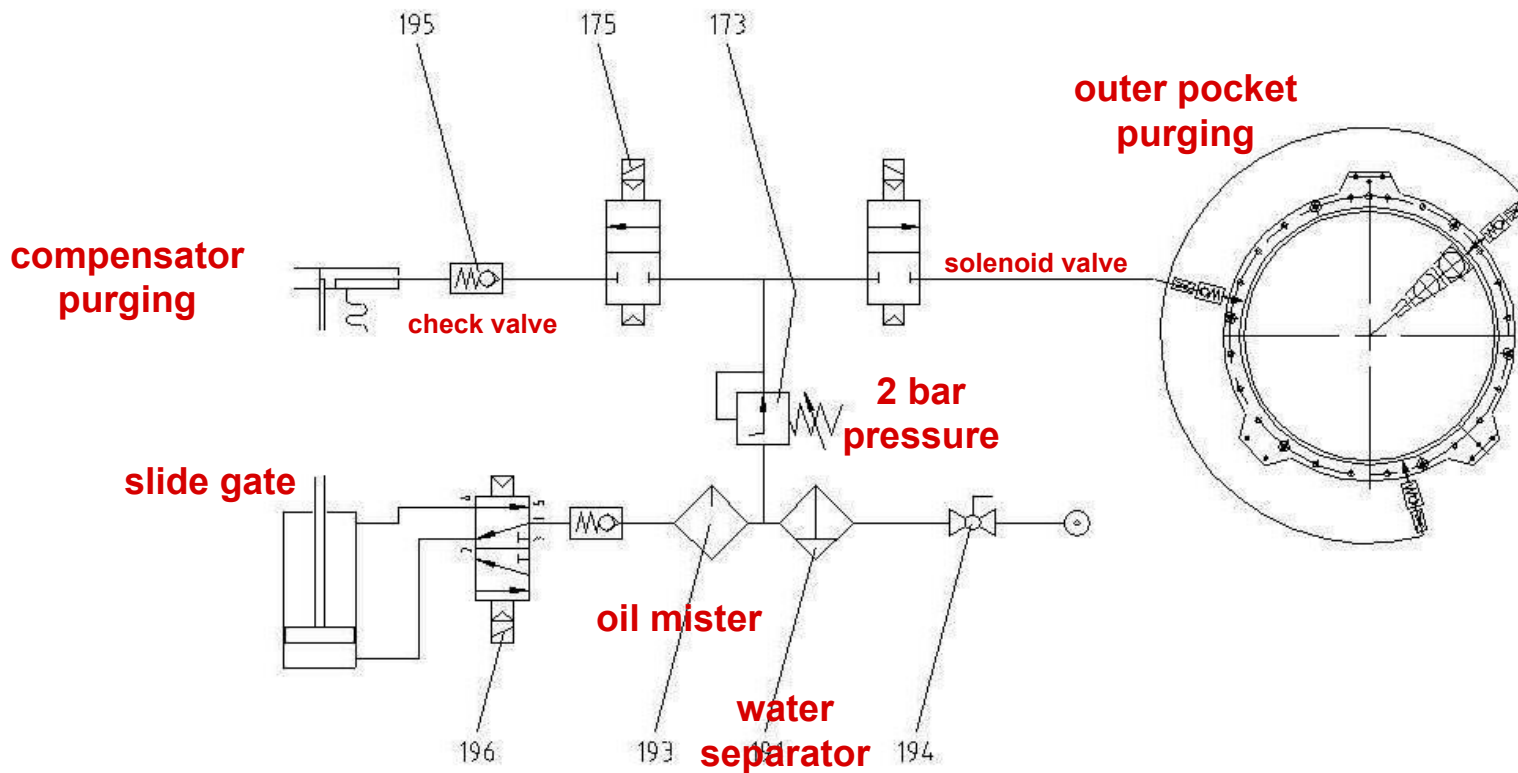
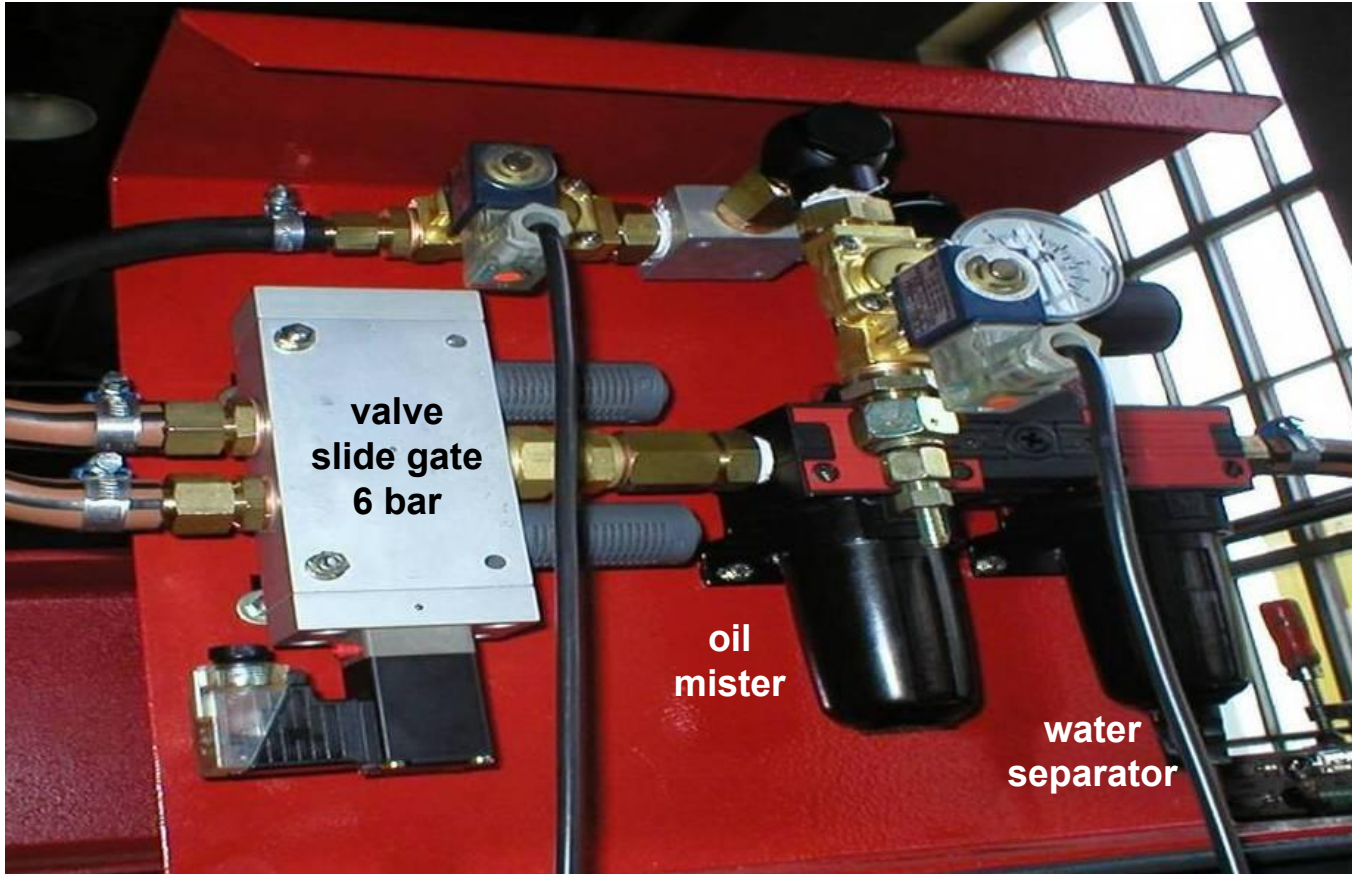

Figure 3: Air supply

compressed air from the industrial supply (6 bar)
compressed air must be purified, technically dry and free of oil

Air supply - pneumatic unit



pressure control valve should be adjusted at 2 bars

cyclic compensator purging
20 min OFF
2 min ON

permanent outer pocket purging

regular inspection, drain water, check pressure

simple equipment with high impact on operational functionality

Air supply - pneumatic unit



Maintenance situation to be improved to come back to reliable functionality

pneumatic unit and filter plates

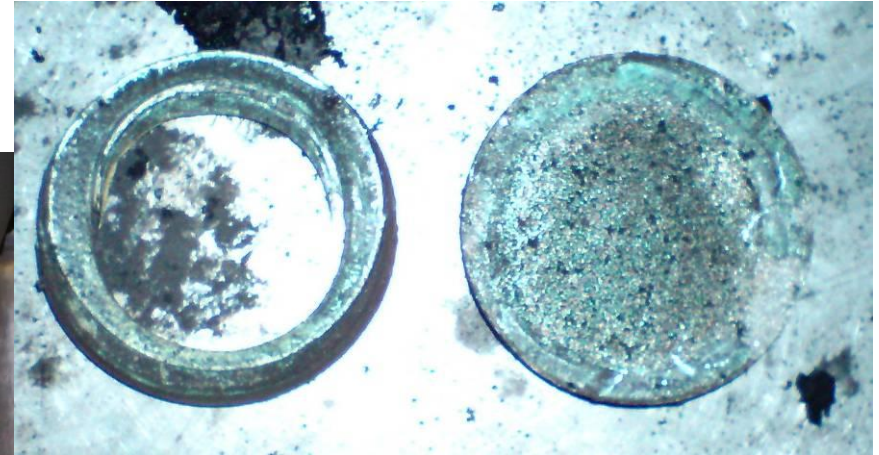

**check air permeability of sinter plates
recommended pressure at 2bar
normally controlled by impulse/pause, occasionally permanent**

Water and rust in the air supply

Wear on sinter plates causes bad material flow

Material clogging wherever air should supply the material flow

- inlet flexible joint due to purge air connection
- outer pocket due to purge air for outer pocket cleaning

Wrong adjusted air supply

Damage of the „metallic“ inlet flexible joint

- caused by wrong adjustment of the air pressure -> correct is 2 bar
- caused by wrong adjusted impulse/pause time -> correct is 20 min OFF, 2 min ON (time relay or CSC timer)

rotor jams caused by caked outer pockets



Gap? Fineness?

indication: slowly increasing motor current after opening and cleaning

rotor jams caused by caked outer pockets

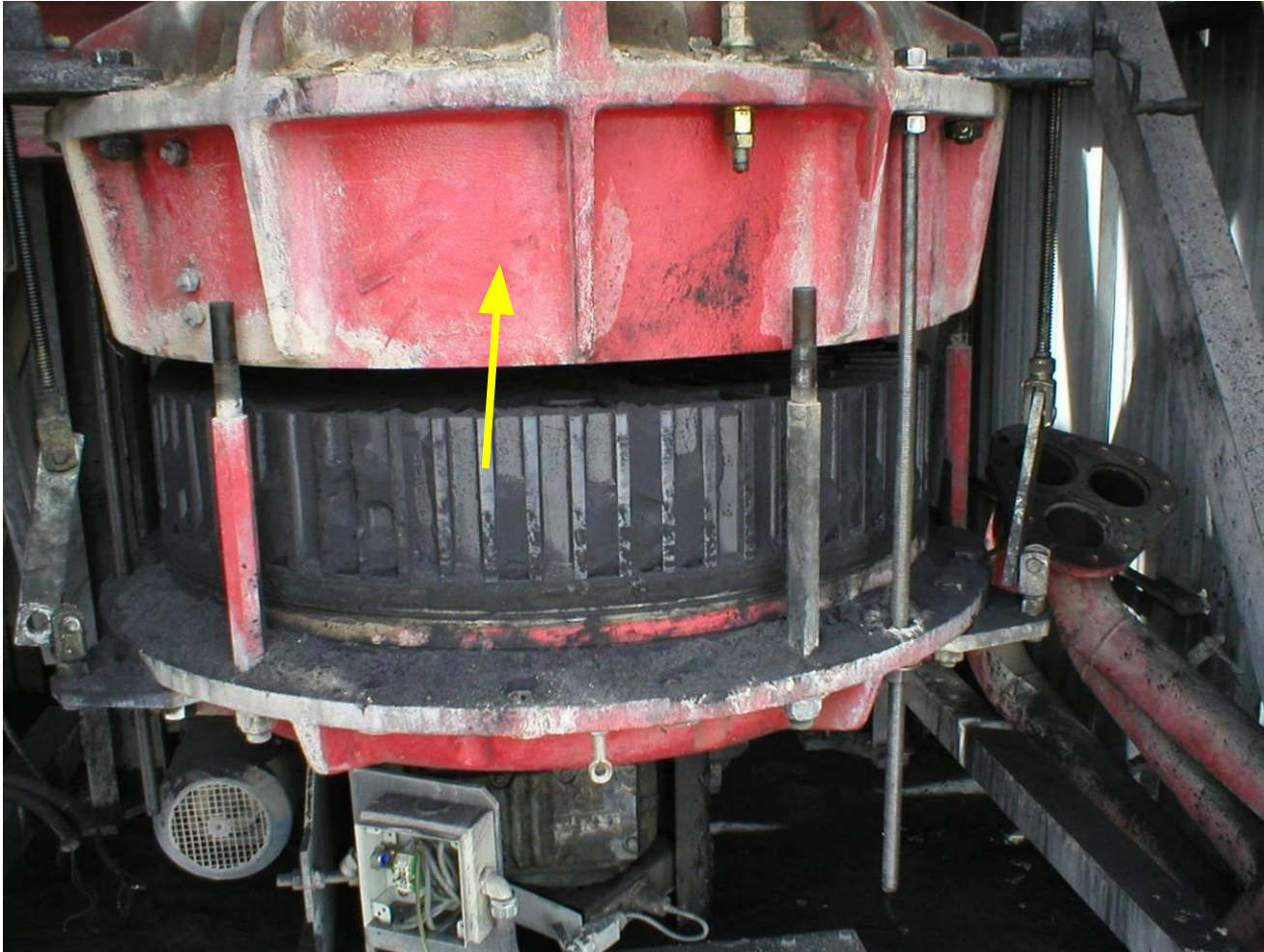

**missing outer pocket aeration
effect like a drum brake**

purge air for outer pockets cleaning

deflector plate

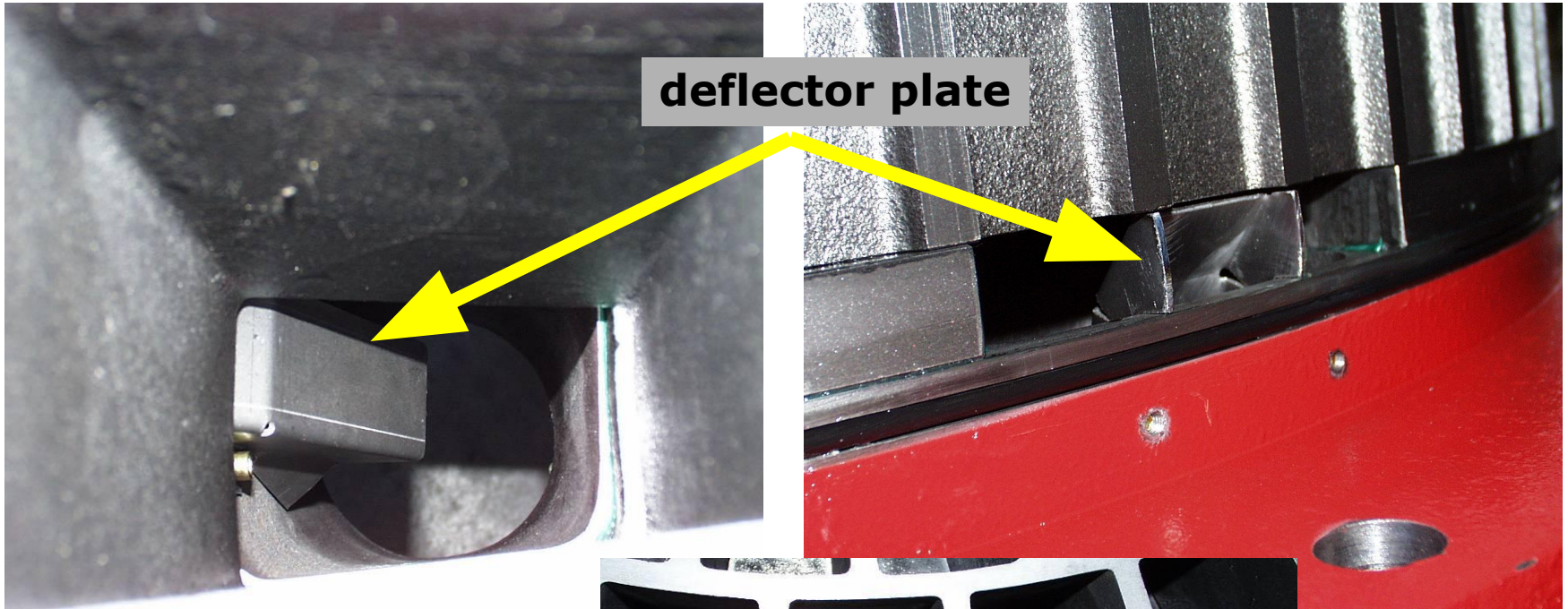

**balancing weights
from outside into the
feeding pocket**

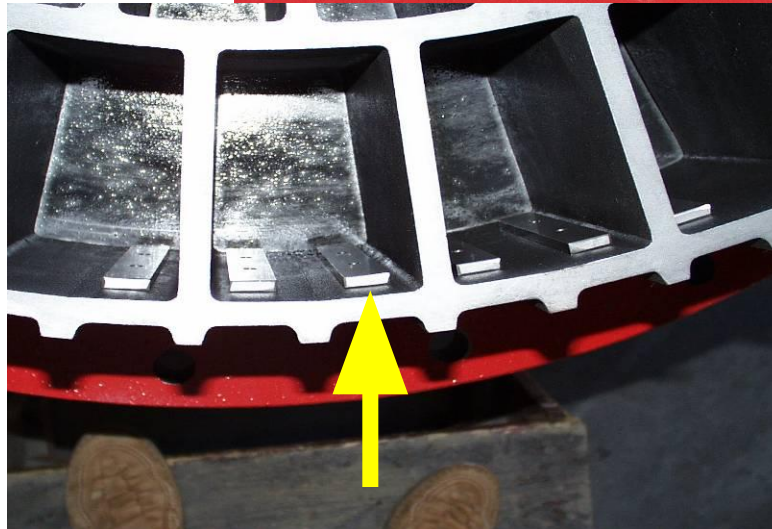

purge air for outer pockets cleaning

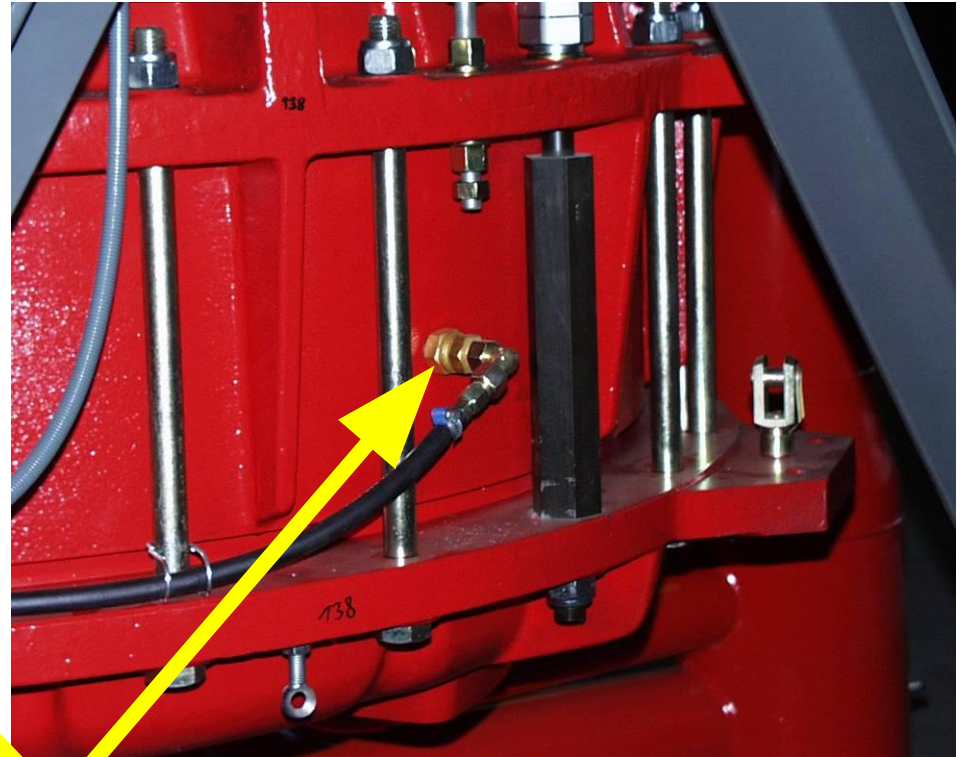
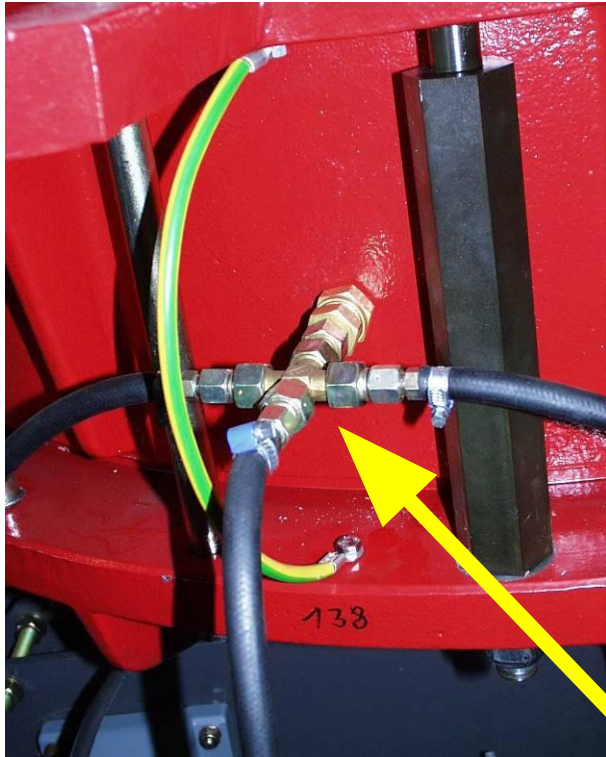

**installation of purge air at the circumference
3 check valves, pressurized by approx 0,7 bar**

Typical wear - blow out nozzle



Wear especially coming from the outer chamber purge air stream

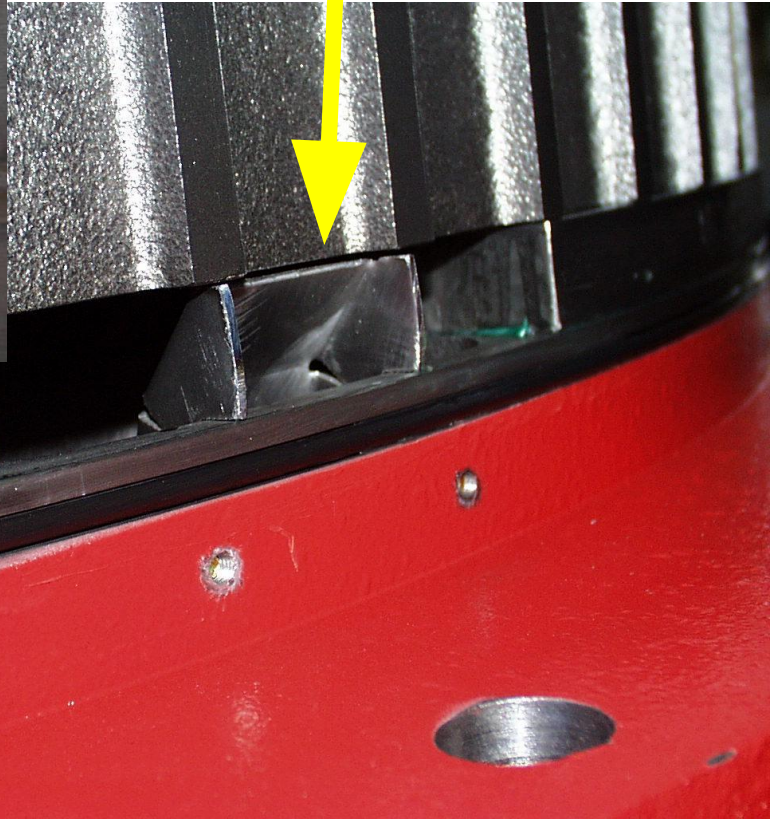
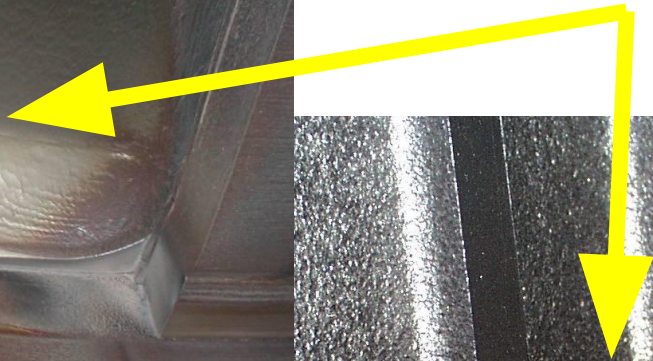

What to do?

Typical wear - blow out nozzle

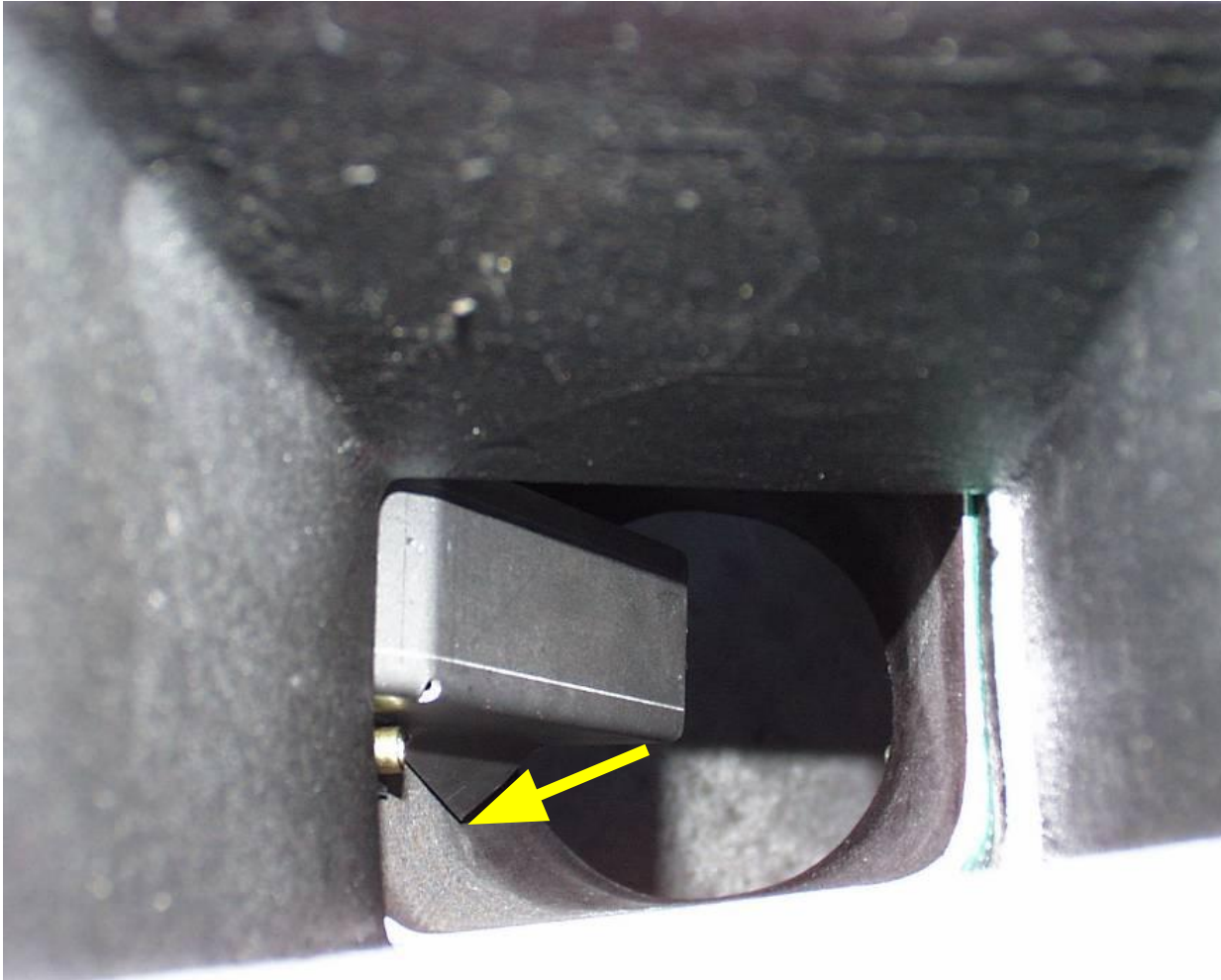

Counter measurements: reduce active area

Permanent or cyclic purging



2 min ON 20 min OFF time

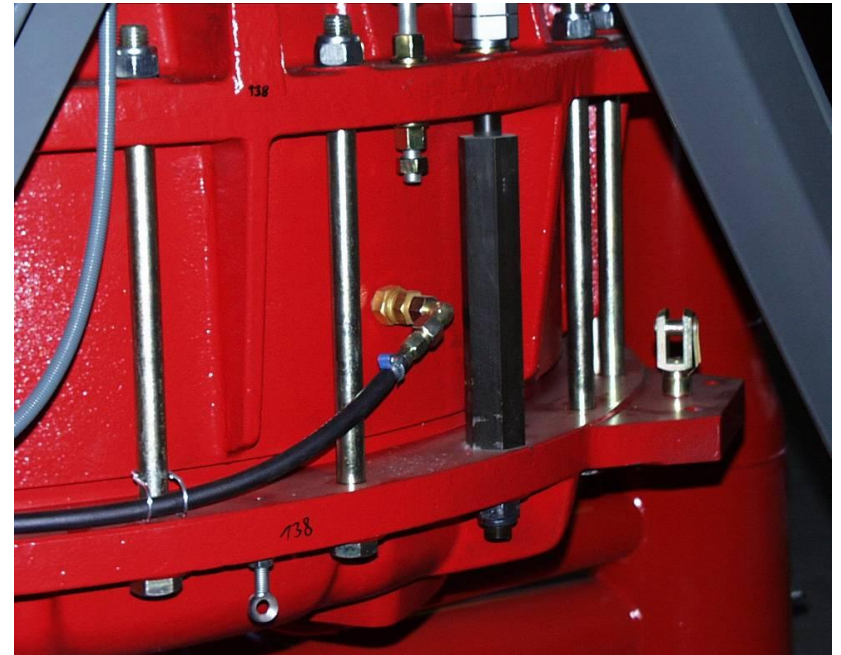

permanent ON

installation failure mixing up purge air for
inlet compensator and outer pocket cleaning
with **high impact**

inlet compensator (flexible joint)



**inlet compensator blown through
by excessive purging air (interval and pressure)**

inlet compensator (flexible joint)

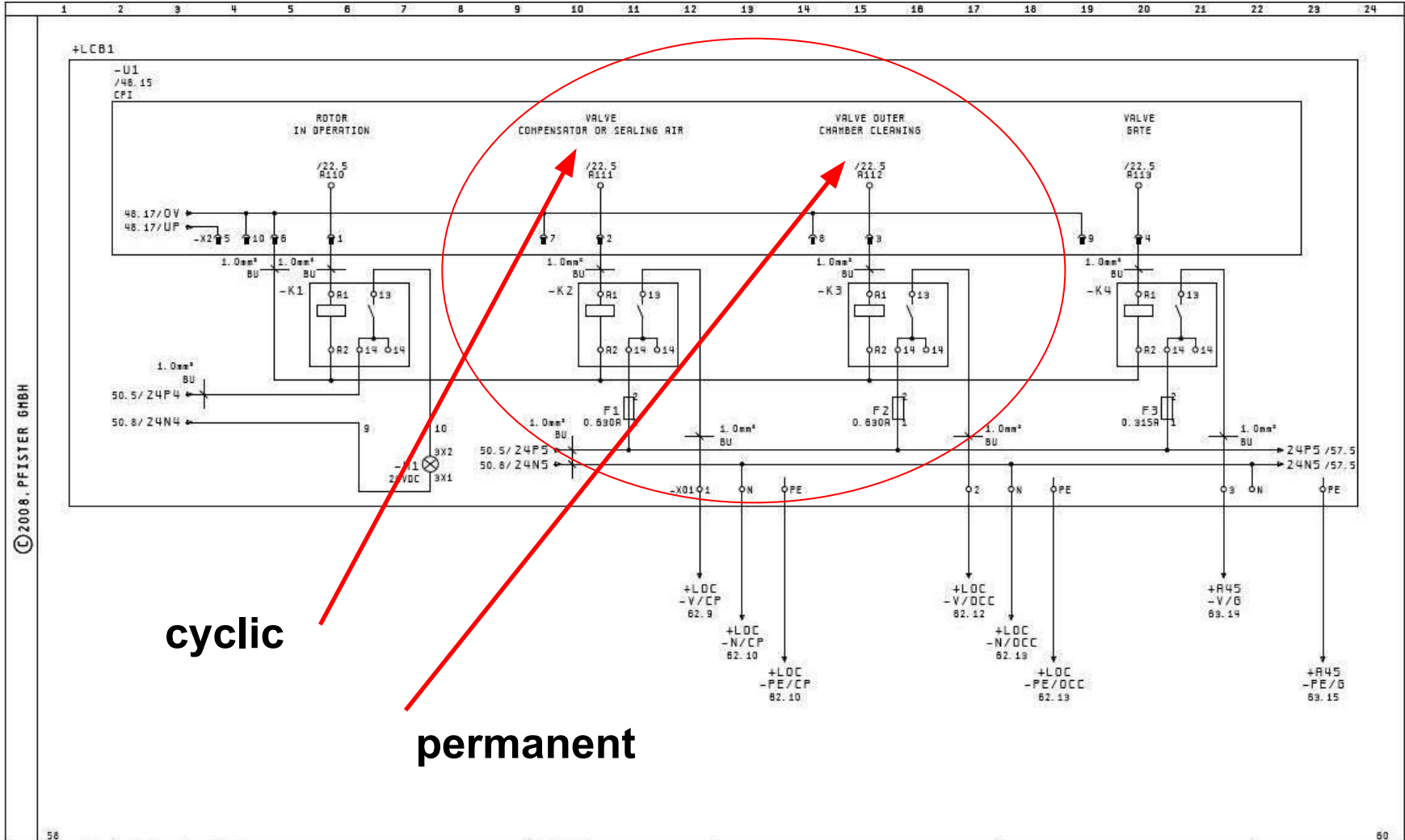

58			60				
Index	Alternation	Date	Check	Reference	Denomination	Plant: Anhui Province Frecalcinar #5	=CZ06_02
				Anhui Chizhou Conch #0 & #7	CPI-OUTPUTS R110-R113		+LCB1
				Order No.: DOR8 2788			Page 59
				Drawn No.: 022.2788.1000-6E-0-6B	Drawn 2008-10-30 Sohlar		of 71 Pg. 6B
					Check	Ex	Source: 02788R1 Daw: TRE

inlet compensator (flexible joint)



old design: adjustment purge interval by time relay impuls - pause

new design: no adjustment, fix intervals implemented in CSC PLC

□ Adjusting the rotor GAP

Adjusting the rotor gap

7.5 Adjusting the rotor gap

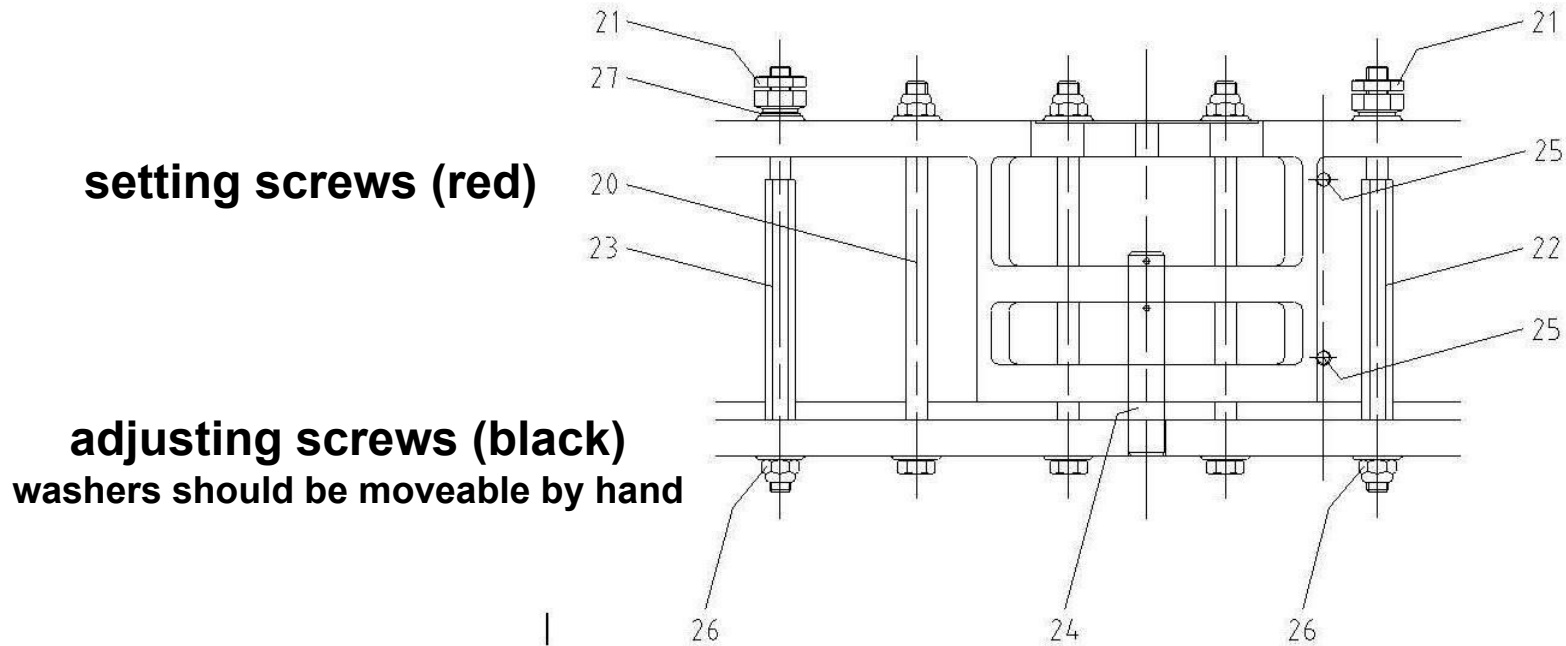

Figure 5: Adjusting the rotor gap

**screws between lower and upper housing
gap should be 0,4 mm**

Adjusting the rotor gap



setting screws (red)
for correct gap adjustment 0,25 mm

adjusting screws (black)
washers should be moveable by hand

screws between lower and upper housing (brassy)
gap should be 0,4 mm

GAP adjustment

Checking and adjusting upper gap with feeler gauge

Precondition:

- rotor not in operation
- rotor empty

Advantages:

- correct knowledge about upper and lower gap
- give information about condition of plates/wheel



Measuring/inspection holes

Adjusting the gap during operation with current indication

Precondition:

- rotor in operation and adjust mode activated -> loading frozen

Procedure :

- decreasing gap until current increases
- deselect adjust mode

Advantage:

- adjustment without shut down
- achievable min gap

Disadvantage:

- gap dimensions unknown

Best adjustment:

1. With feeler gauge
2. Fine adjustment over motor current

GAP adjustment



Use your regular outages for a quality check of your feeder GAP

**Lower gap not adjustable, should be less than 0,1 mm
upper gap adjustable, should be approx 0,25 mm**

**In case of bad gap values prepare your spare parts for your
next scheduled outage**

GAP adjustment – important summary

Consequences of a bad (> 0.3 mm) adjusted upper gap



Material flushing to inner and outer pockets

- > high wear in the blow out nozzle - inner chambers
- > jamming if material moves into the outer chambers



Material flushing directly from inlet to outlet

- > unreliable measuring results
- > drifting accuracy



High amount of leakage air from the feeding pipe to inlet up to the downpipe and the silo

- > bad material flow into the feeder
- > requested higher feedrate can not be reached

Consequences of a wide lower gap (> 0.1 mm not adjustable)



Material are sticking between lower plate and wheel

- > wheel is lifted up
- > lifted wheel can lead to rotor jams

**Take regular care of your gap, check at a normal shut down
have an exchange set (plates and wheel) available
rework/remachine your 2nd set during using your 1st set**

□ Blow out nozzle

case: high inner chamber wear

case: best air distribution adjustment

Blow out nozzle

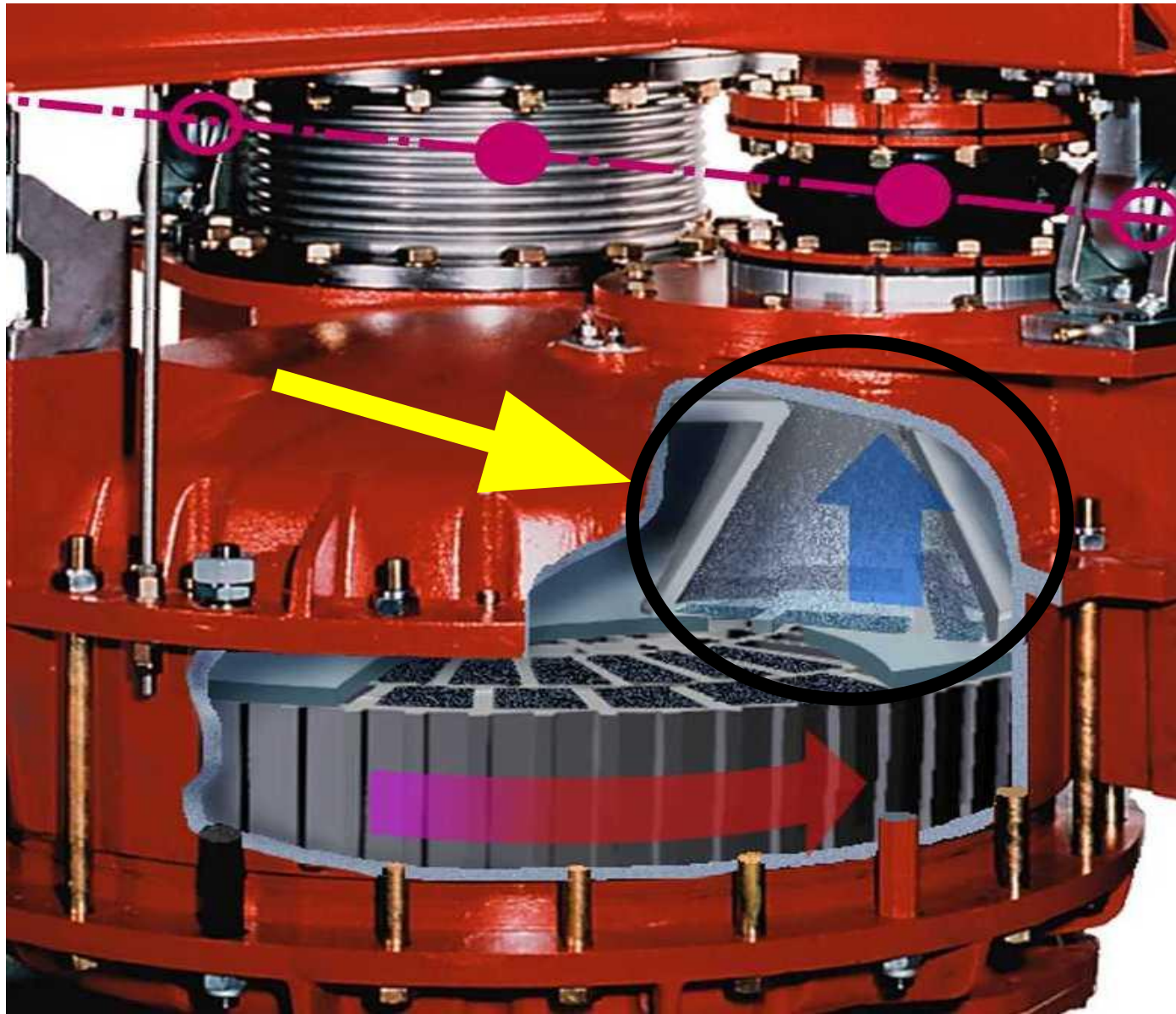

Blow Out Nozzle

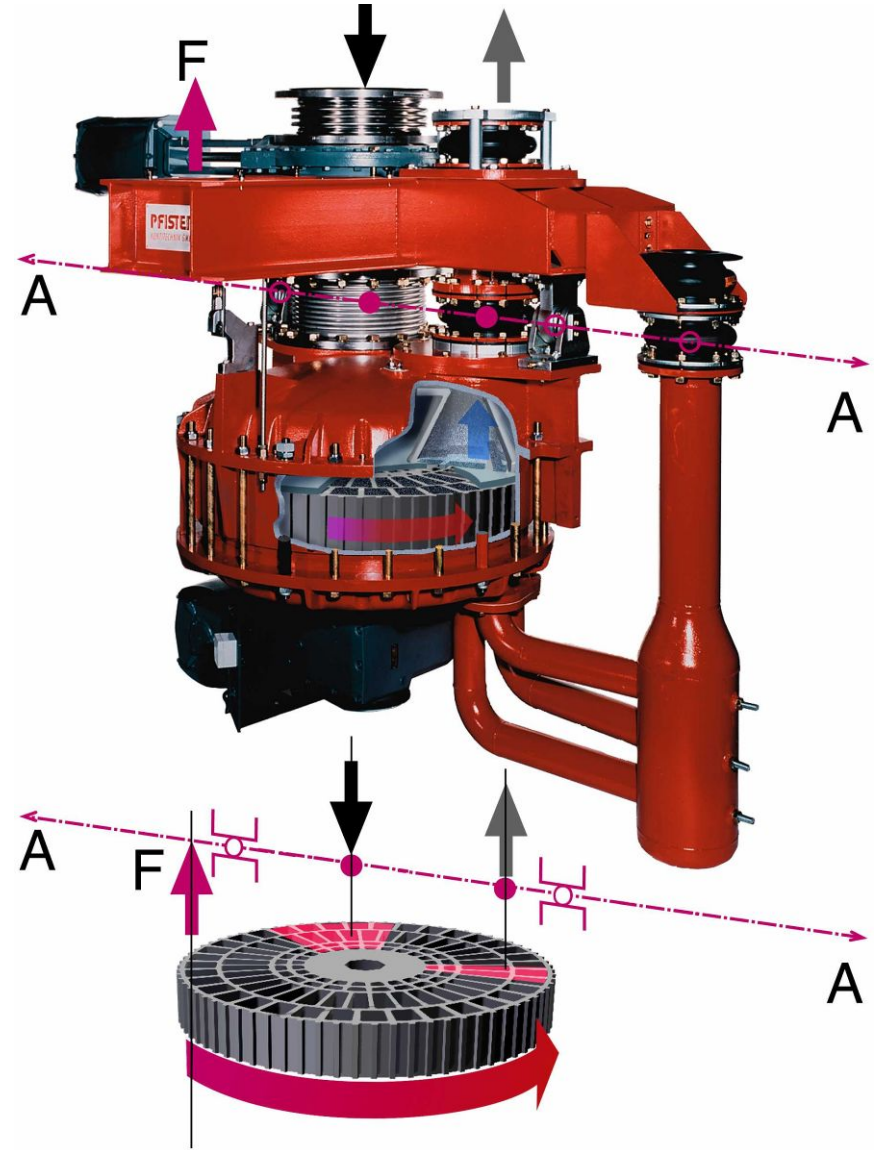
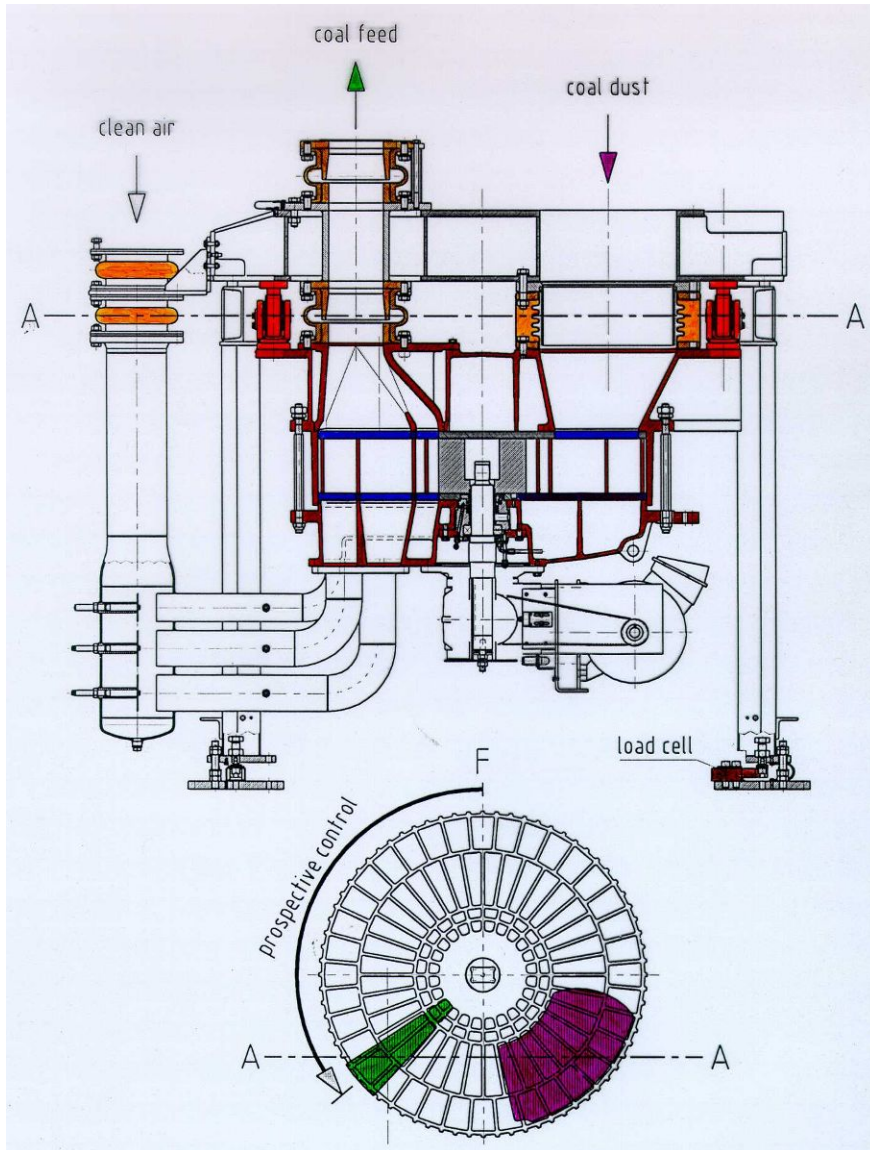

Typical wear - blow out nozzle

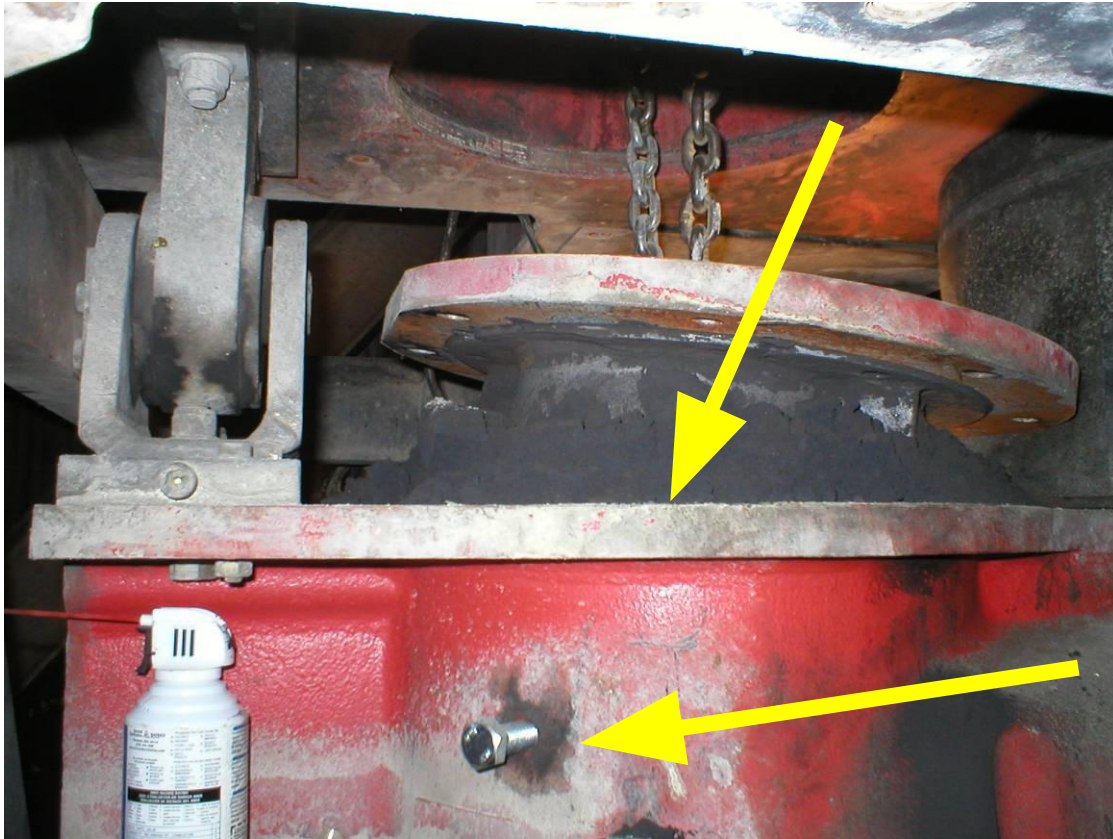

inspection hole, should not be closed by screw or grease

Blow out nozzle here worn out

Typical wear - blow out nozzle



Wear especially coming from the inner chamber air stream



Mostly caused by a wrong adjustment of the flap (air distribution) and gap > 0,3 mm

best adjustment of air speed DRW 3.12/4.12

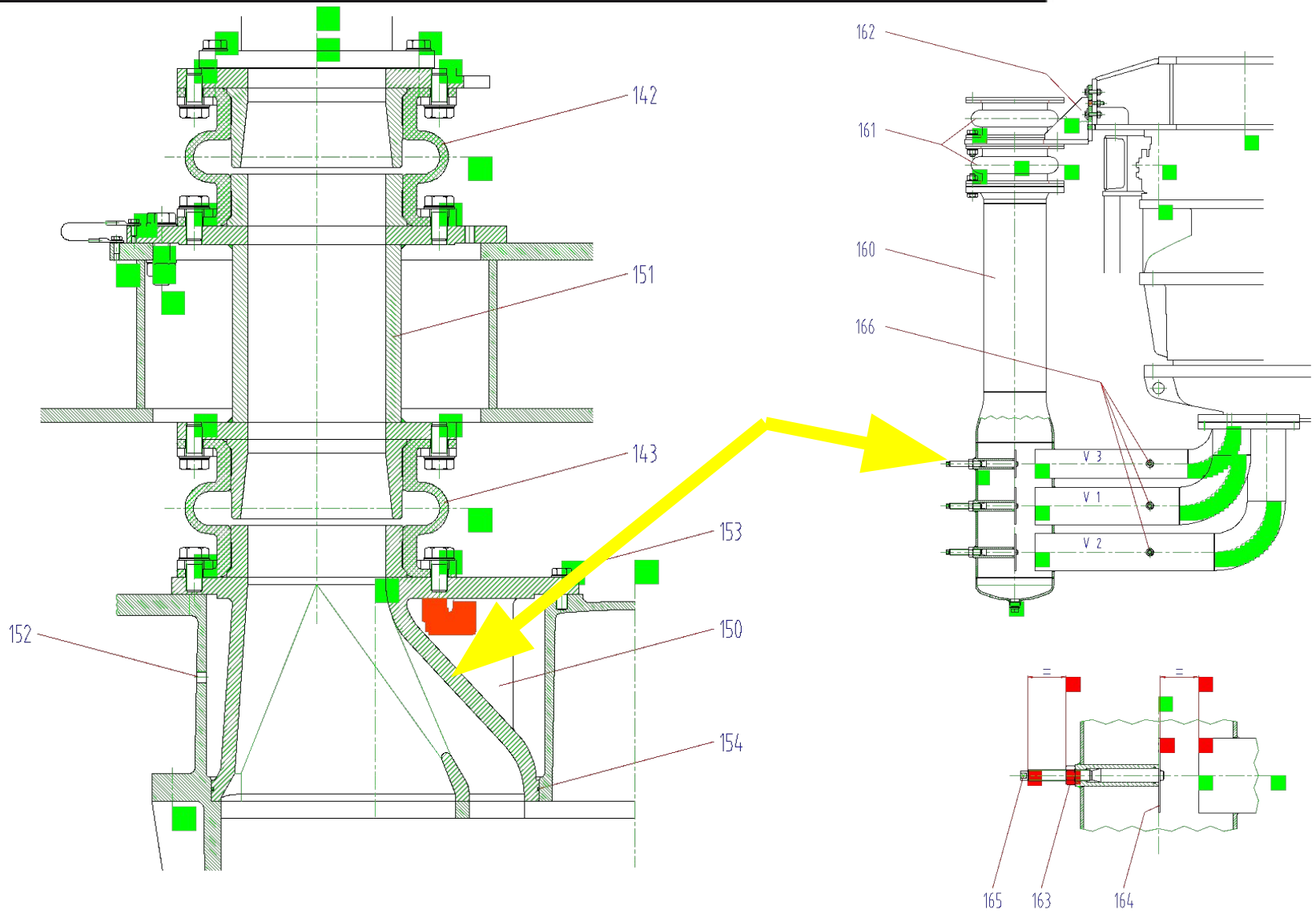

best adjustment of air speed DRW 4.10/12



3 adjusting screws

3 control flaps



Anemometer for air speed measuring

best adjustment of air speed DRW 3.14/4.14

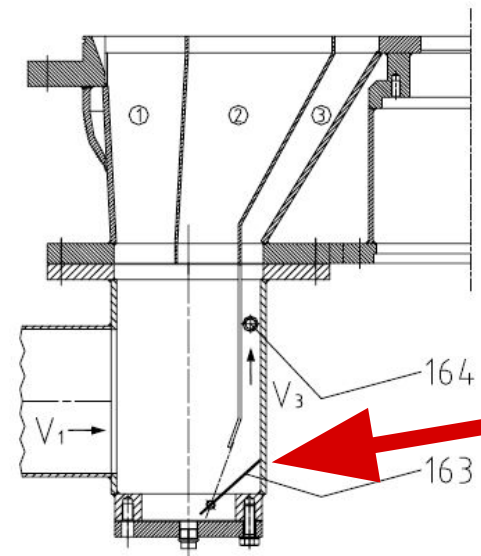
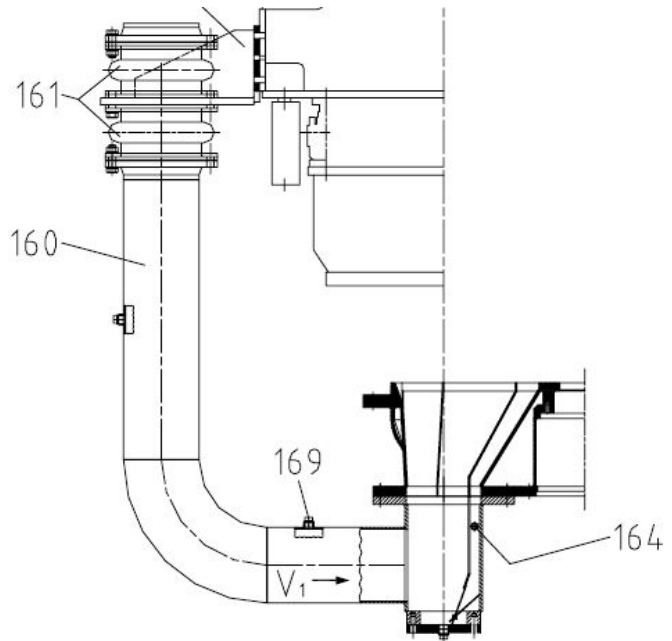

1 control flap

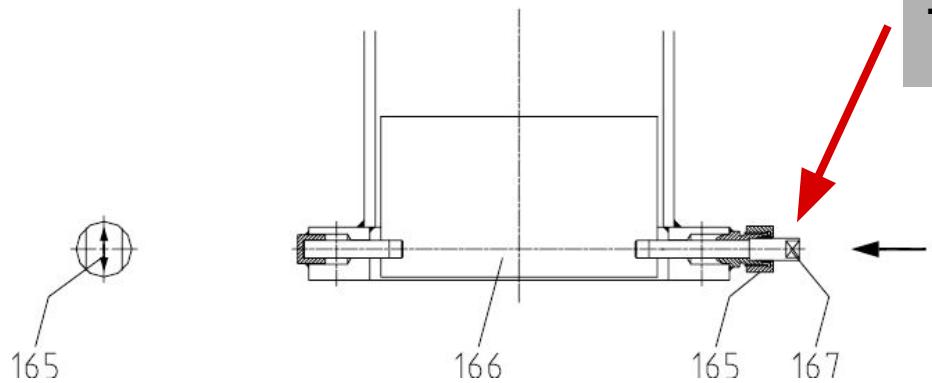

1 adjusting screws

best adjustment of air speed DRW 3.14/4.14

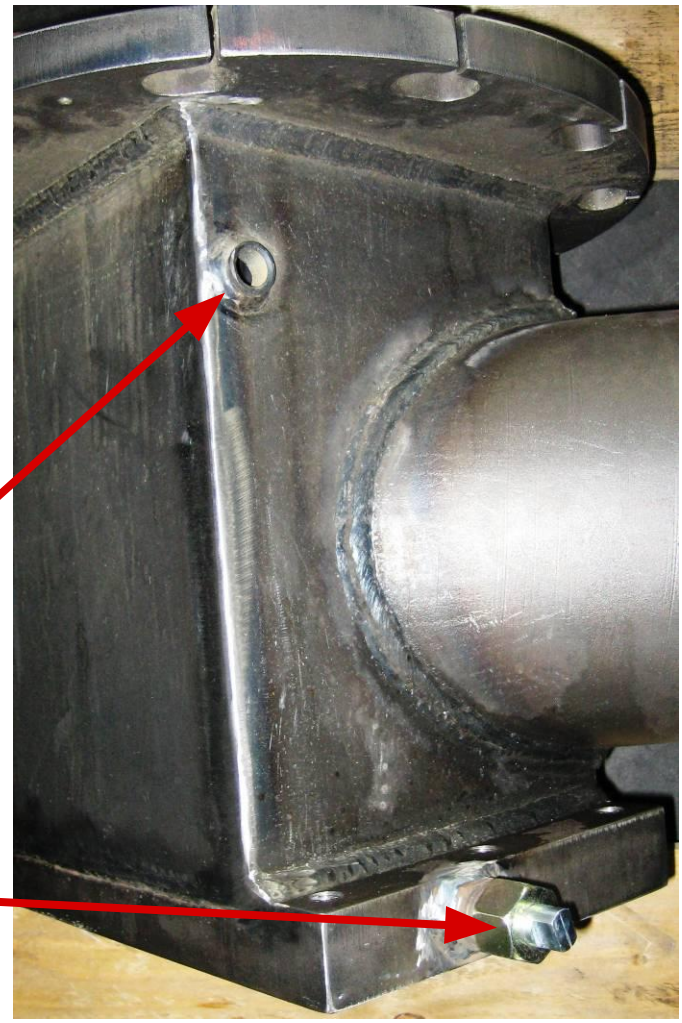
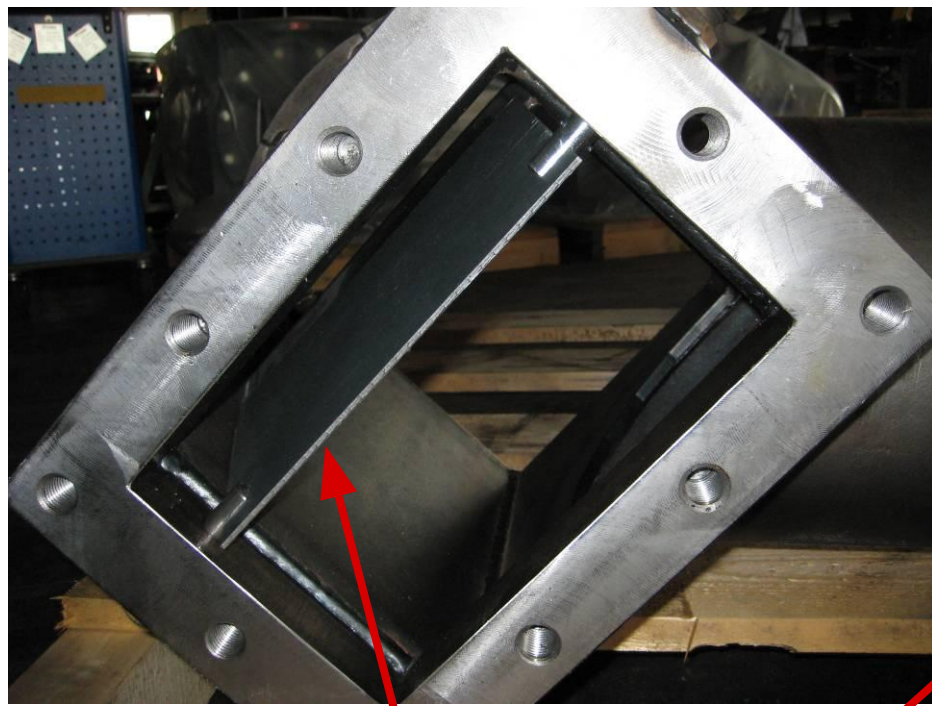

**deflector plate
measuring hole V3
adjusting screw**

air speed standard limit blow out nozzle

Rotor weighfeeder Blow-out nozzle	DRW 4.10 Ø125	DRW 4.10 Ø175	DRW 4.12 Ø200	DRW 4.14 Ø250	DRW 4.14 Ø300
Ratio: v_3/v_1 or v_3/v_2	0.62	0.42	0.34	0.42	0.30
$V_{1\text{std-max.}}; v_{2\text{std-max.}}$ (m/s)	30	60	47	24	33
$V_{3\text{standard max.}}$ (m/s)	18.6	25.2	16	10	10
Blow-out nozzle $v_{\text{nozzle standard max.}}$ (m/s)	40	40	40	25	25

**In case that the standard max speed V
blow out nozzle is exceeded**

**Pfister recommends to install a bypass pipe
including manual operated throttle valve**

bypass solution

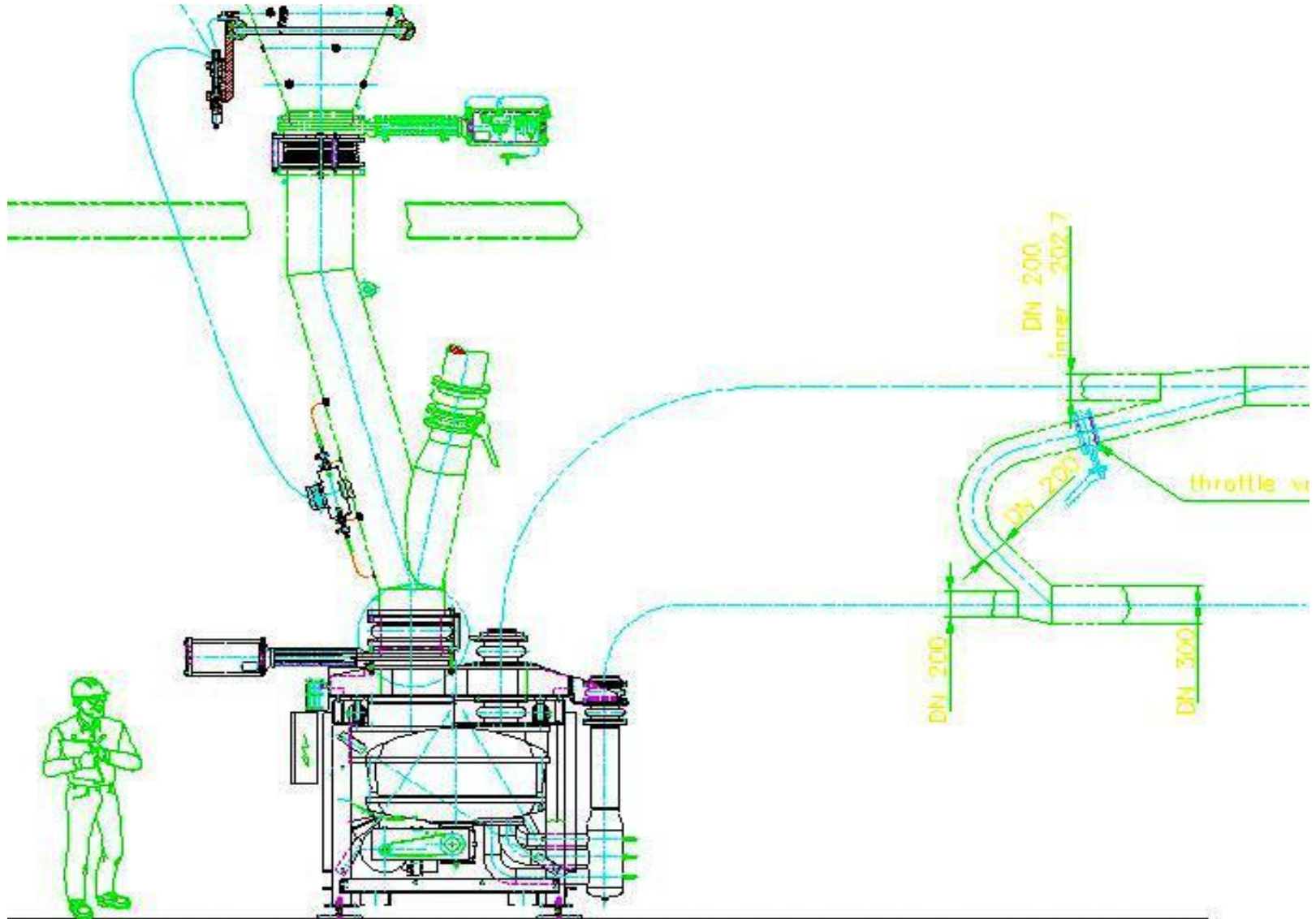

blower and blow pipe design

We offer free of charge to calculate the design of your
blower capacity and blow pipe diameter

We need:

**Horizontal length
Vertical length
No. of elbows (bents)
Max. requested feedrate**

We offer free of charge to recalculate your existing
**blower capacity and blow pipe diameter
design**

We need:

**Horizontal length
Vertical length
No. of elbows (bents)
Max. requested feedrate**

Existing inner diameter of blow pipe and existing blower capacity

WEAR part – Blow out nozzle and flexible joints

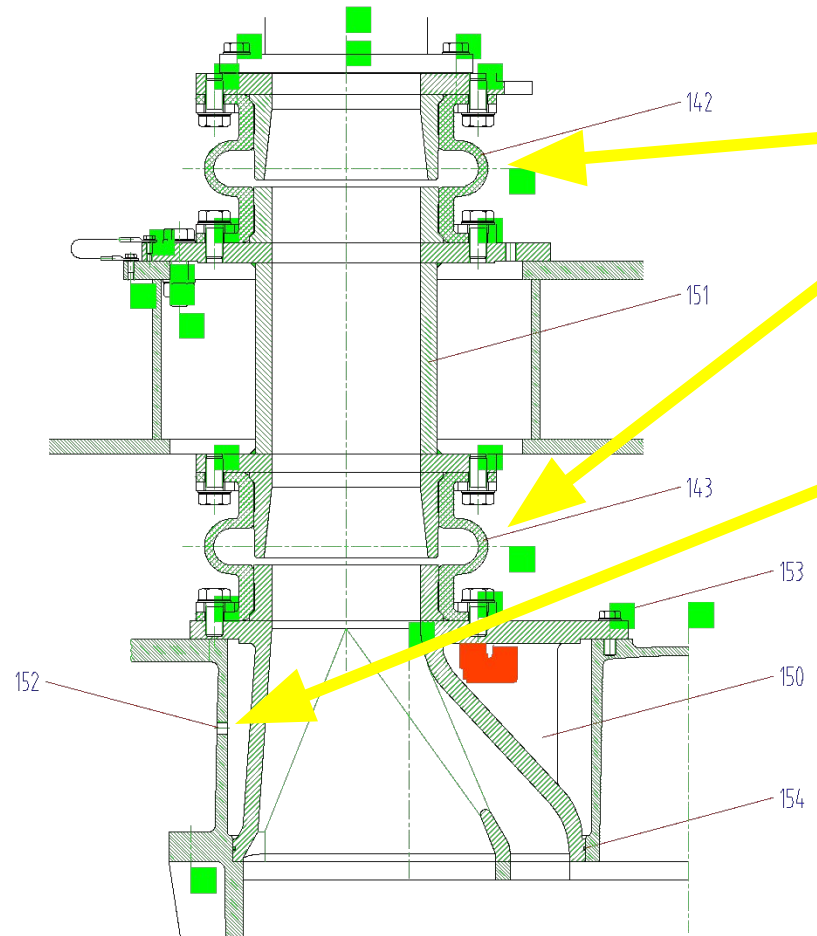

blow out flexible joint with wear protection (ceramic liner)

inspection hole blow out nozzle for condition check

smaller holes can be welded

after replacement or disassembling pivot must be done

Maintenance PIVOT

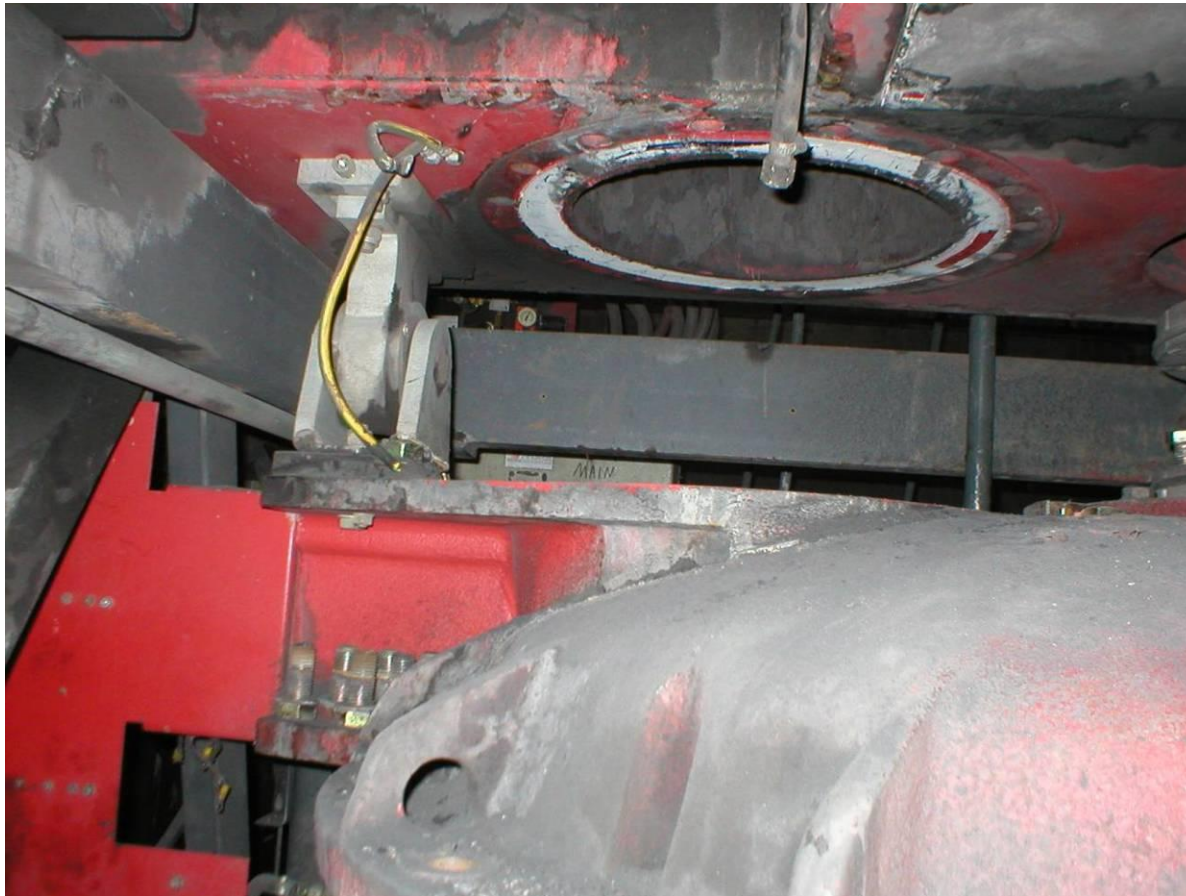

Replacing the inlet compensator means adjusting the pivot (symmetry) newly refer to 550.096.60.04 IS Repair Instructions chapter 8

WEAR part – Blow out nozzle and flexible joints



**flexible joints cure
replacement requested at least
after 5-7 years operation**

**wear protection
to be checked at each
rework or replacement of
plates/wheel**

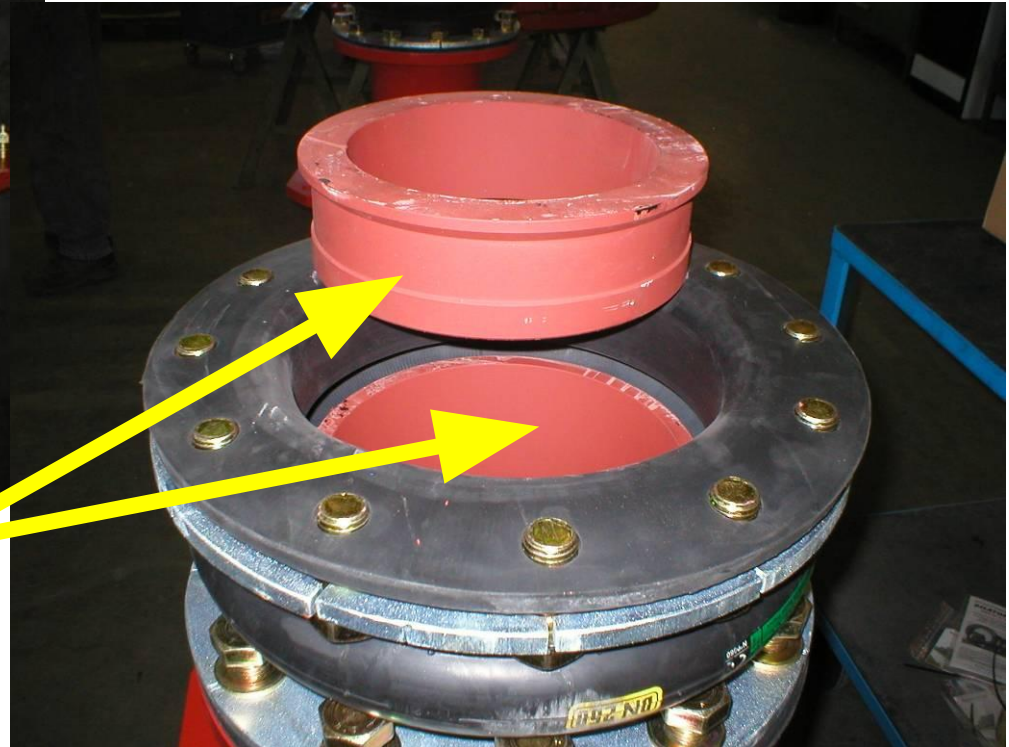

Maintenance on electrical parts



□ Drive Belt

case: correct adjustment

Drive Belt Adjustment

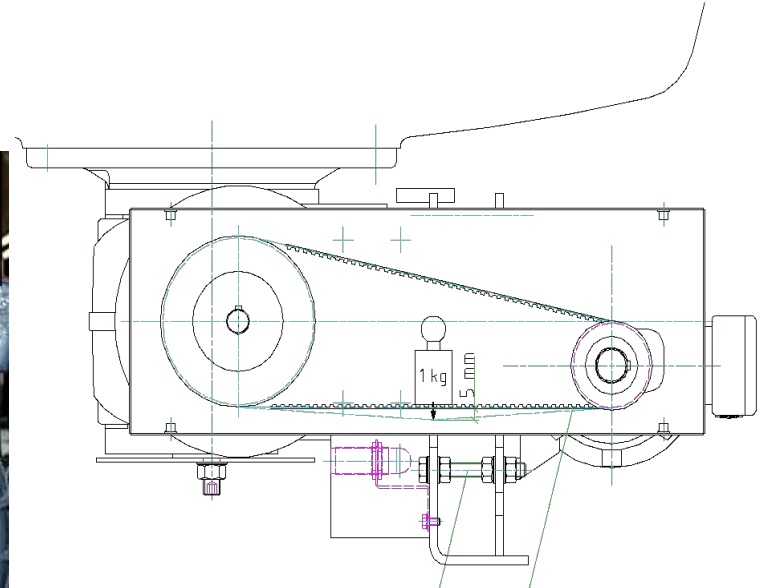
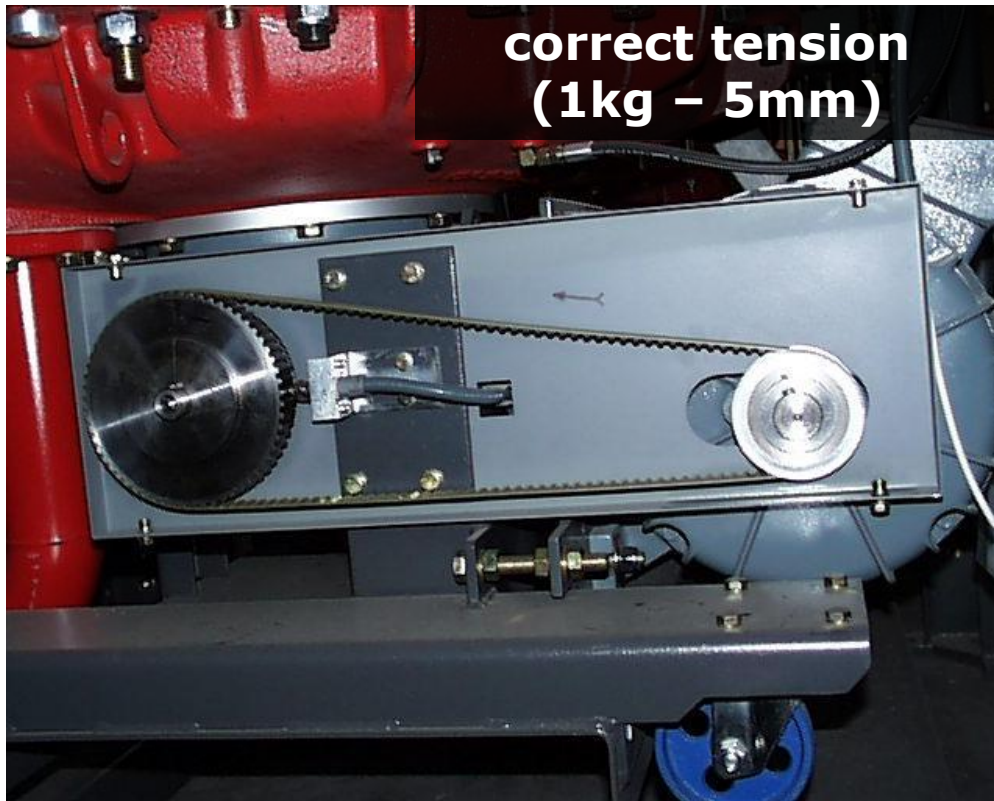

**toothed wheel (pinion)
fitting to drive belt**

**drive belt according ATEX
with correct
no. of tooth's and length**

**Correct adjusted tension important for lifetime and measuring results
beneath the load cell signal is speed the second important measuring value**

Drive Belt Adjustment

REASON?

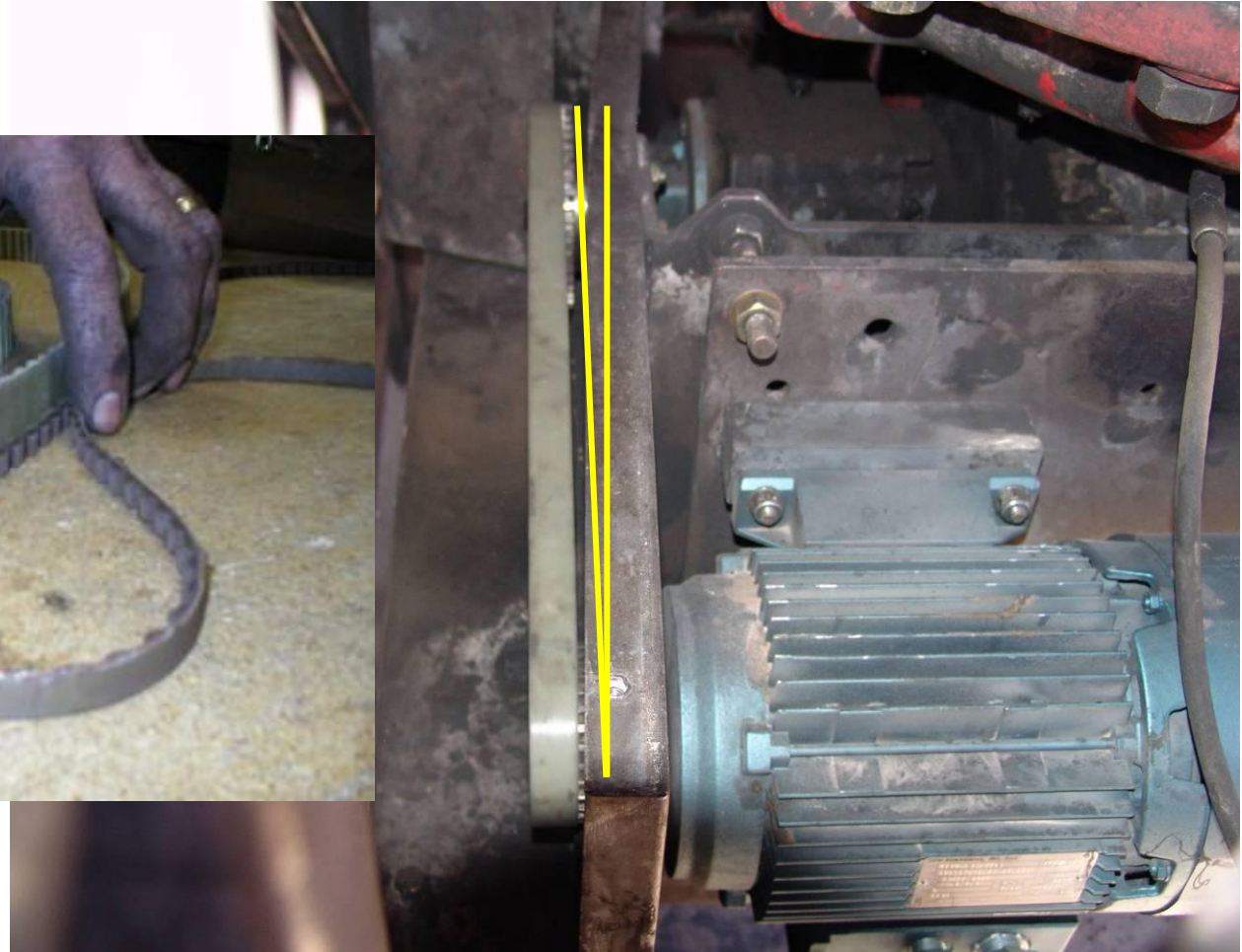

**Attention, old drive belt
NON ATEX**

Correct alignment saves the drive belt from high wear and reduced lifetime

Drive Belt Adjustment



Correct drive belt tension, condition of the pinions

Over tension causes high wear at the drive belt ground and increased wear at the pinions

=> this can lead to a fast rupture of the drive belt (possible after days of operation)

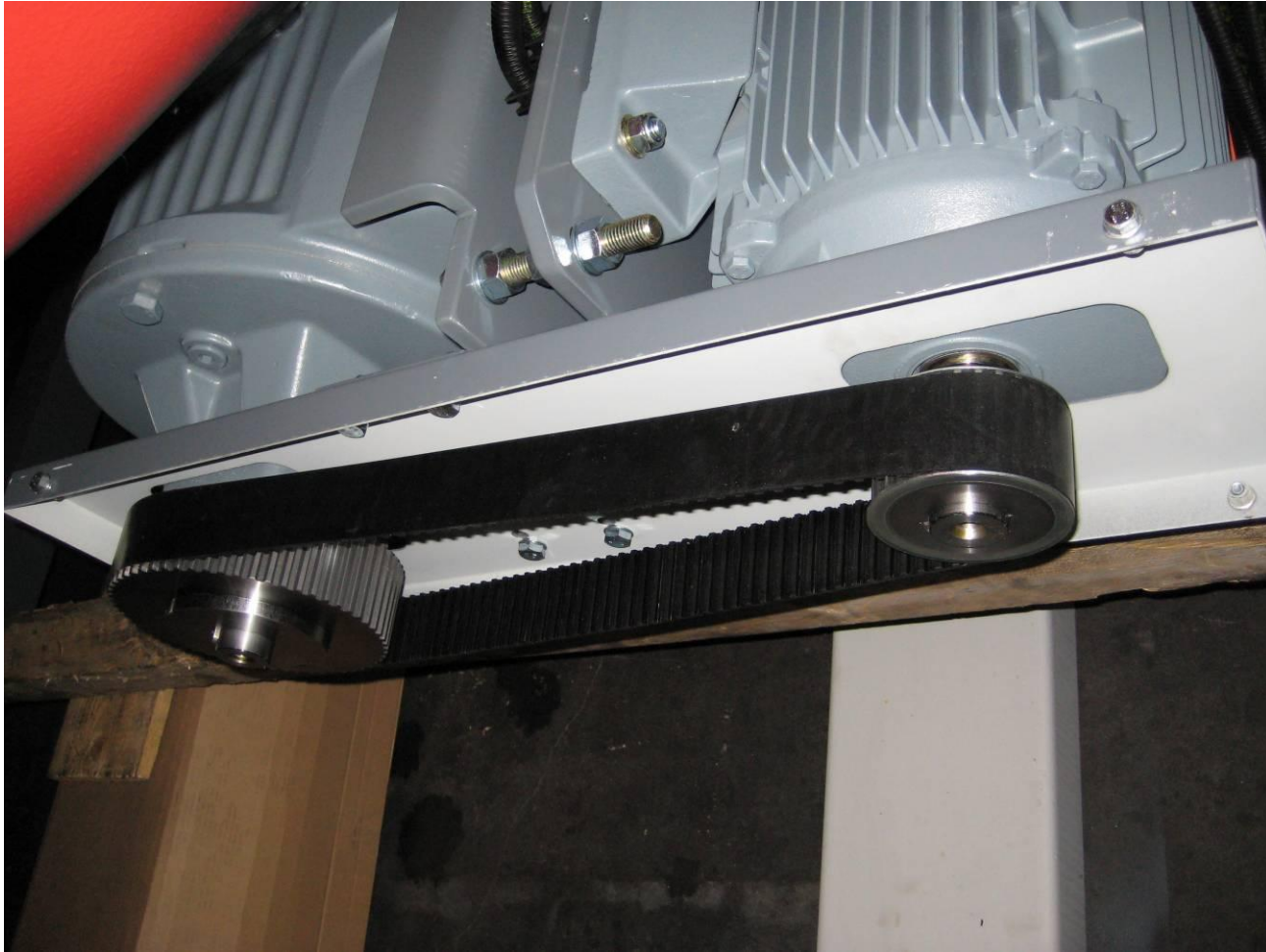

**New drive belt for DRW 4.14 acc. ATEX (conductive)
only in black color available**

□ Wear rating

**case: condition of sealing plates
and cellular wheel**

Mechanical Maintenance机械维护

Maintenance theory维护原理 – wear parts磨损部件

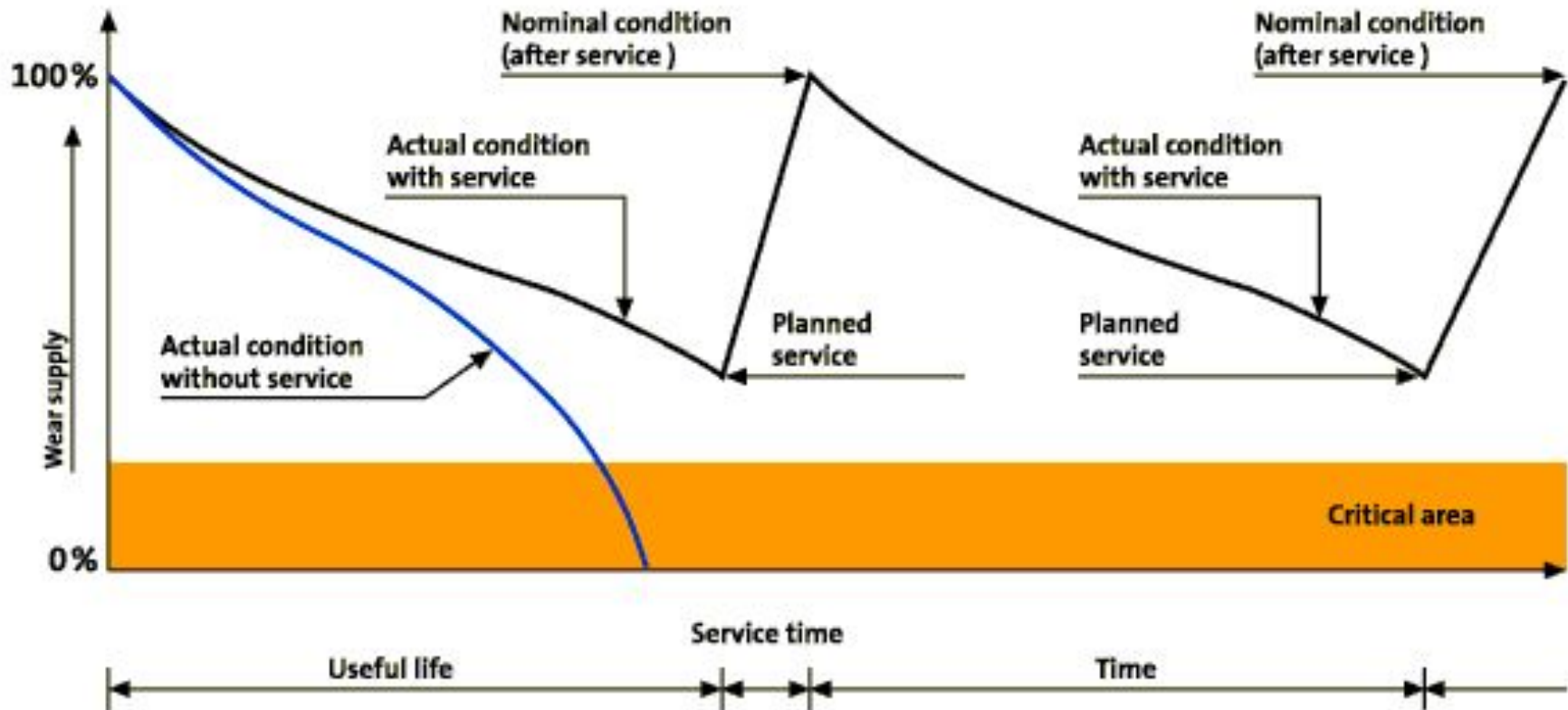

Run of the wear supply with and without maintenance (referring to maintenance, inspection and service)

Mechanical Maintenance机械维护

EXAMPLE Pfister Coal Dosing Feeder DRW以煤粉称为例

Principal wear parts主要磨损部件

- sealing plates and rotor wheel密封板和转子
- blow out nozzle出料头
- flexible joints and accessory wear protection
软连接及其耐磨保护附件
- drive belt齿形皮带
- sinter plates for aeration unit助流单元的粉末冶金膜片

Lifetime depends mainly on使用寿命主要取决于:

1. **Material characteristics: abrasive, grain size, temperature etc.**
物料(煤粉)的特性: 研磨性, 颗粒大小, 温度等。
2. **Pneumatic characteristics: airspeed, air distribution and backpressure.**
(煤粉输送)气体的特性: 风速, 空气的扰动和反压。
3. **Periodic maintenance: lubrication, gap adjustment, etc.**
定期的维护: 润滑, 间隙的调整等等。

机械维护-基于状态的

Condition based maintenance is not that easy, because the condition to be judged

基于状态的维护不是一件容易是事, 因为要对(设备运行)状态作出准确的判断

Who can rate谁能评估 – what's needed需要什么 ?

- ✓ measuring values for allowed tolerances检测允许的公差
- ✓ standard or average lifetime标准或平均使用寿命
- ✓ knowledge about factors influencing lifetime/condition
关于影响使用寿命/状态因素的知识
- ✓ monitoring of the error rate - related to specific components
错误的监控, 判断与之相关的部件
- ✓ experience about influencing operational factors
影响操作因素方面的经验

specifications, observations + experience is needed
as precondition for rating!

Mechanical Maintenance – Repair Instructions

REPAIR-INSTRUCTIONS		PFISTER
<u>Rotor-Weighfeeder-DRW-4.10/4.12/4.14</u>		
TRM-/24.09.2003		550.096.60.04-IS-a-GB

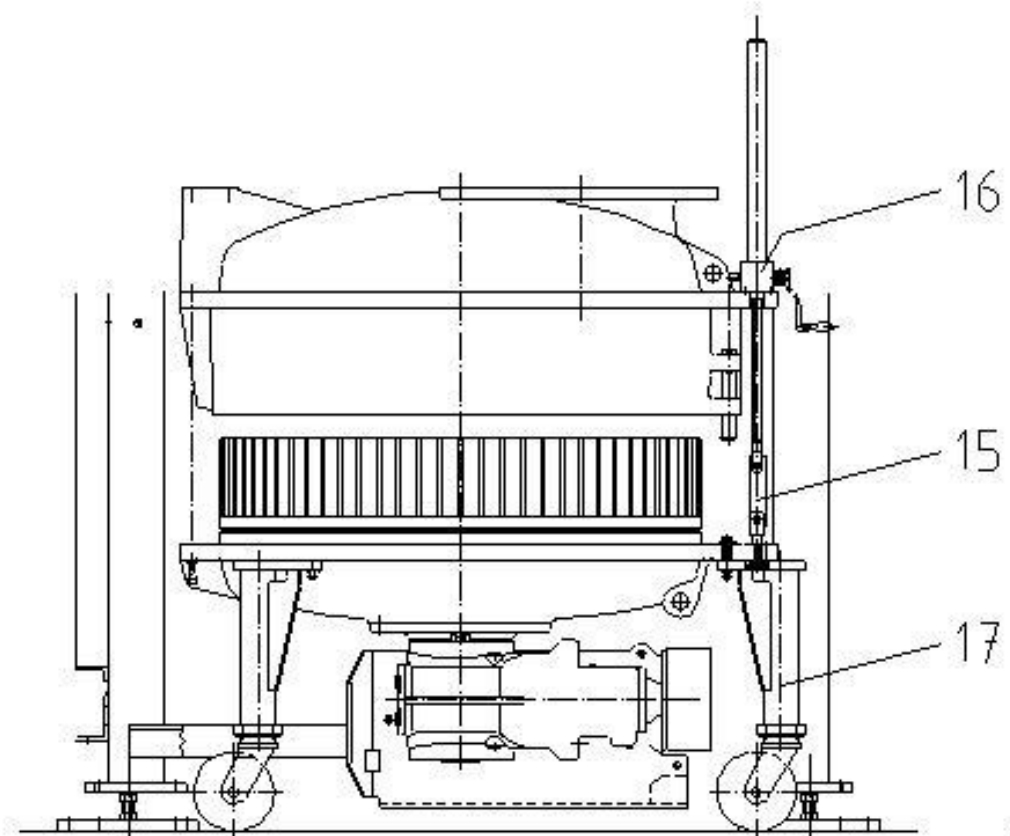

定期维护-基于状态的

Allowed tolerances for DRW sealing plates and rotor wheel
密封板和转子的允许公差参见维修手册 refer to repair instructions

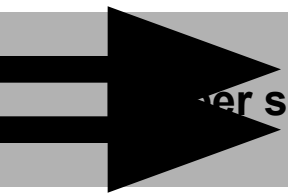
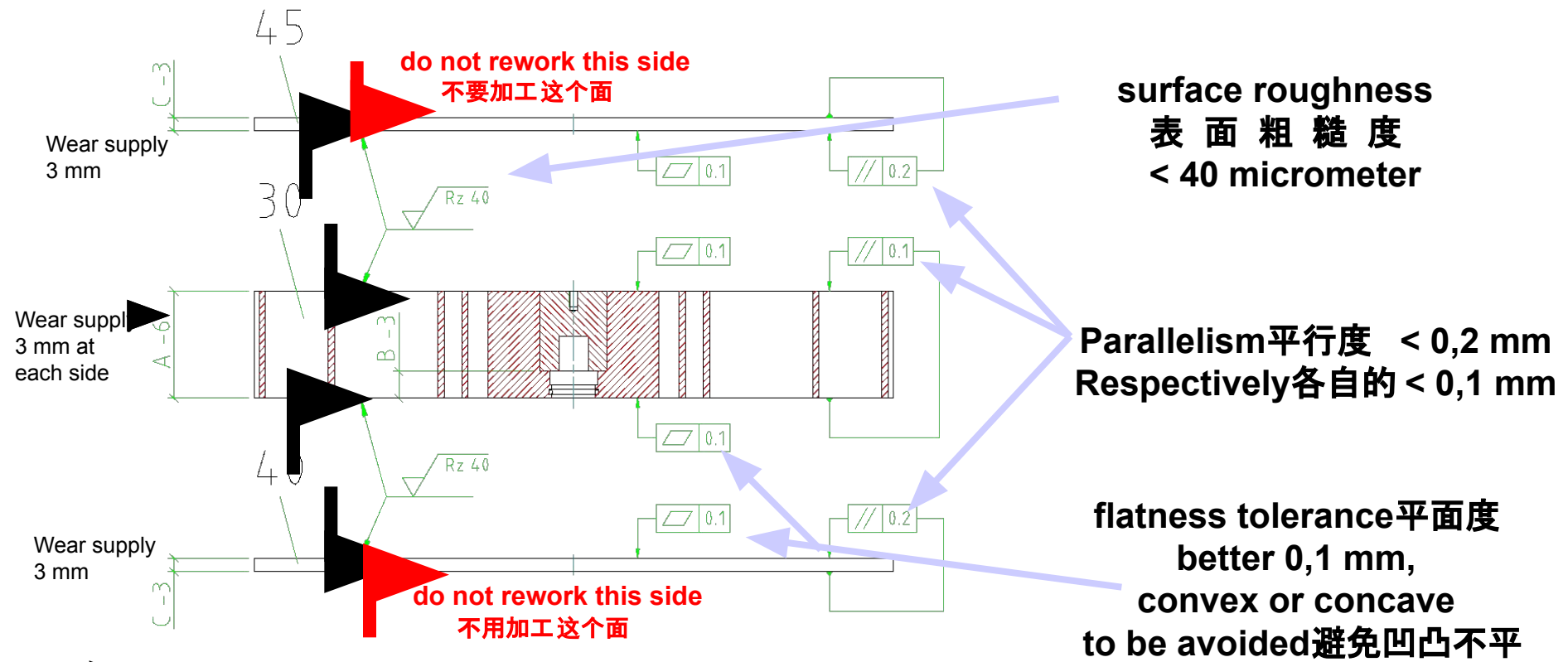

recommendation to machine always the 4 sides 推荐只加工4个面
upper side of the lower plate, lower side of the upper plate both sides of the wheel
上密封板的下面, 下密封板的上面, 转子的两面

WEAR part – rotor wheel

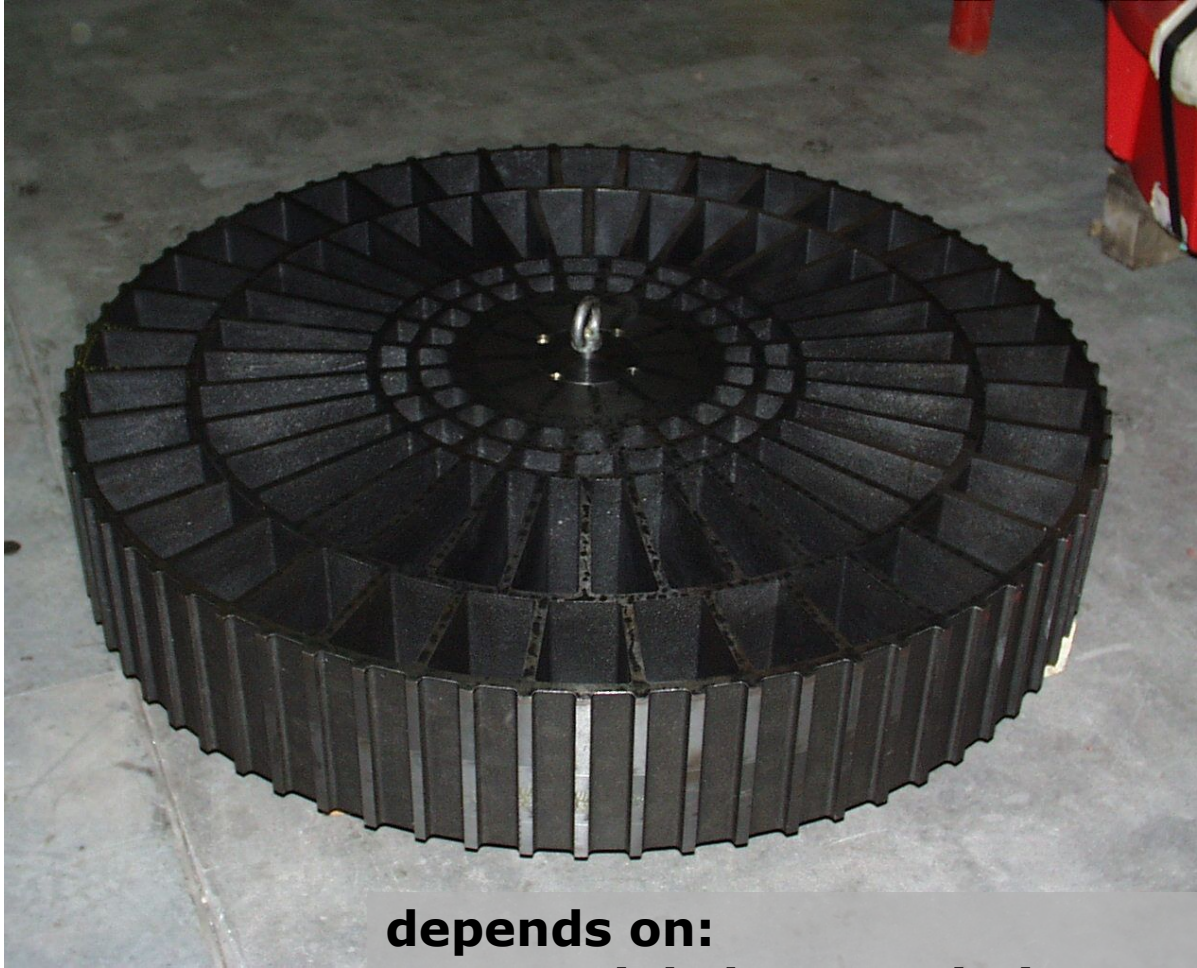

depends on:

- 1. material characteristics**
- 2. foreign particles in the coal**

**Standard lifetime
approx. 2-3 years**

**Rework
or
Replacement**

WEAR parts – lower and upper sealing plate

**high accuracy parts
for correct gap adjustment**

ruler and feeler gauge

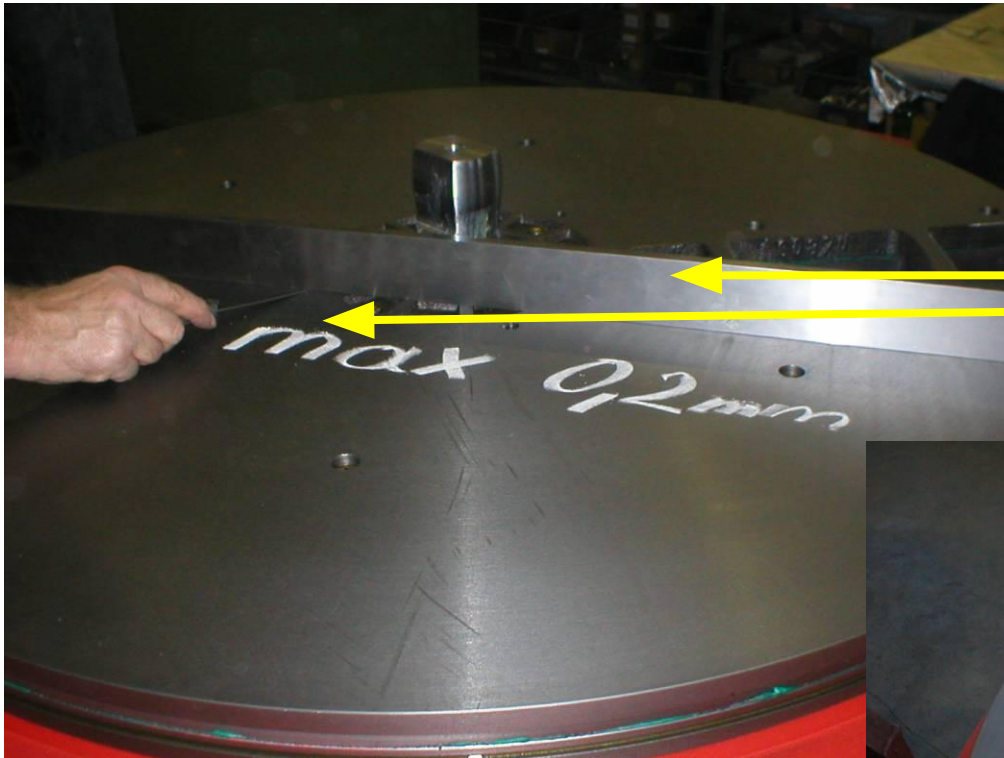

**correct gap adjustment
for
reliable accuracy
and minimized wear**

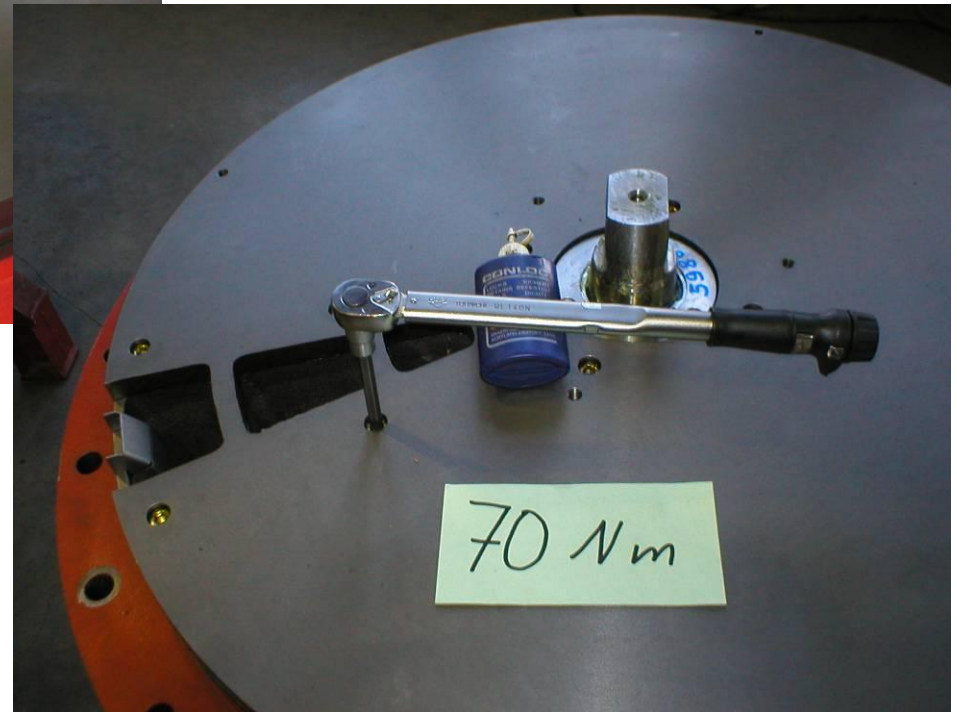

Quality of reworked wear parts



Quality of reworked sealing plates and cellular wheel should be verified as well in the pockets

Wear rating

Replace - rework - other action for DRW sealing plate?

optical impression like a disc record (LP), sealing plate can be used for further kiln period

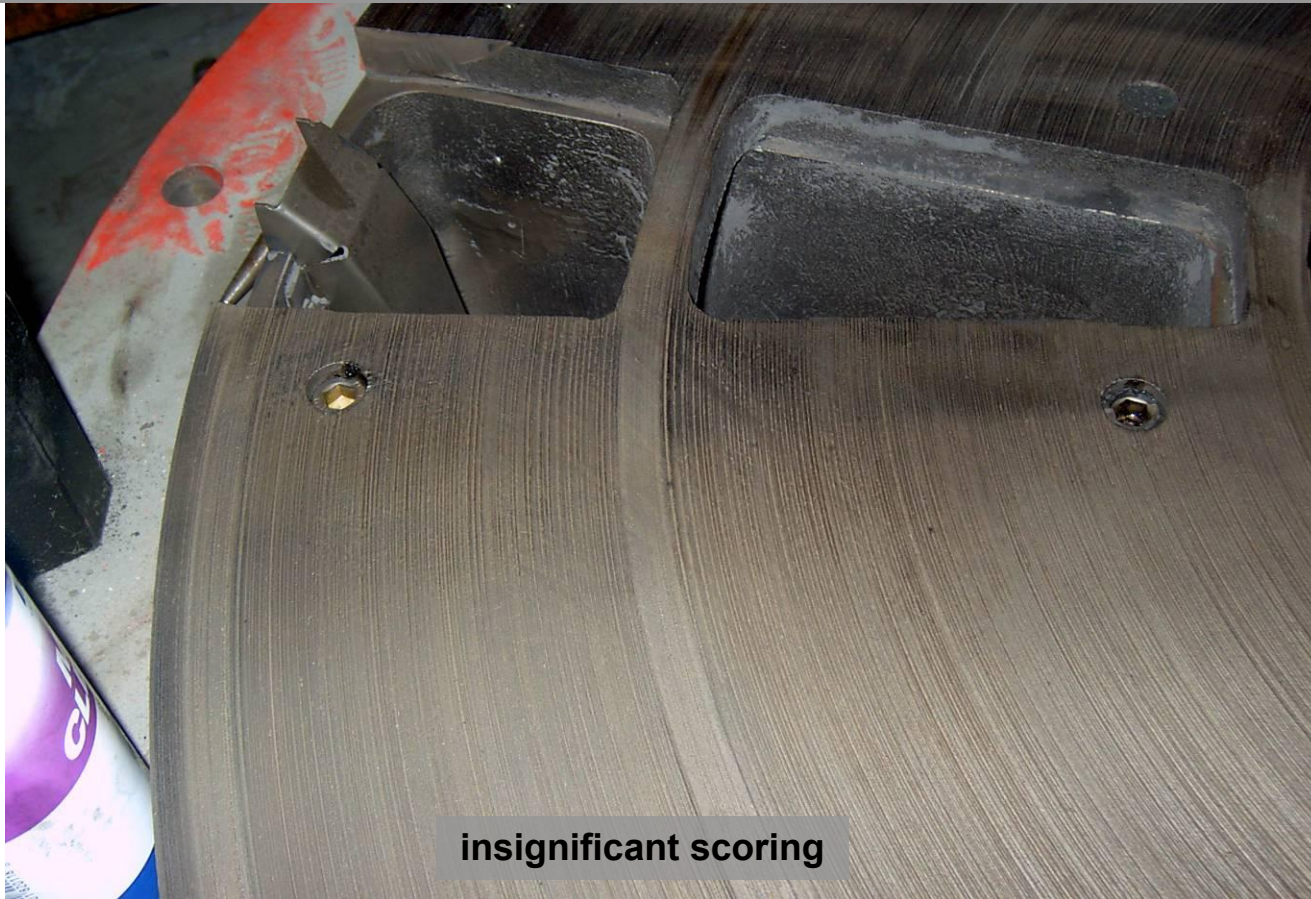

Wear rating

Replace - rework - other action for DRW lower sealing plate?

allowed tolerances exceeded
rework (if thickness sufficient) or replacement highly recommended

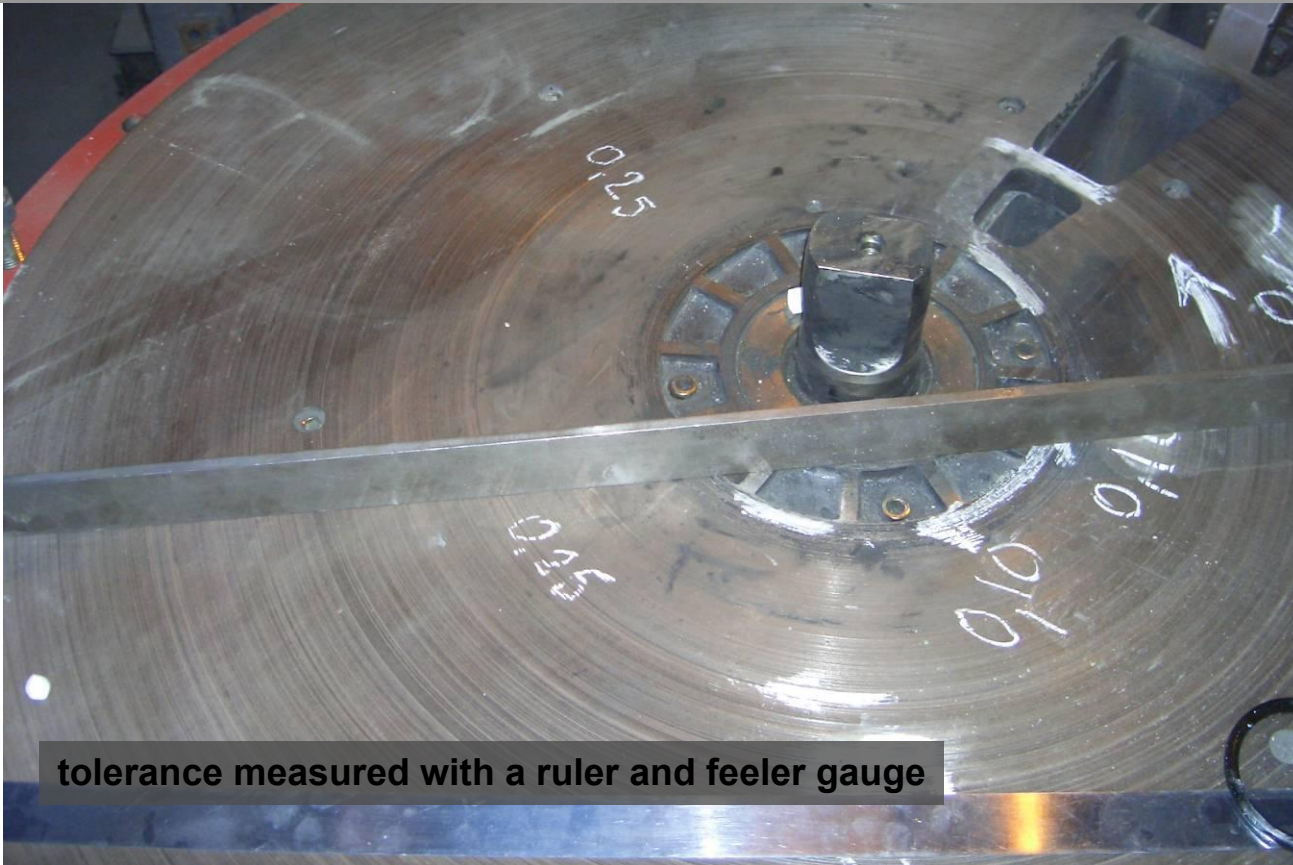

tolerance measured with a ruler and feeler gauge

Wear rating

Replace - rework - other action for DRW rotor wheel?

measuring difficult, optical impression decisive
rework (if thickness sufficient) or replacement recommended

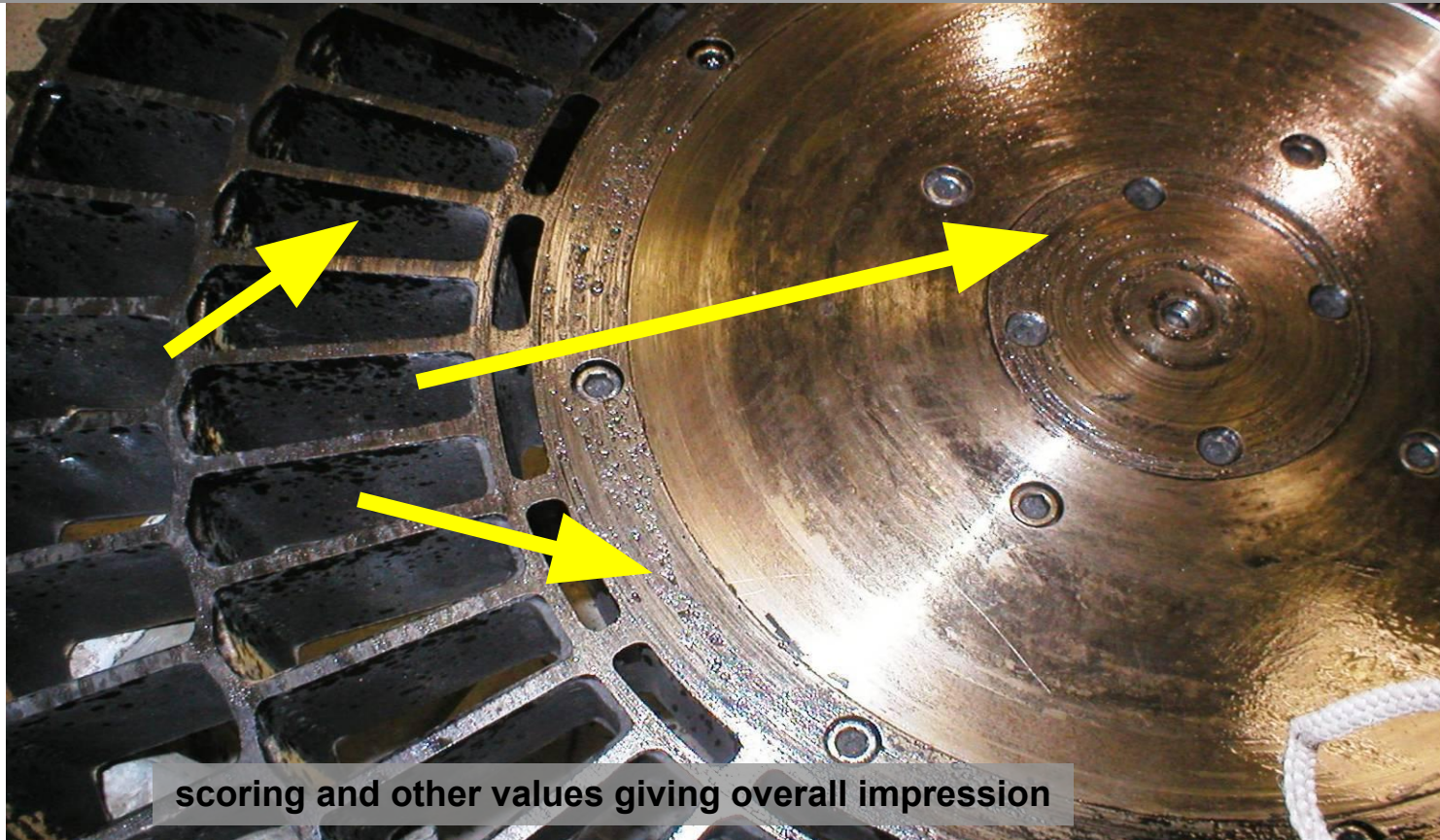

Wear rating

Replace - rework - other action for DRW sealing plate?

measuring difficult, optical impression decisive
rework (if thickness sufficient) or replacement highly recommended

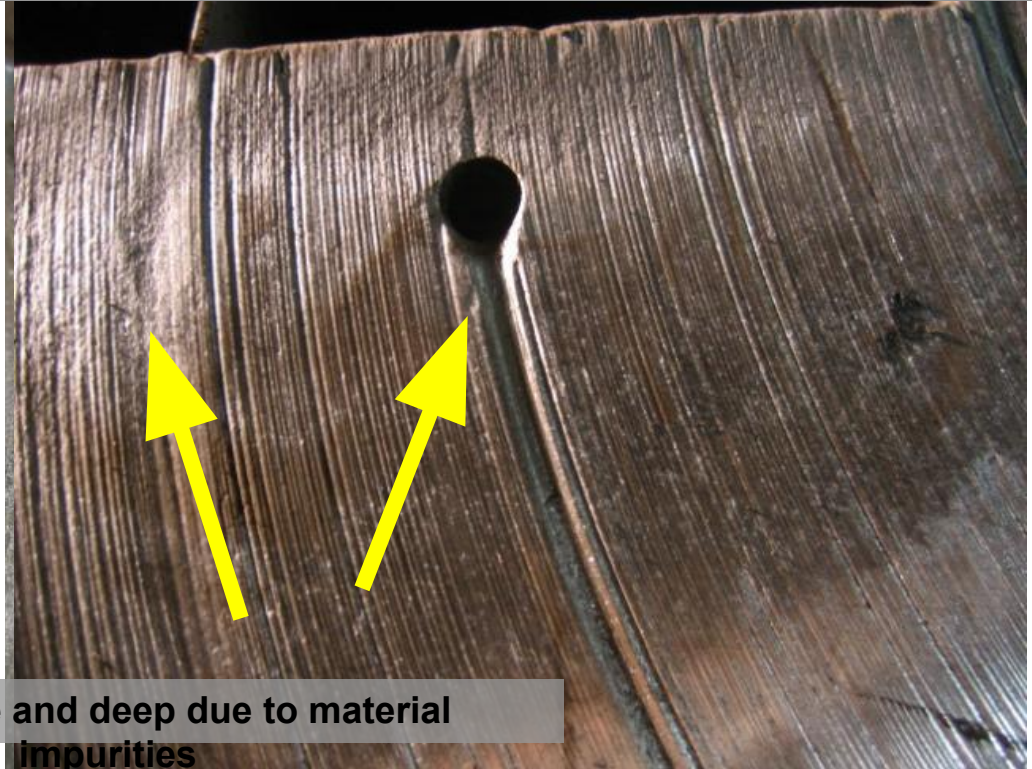

grooves wide and deep due to material impurities

Wear rating

Replace - rework - other action for DRW sealing plate?

measuring the wash out section with ruler and feeler gauge
rework (if thickness sufficient) or replacement highly recommended



caused by a fatal open gap of approx.
1mm

air stream directly from inlet to outlet

Replace - rework - other action for DRW sealing plate?

immediate replacement highly recommended



**caused by a fatal open gap of some mm
air stream directly from inlet to outlet incl. high back pressure and high airspeed**

Wear rating

Replace - rework - other action for DRW sealing plate?

immediate replacement highly recommended



**caused by a fatal open gap of some mm
air stream directly from inlet to outlet incl. high back pressure and high airspeed**

Preventive Maintenance - condition based

Allowed tolerances for DRW sealing plates and rotor wheel
refer to repair instructions

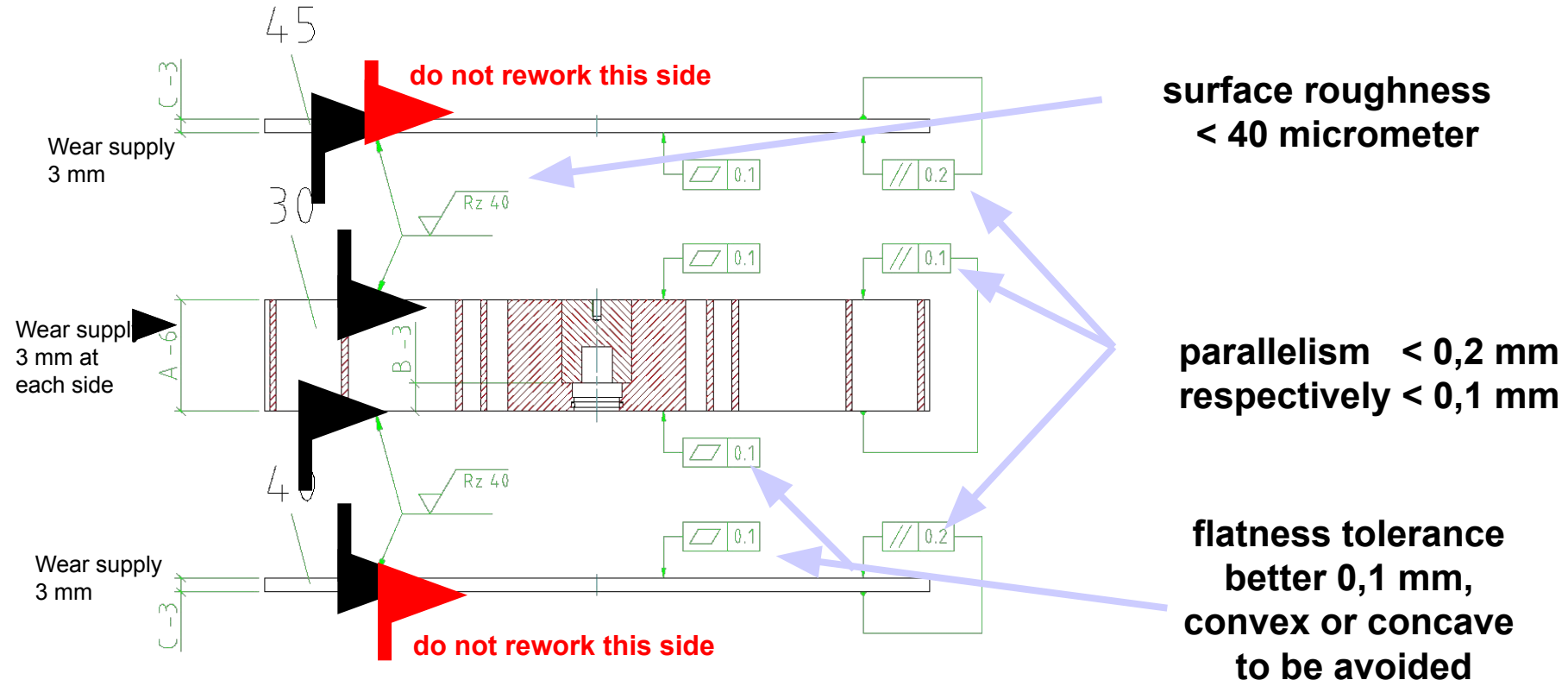

recommendation to machine always the 4 sides
side of the lower plate, lower side of the upper plate both sides of the wheel

Professional Rework



Our team at Pfister Qingdao offers a professional rework of sealing plates and cellular wheel and guaranties

to keep even the closest tolerances

**Rework certificate
incl. actual measuring values**

Hologram identification tag

We take care of your wear!



Professional rework
of your feeder wear parts



Most important documents



**Maintenance instructions
550.096.60.04. WA**

**Repair instructions
550.096.60.04. IS**



Thank you for your attention

Pfister GmbH