

CLOCK

Sephiroth Kwon

GRMA

20-05-2009

OUTLINE

- **Clock Distribution Diagram**
- **Signal Description**
- **Repair Flow Chart**
- **Repair Technique**

CLOCK Distribution Diagram

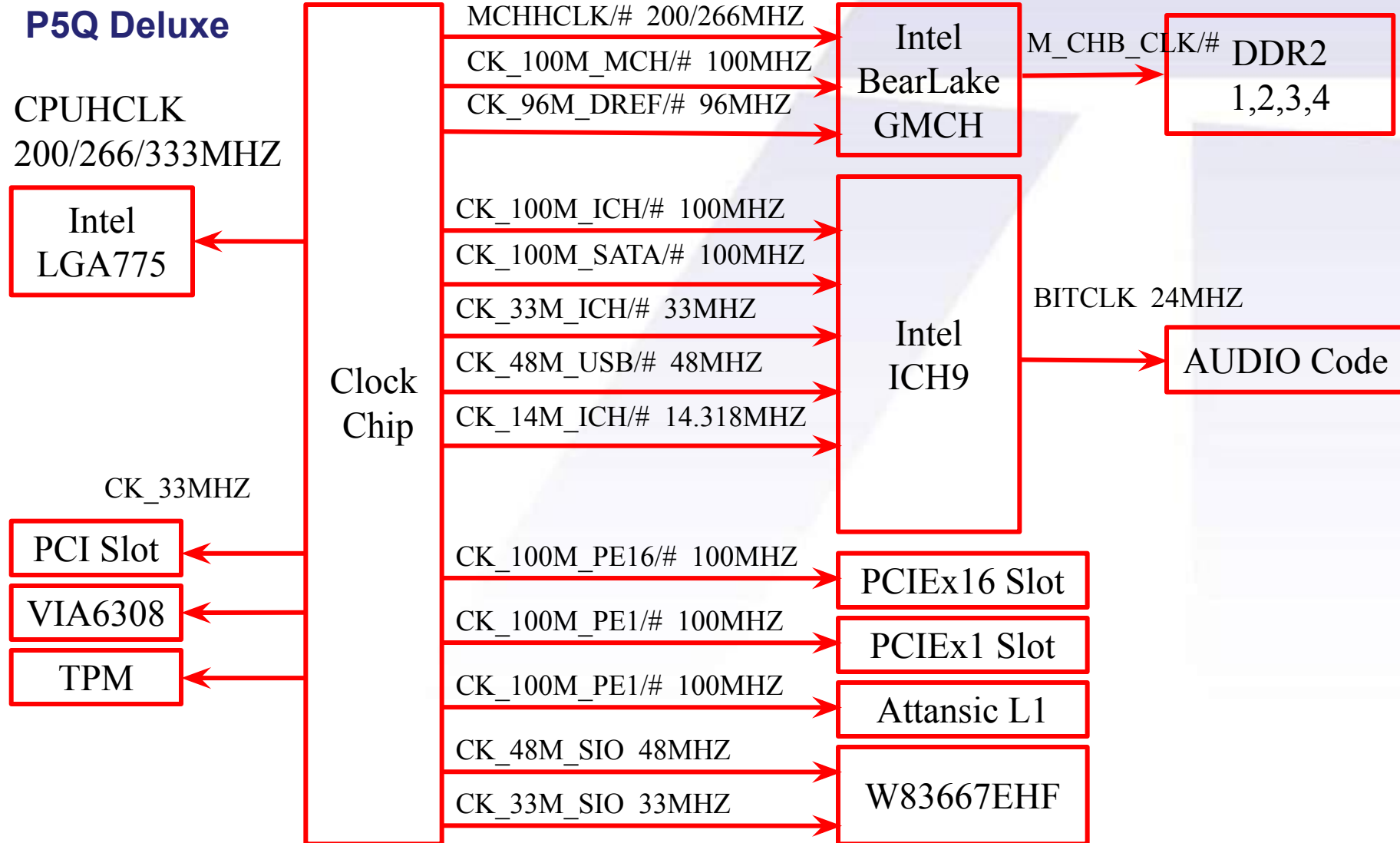

CLOCK Distribution Diagram

M4N78 AM

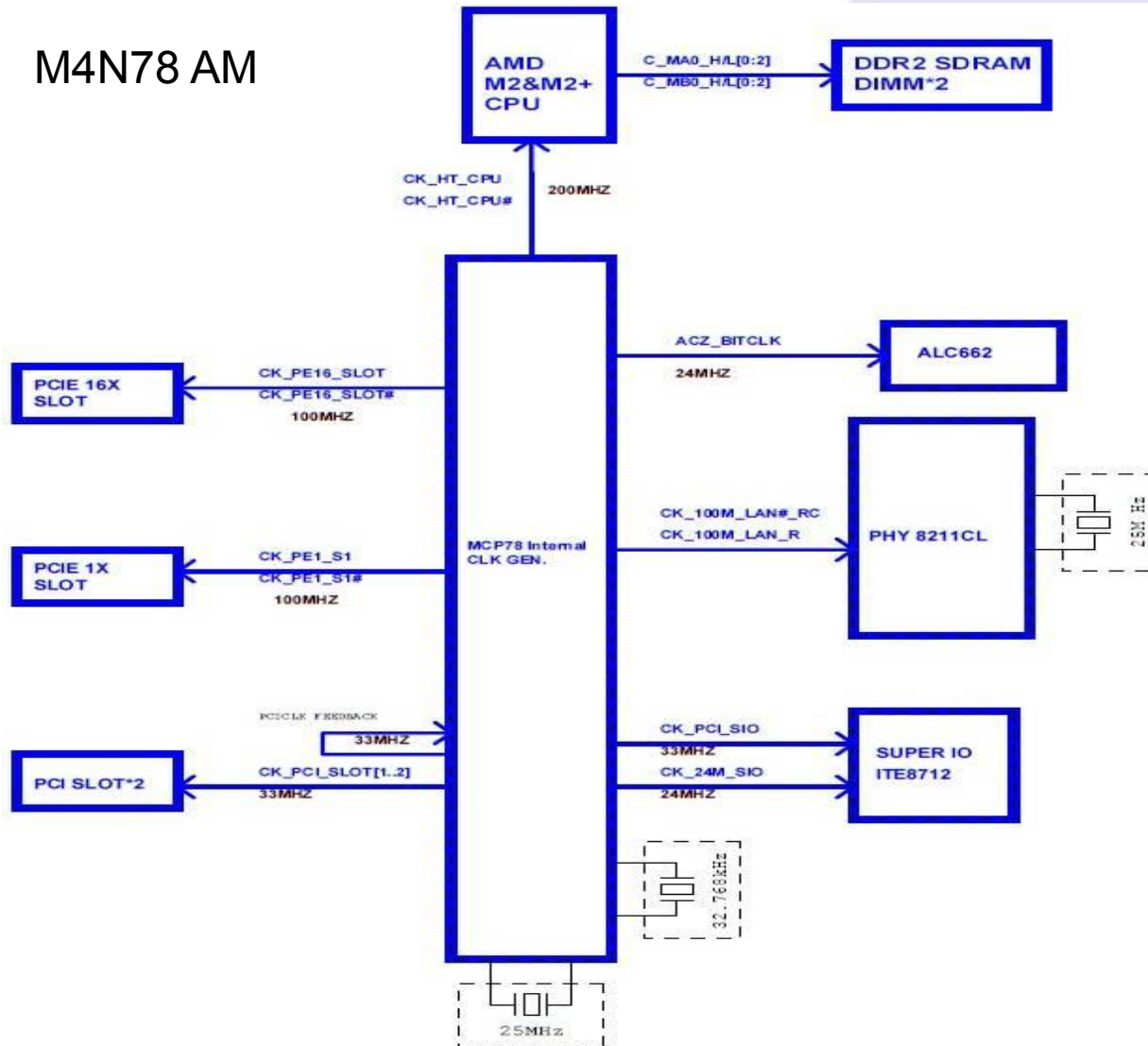

CLOCK Distribution Diagram

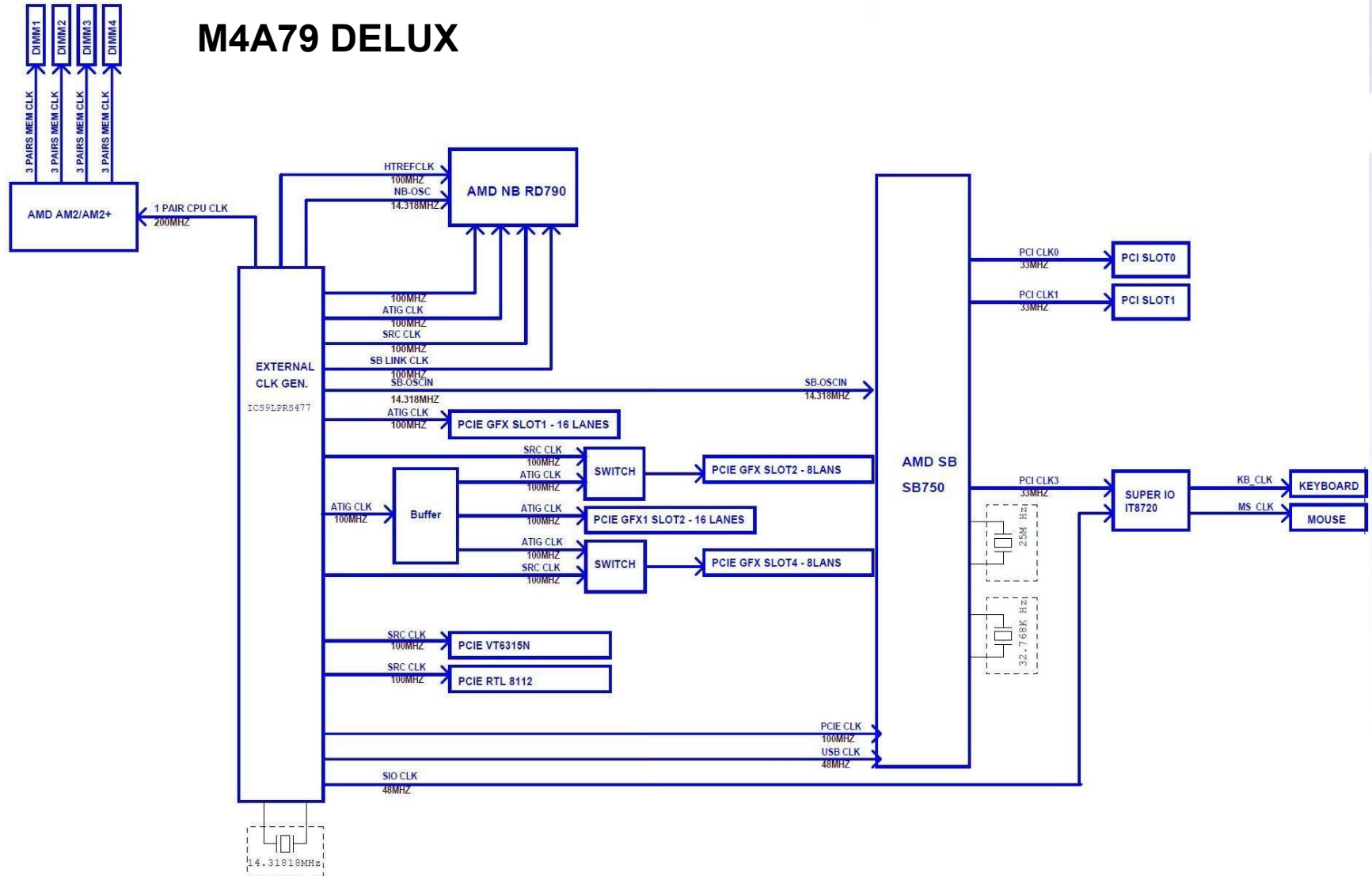

Signal Description

1. Sometimes the Clock chip connect one Diode or BJT component. It depends on designer.

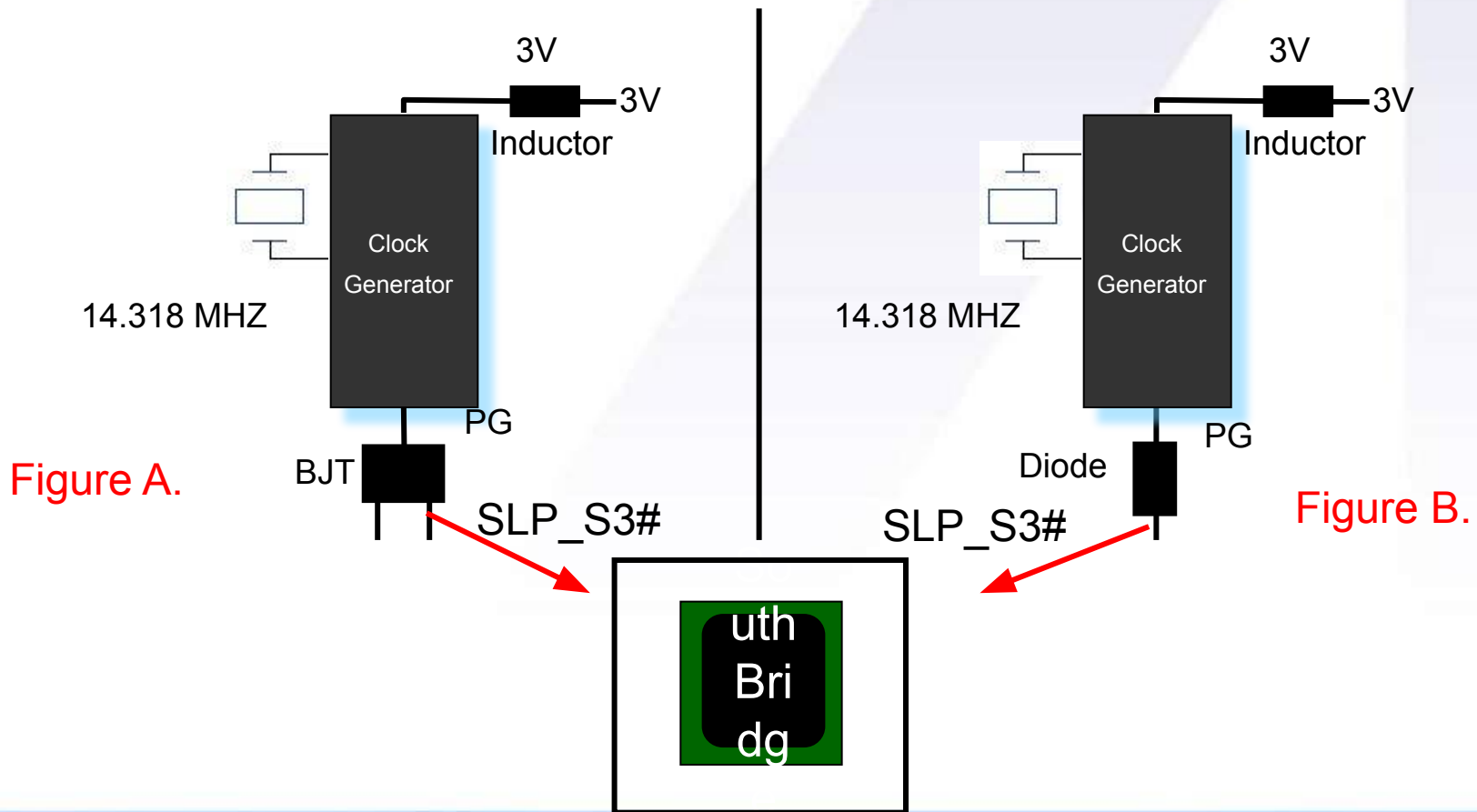

Signal Description

- Sometimes we can find BAT54AW near ICS.
- VRMPWRGD and SLP_S3# must be 3V
- Finally, CLKVCC offer 3V PWRGD to Clock Generator
-
- If Clock Generator doesn't work, you must measure this PWRGD signal first.

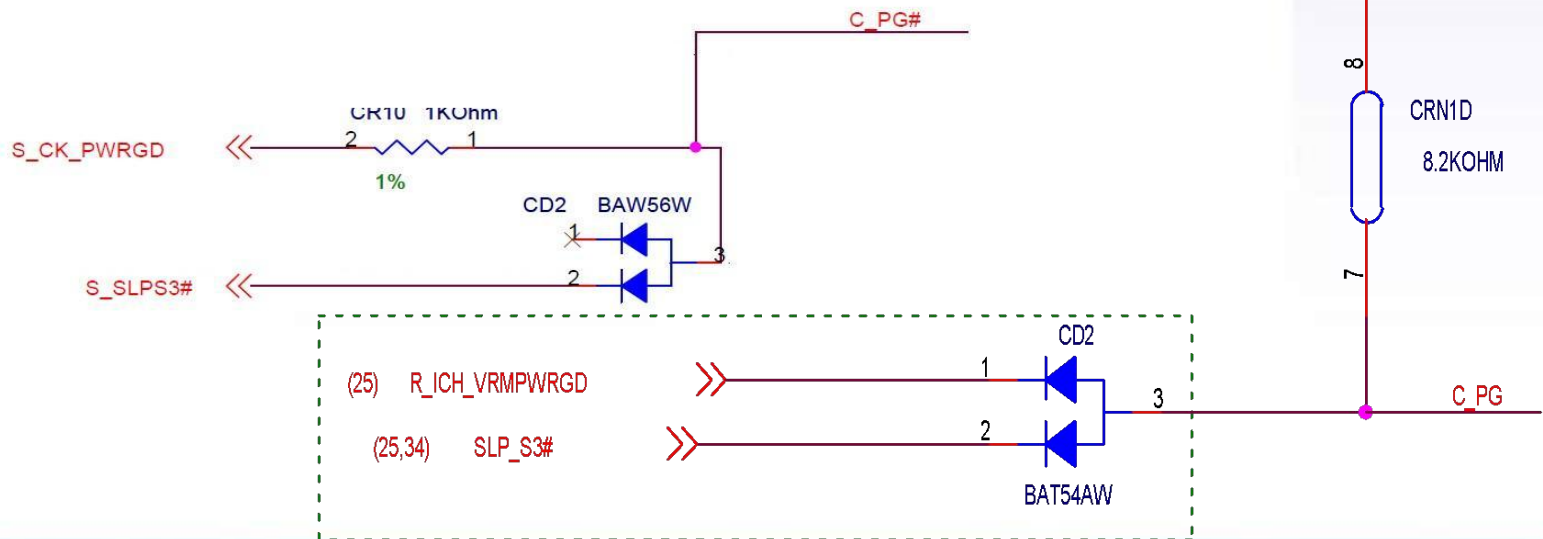

Repair Flow Chart

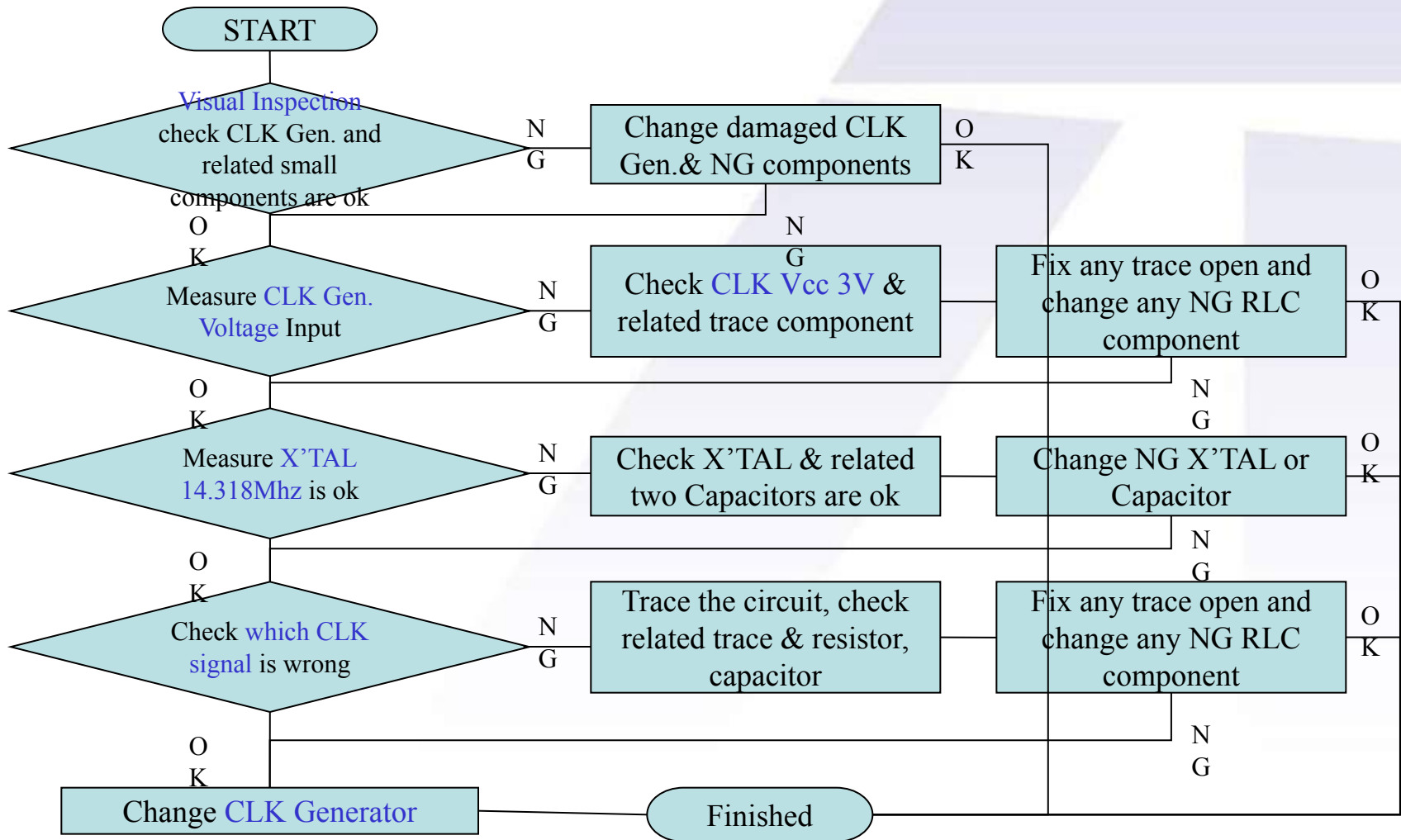

Repair Technique-Visual Inspection

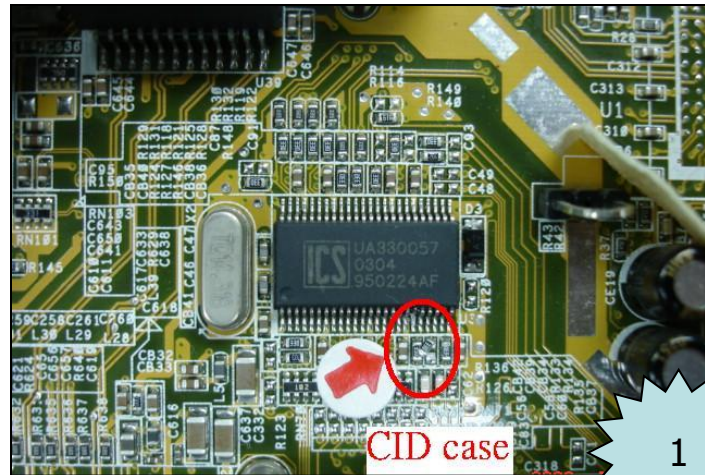

Visual Inspection to check Clock Generator and related small components are not damaged.

Repair Technique-Measure Vcc_CLK



Use Multi-Meter or Oscilloscope to measure **Clock voltage 3.3V** is ok.

Repair Technique-Measure CLK X'TAL

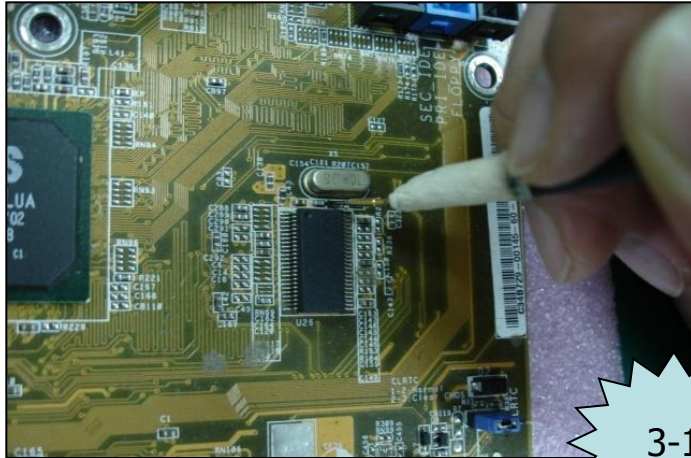

3-1

Use Oscilloscope to measure
Clock X'TAL 14.318Mhz is ok.



3-2

Repair Technique-Check Individual NG signal

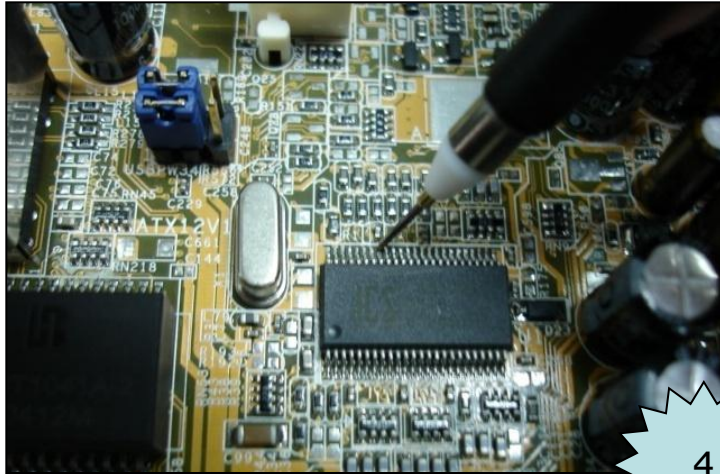

4

Use Oscilloscope to measure every individual CLK signal. If find error please trace the circuit to find it's connection.

If related RLC components are ok but CLK still is NG please try to **change CLK generator** at last.

Thank You!
