



SUV YETI





Studie 2005



2009





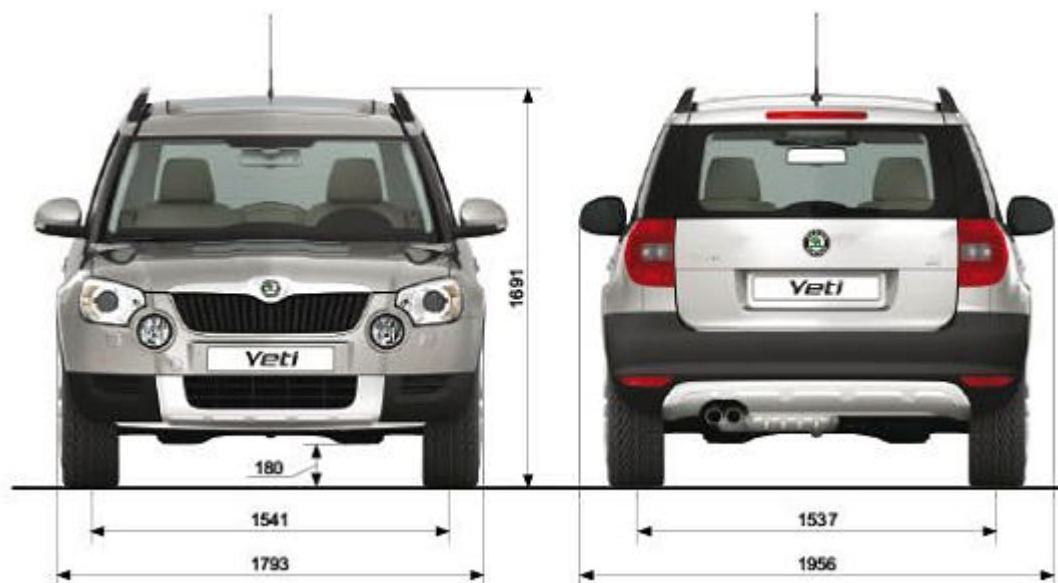
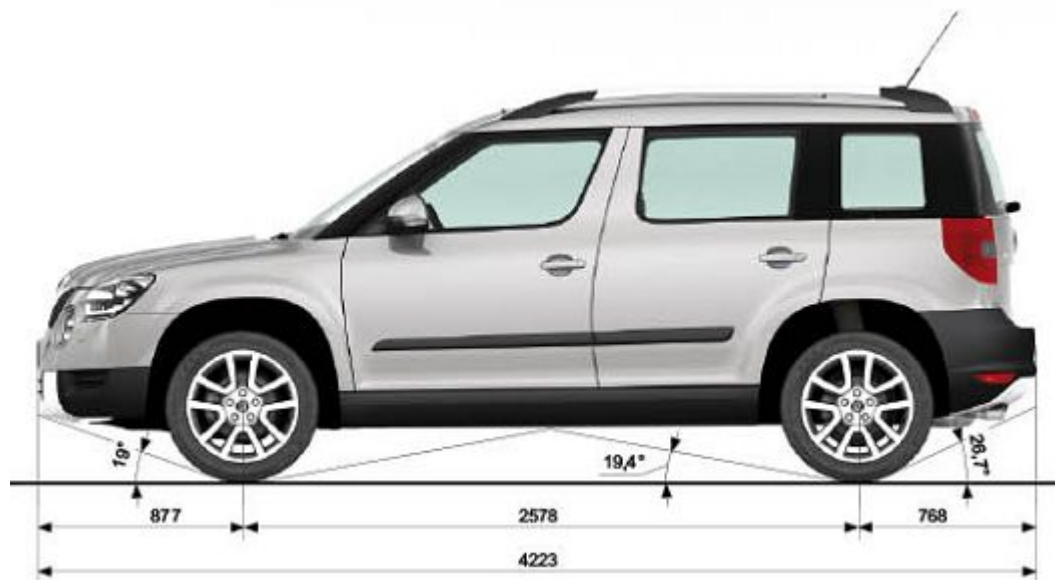



YETI x Octavia Scout

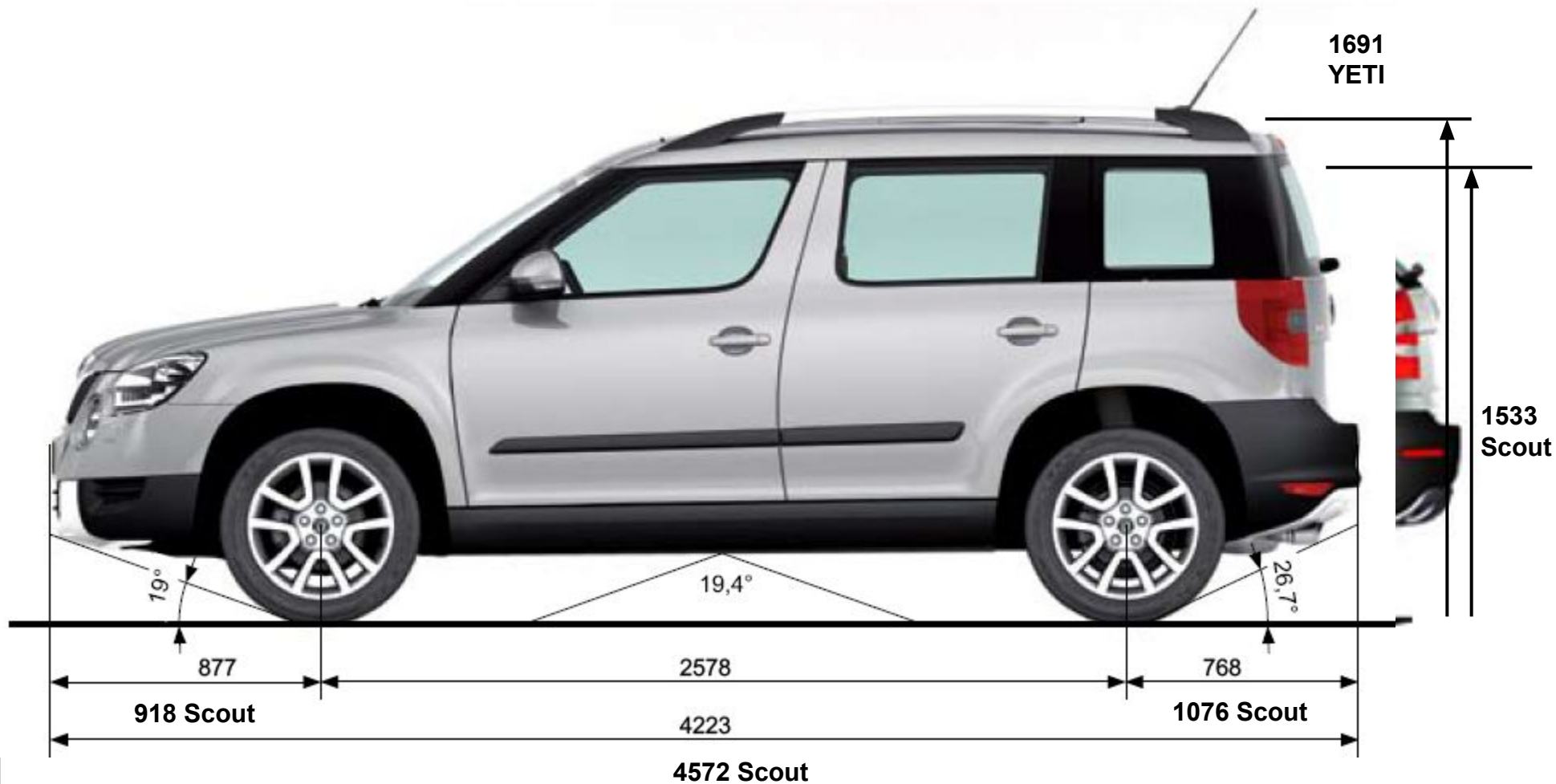



	YETI	Octavia SCOUT
Длина	4223 (- 349)	4572
Ширина	1793 (+ 9)	1784
Высота	1691 (+ 158)	1533
Пространство для багажа	2578	2578
Total mess	416/1760	580/1620





Двигатели

	Engine	Power		Emission	CO ₂ g/km*	4x2 / 4x4	SOP
Petrol	1,2 TSI	77kW	105 hp	EU V	158 (159)	MG (DSG)	09/09
	1,8 TSI	118 kW	160 hp	EU V	193	MG 4x4	05/2009
Diesel	2,0 TDI CR DPF	81 kW	110 hp	EU V	150 (169)	MG (MG 4x4)	11/2009
	2,0 TDI CR DPF	103 kW	140 hp	EU V	168	MG 4x4	05/2009
	2,0 TDI CR DPF	125 kW	170 hp	EU V	171	MG 4x4	11/2009



КОКПИТ

Active



Ambition



Experience







Varioflex

Система Varioflex позаимствована у модели Roomster.

Отличие от румстера:

- Средняя часть заднего сиденья может быть отодвинута назад на 70 мм
- Средняя часть сиденья длиннее на 35мм
- Сиденья заднего дивана могут сдвигаться в диапазоне до 80мм (110мм на Roomster)





Стандартный багажник с комплектом быстрого ремонта покрышки

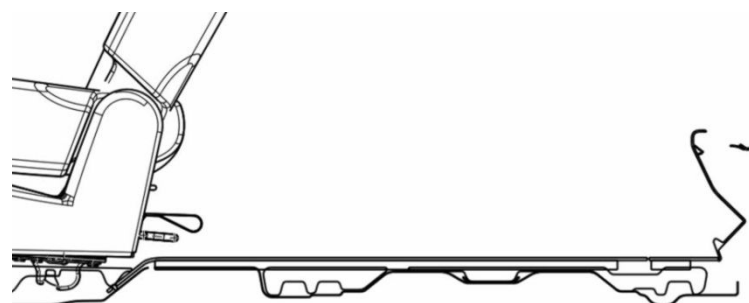
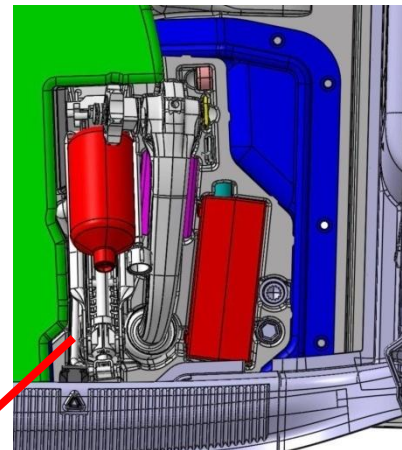
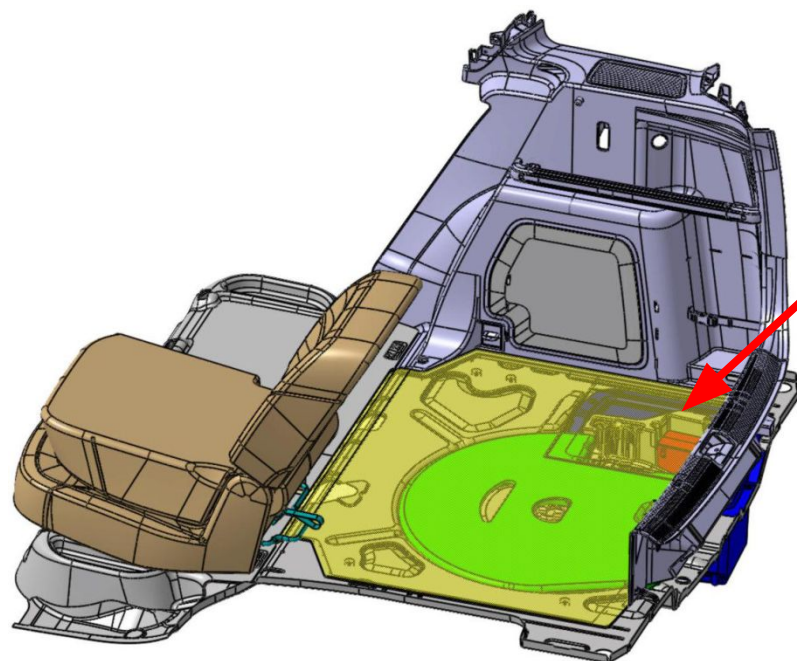

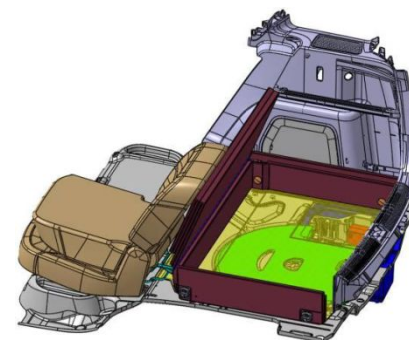
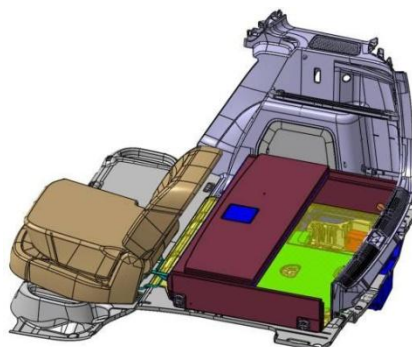
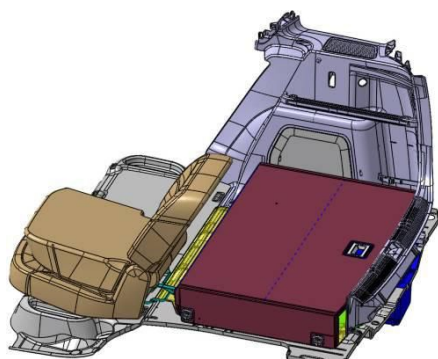
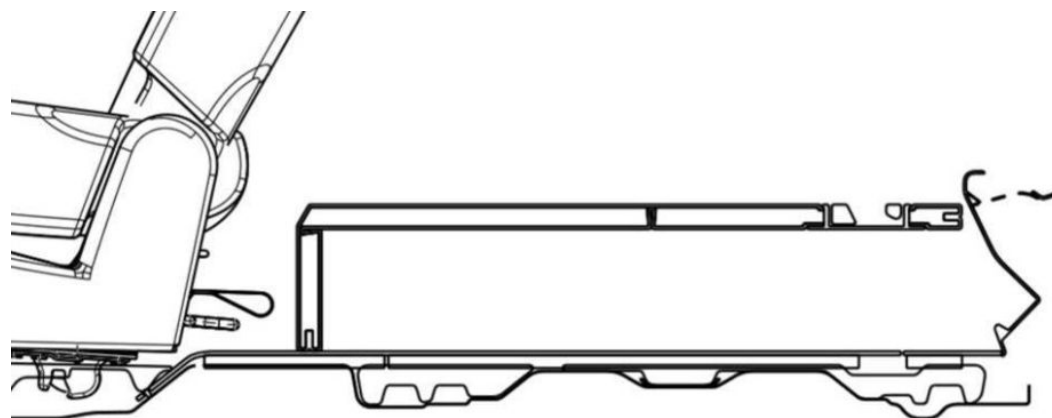
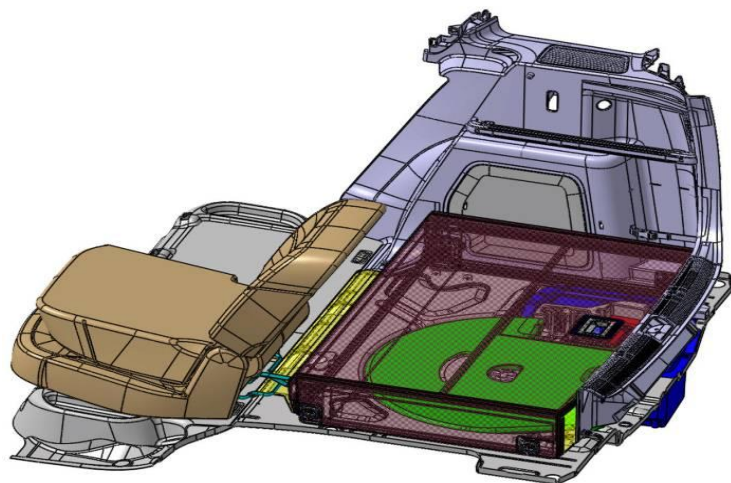



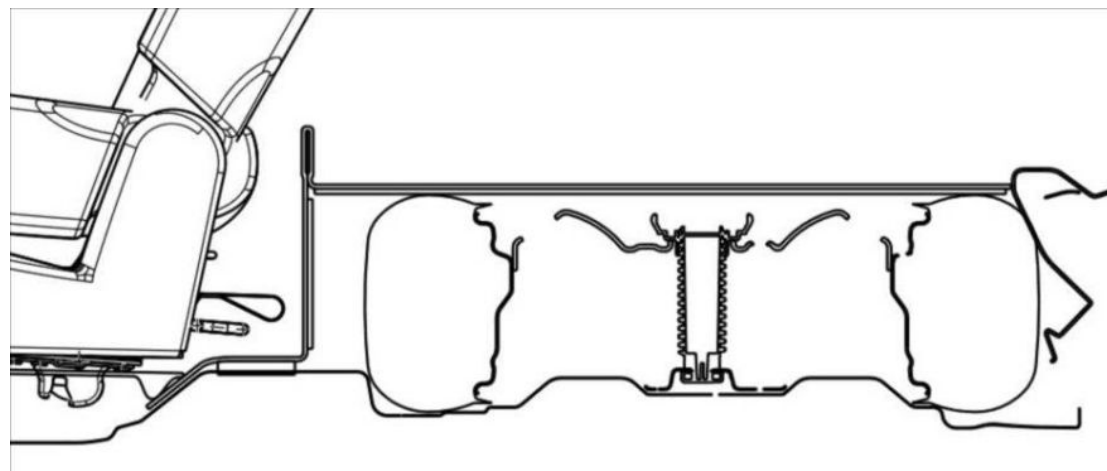
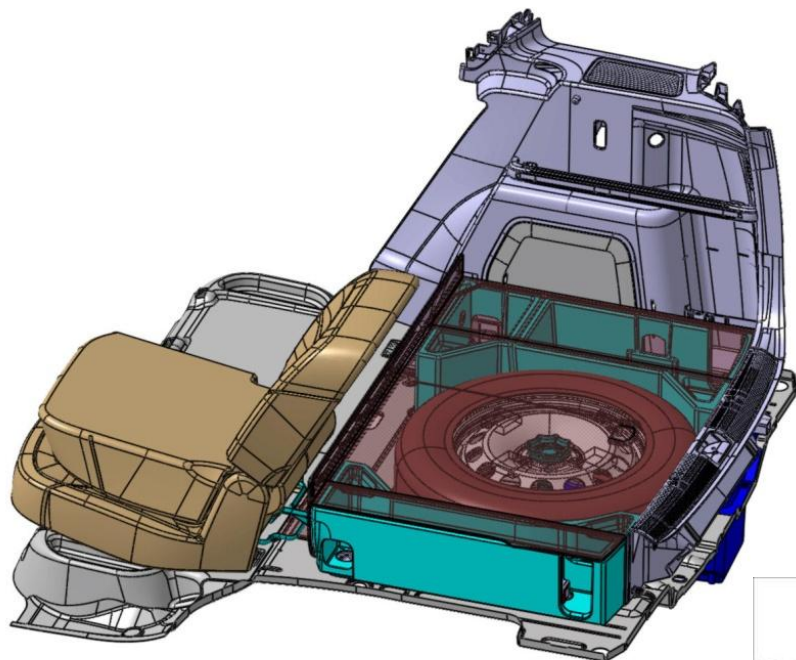

С запасным колесом



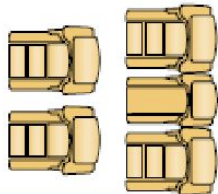
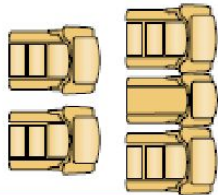
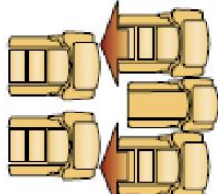
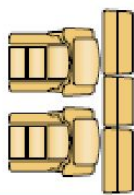

Варианты трансформации салона

	416	322
	405	310
	510	415
	1580	1485
	1760	1665

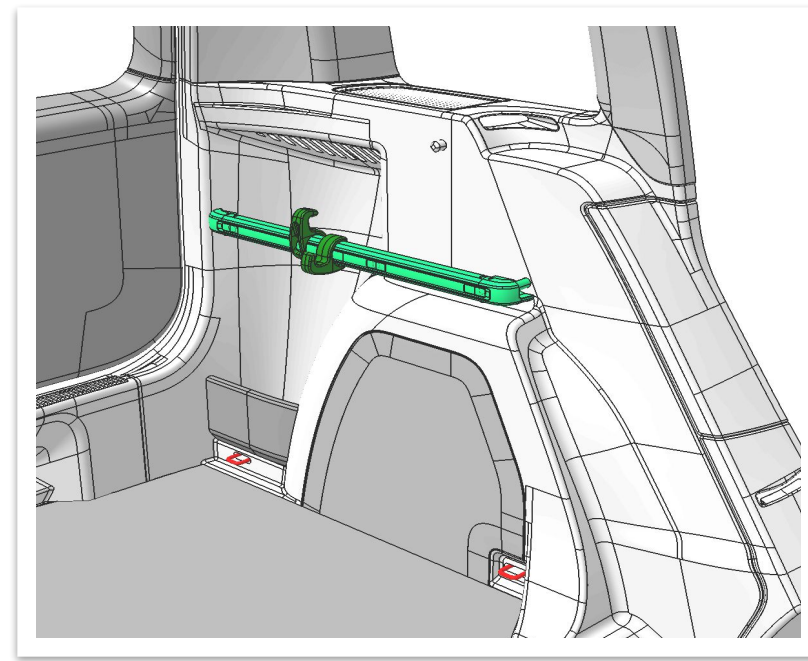
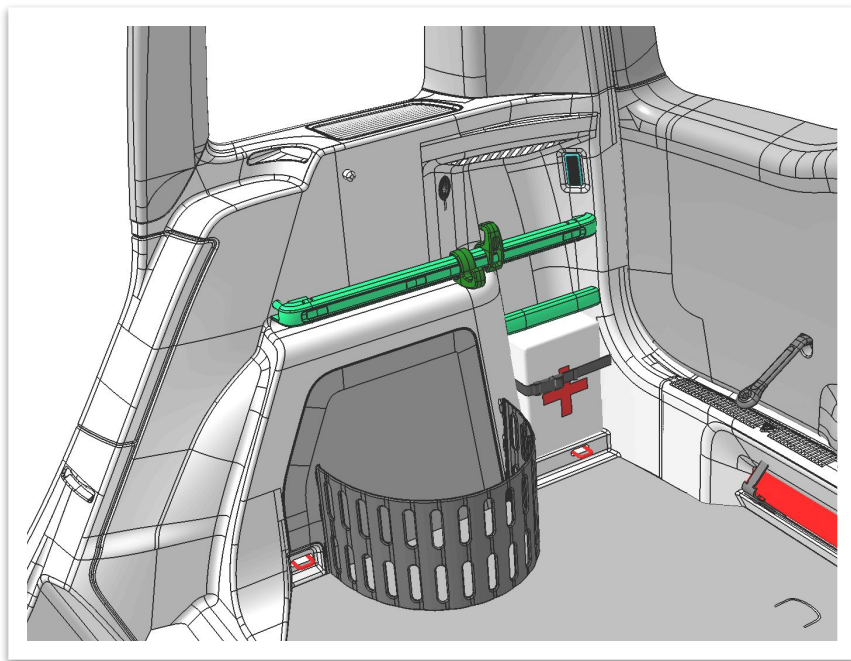

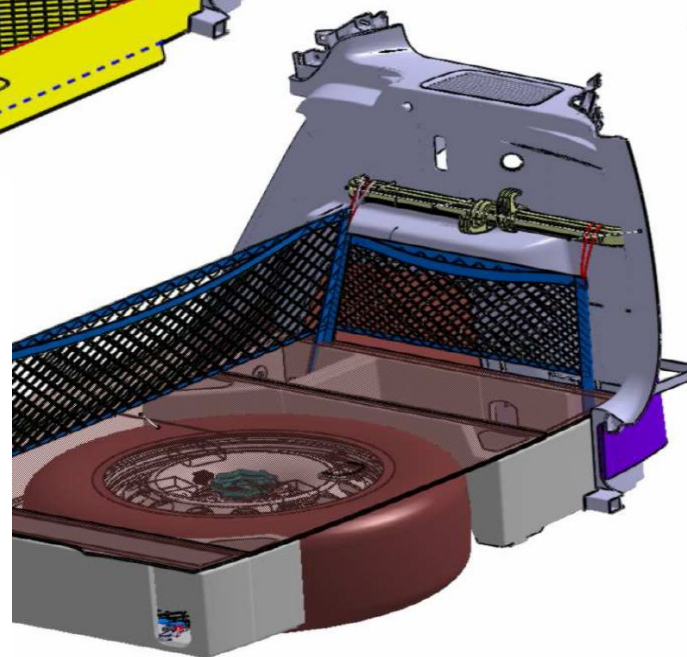
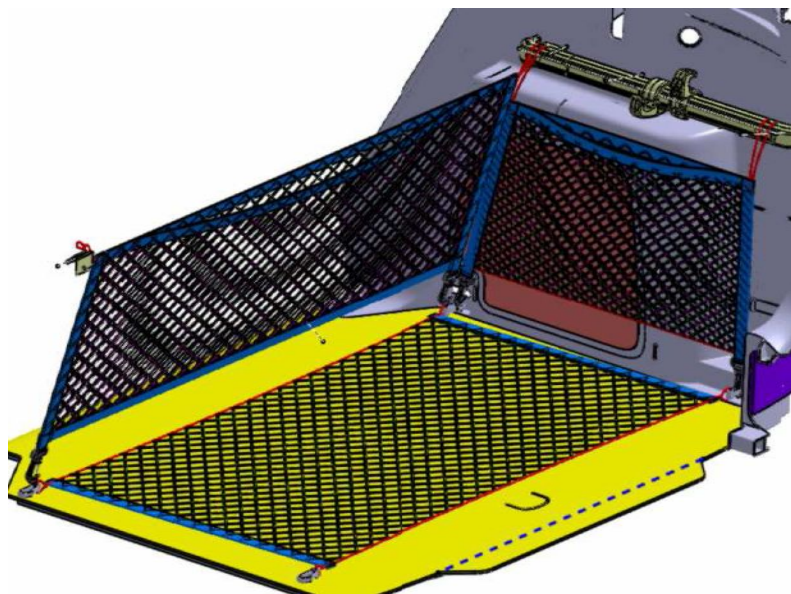



Автомобили конкуренты



Kia Sportage



Hyundai Tucson



Toyota RAV 4



Nissan Qashqai



Suzuki Grand Vitara



Сравнительные габариты

	YETI *	Tuscon*	RAV	Qashqai*	Compass	Vitara	CRV	Kuga*
Длина	4223	4325	4395	4315	4405	4445	4525	4443
Ширина	1793	1795	1855	1783	1810	1810	1820	1842
Высота	1691	1730	1685	1606	1630	1685	1675	1677
Колесная база	2578	2630	2560	2630	2635	2640	2630	2690
Багажное отд.	416/1760	325/1375	469/1552	410/1513	334/1277	398/1386	524/1532	360/1355
Масса прицепа	1600	1600	2000	1400	1500	2000	2000	2100
Total mess	2090	2170	2190	2085	1980	2070	2160	2130

* (4x2; 4x4)
Quele"AMS



YETI x Tiquan

	YETI (4x2; 4x4)	Tiquan (4x4)
Длина	4223	4427
Ширина	1793	1809
Высота	1691	1683
Колесная база	2578	2604
Багажное отд.	416/1760	470/1510
Масса прицепа	1600	2500 (offroad)
Total mess	2090	2240





K

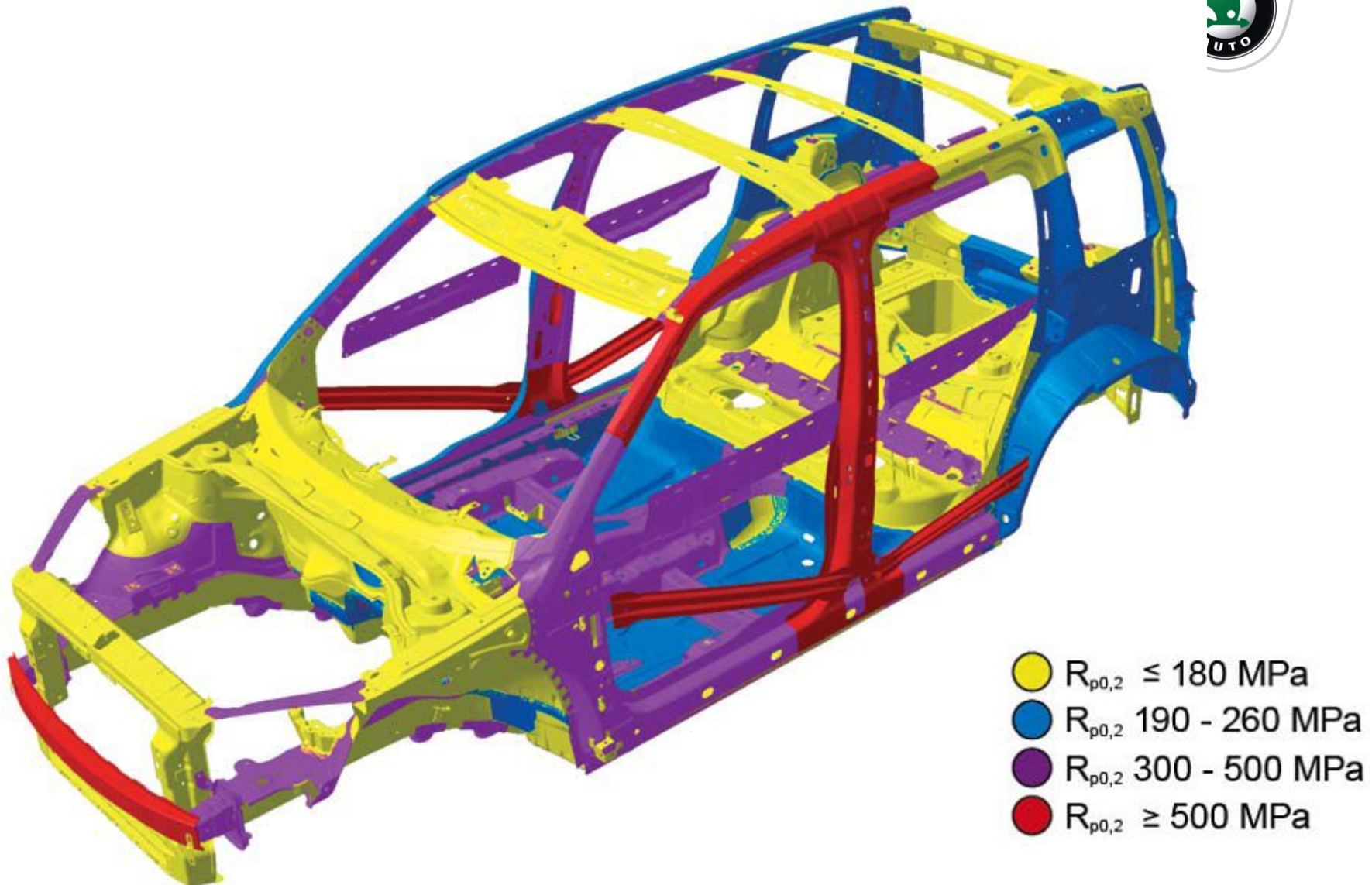



Кузов

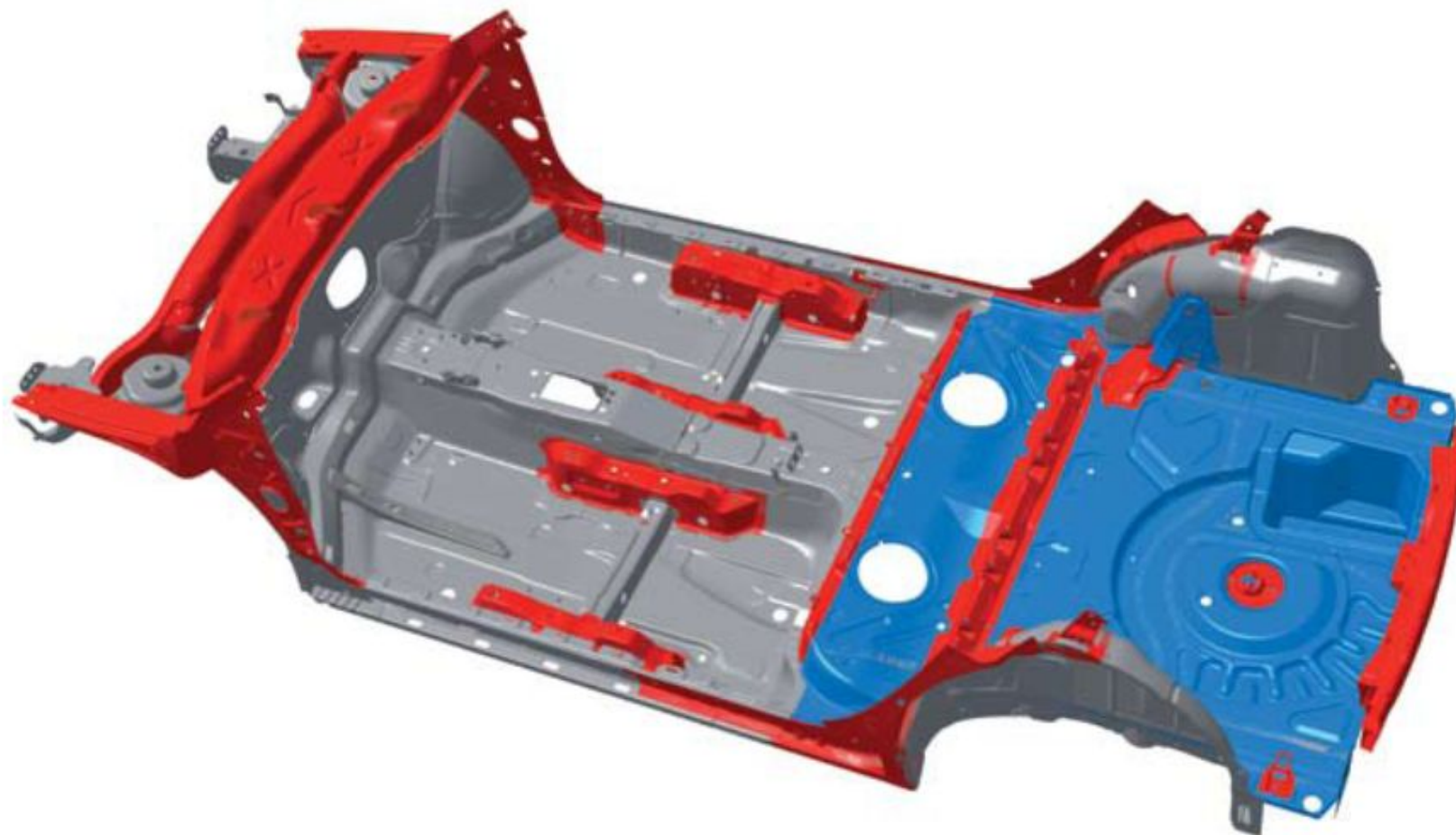



Кузов





Airbags





Боковой датчик удара





Боковой датчик давления





Контрольные лампы





Выключатель airbag переднего пассажира





Задний боковой airbag





Головной airbag





Преднатяжитель передних ремней безопасности





Рабочие позиции

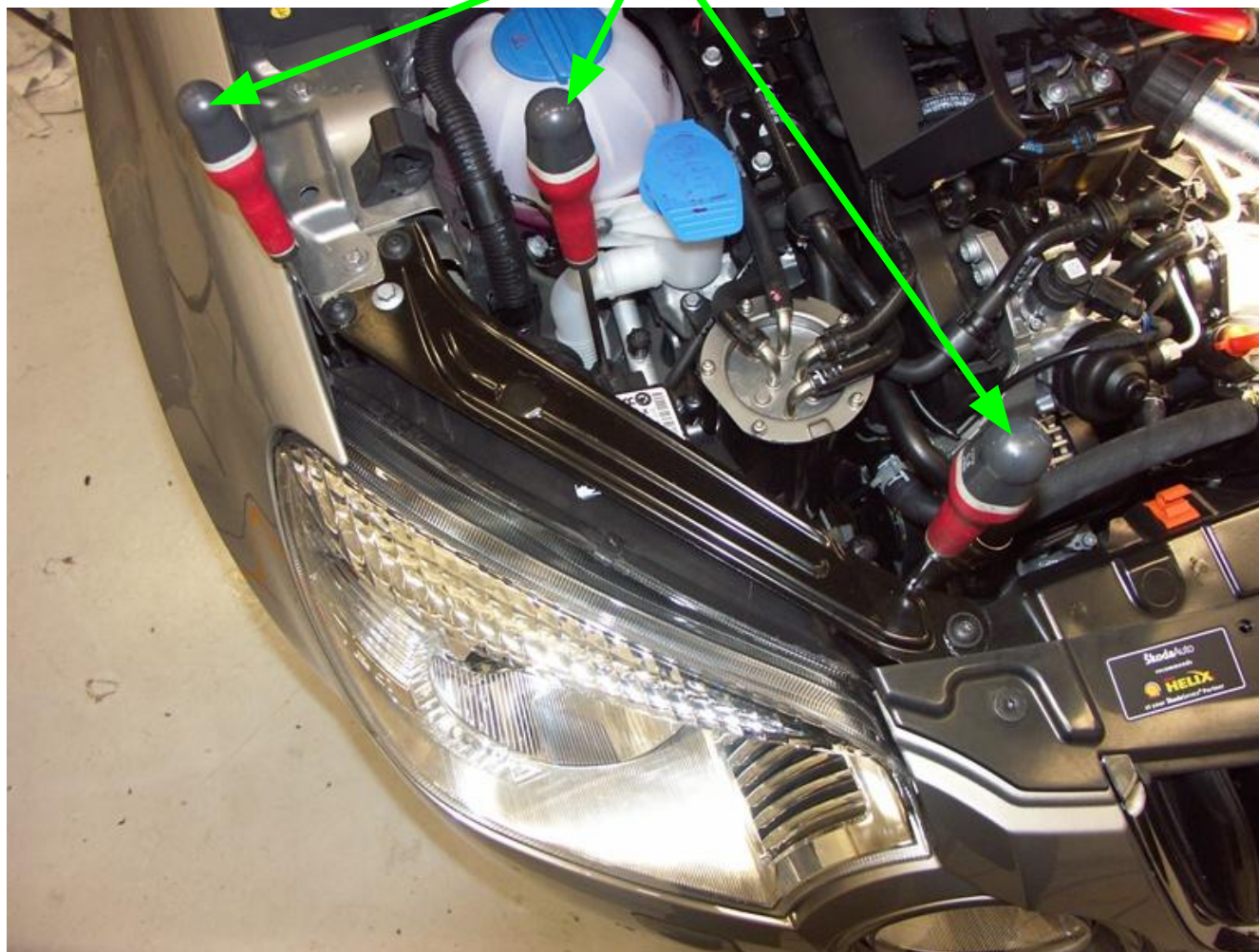





Панорамная сдвижная крыша

