

Электросистема машин серии PRT

Обозначение схем кодом из 3 букв

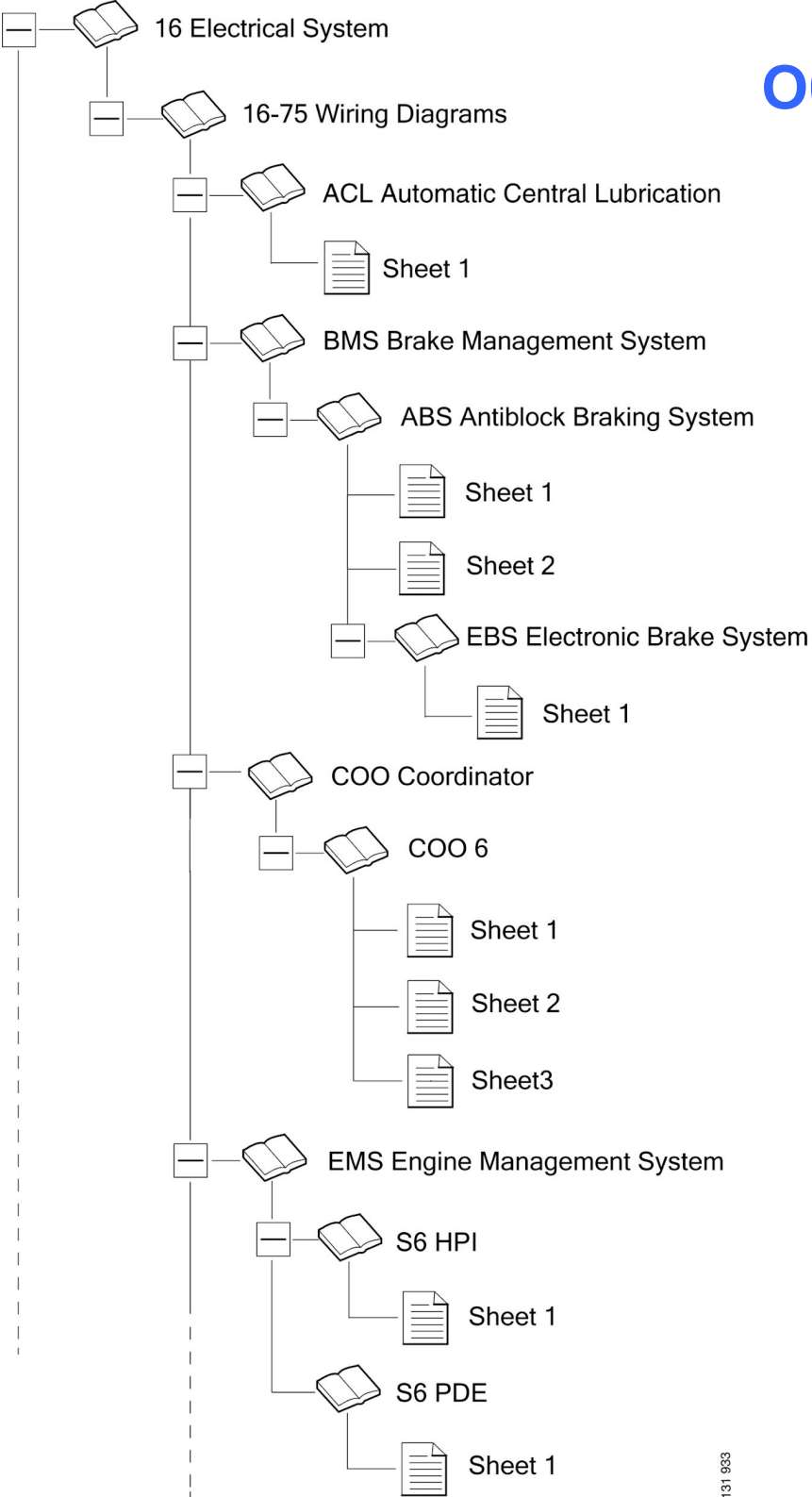

Информация о схеме в правом нижнем углу

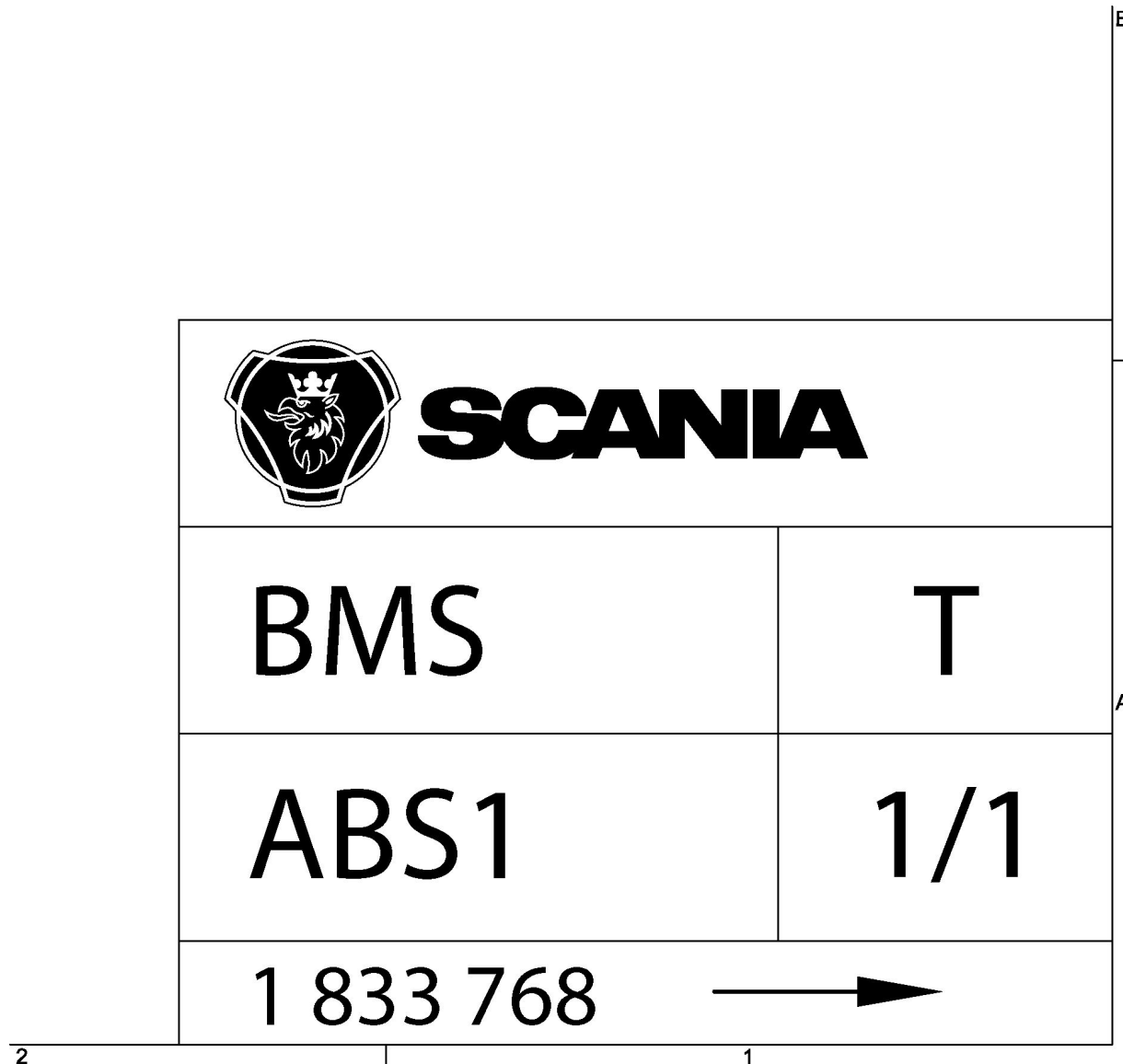

Новые обозначения проводов – 3-буквенный код системы и порядковый номер

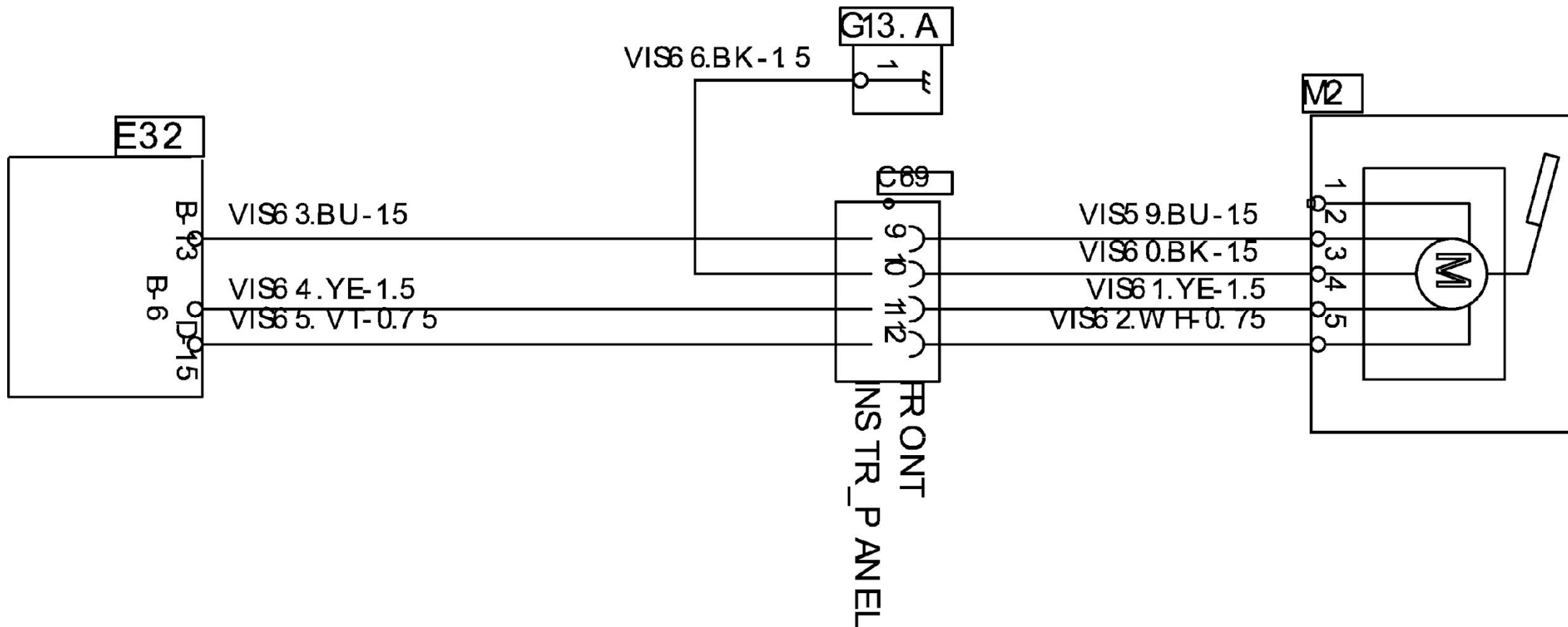

Один номер компонента может состоять из нескольких других

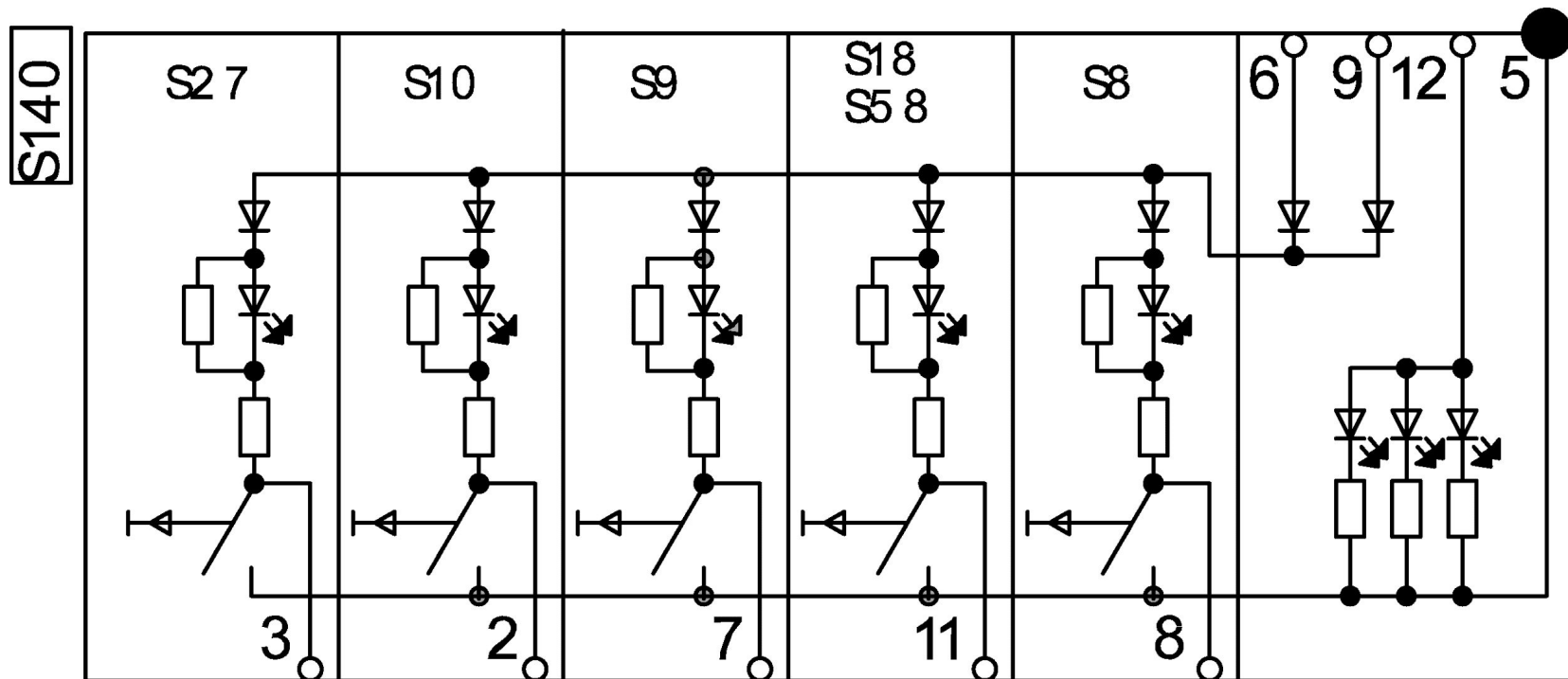

На схемах длинные провода имеют дублирование обозначения

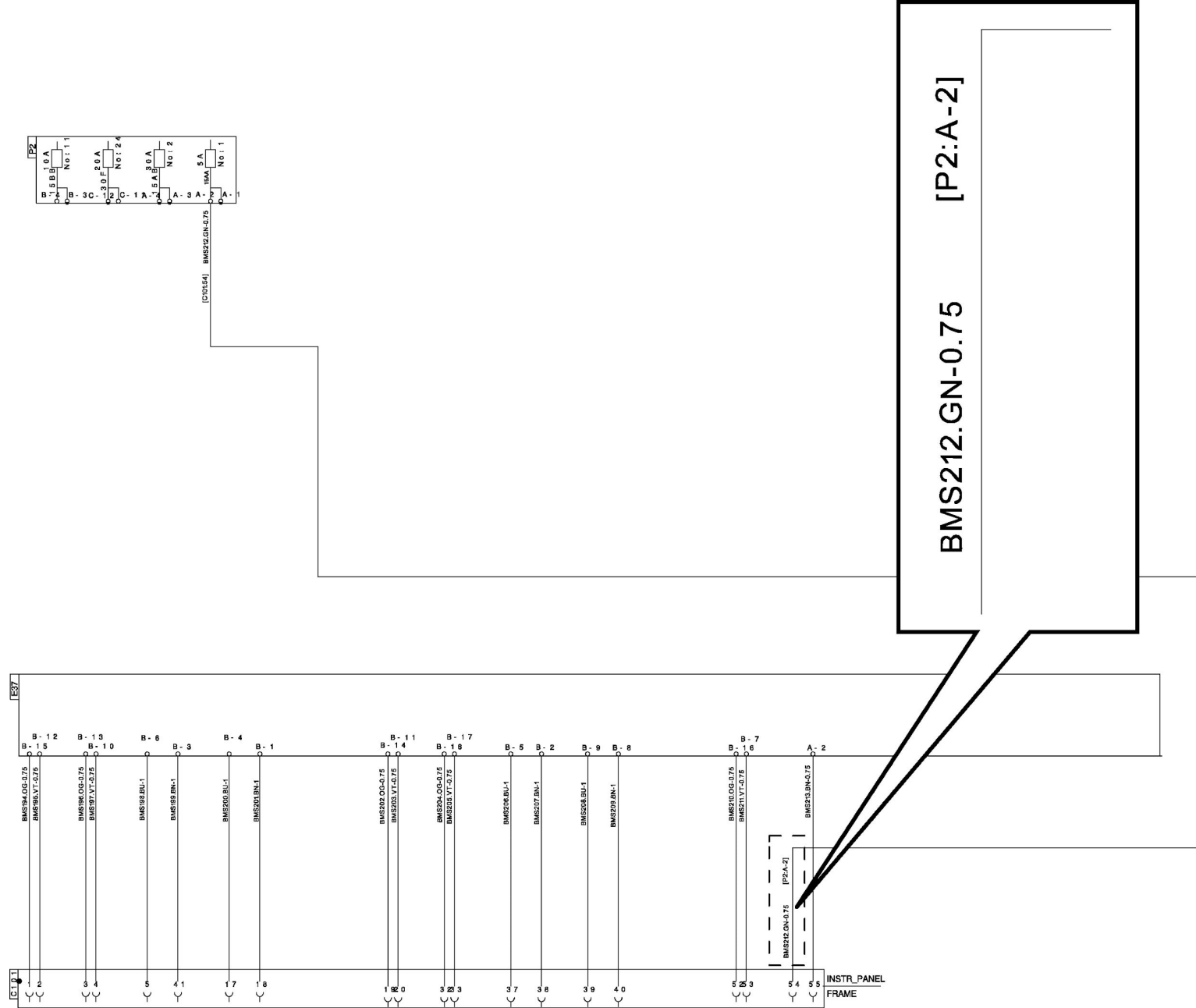

Сылка на использование других схем

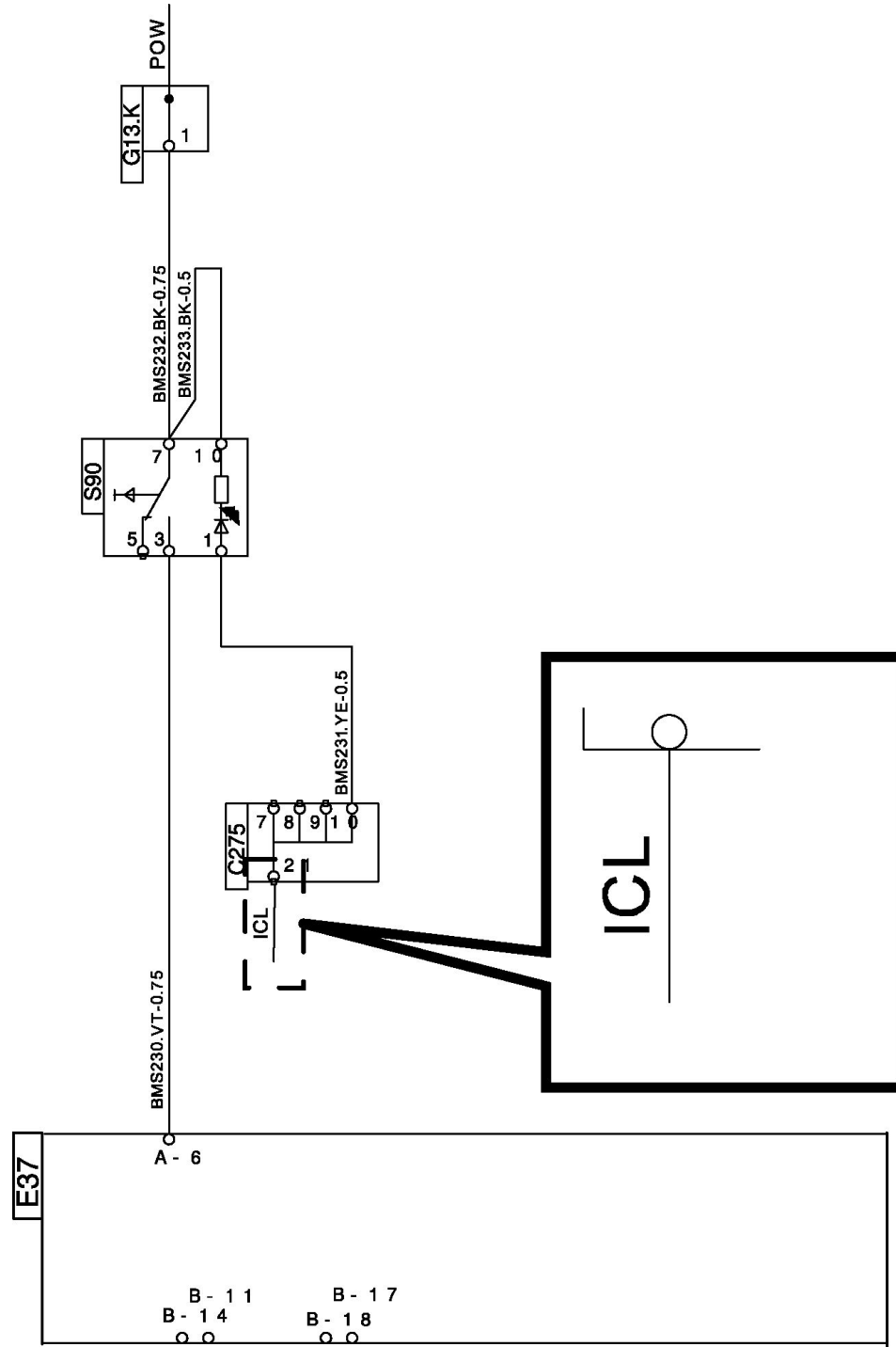

Расположение разъема в разных местах схемы

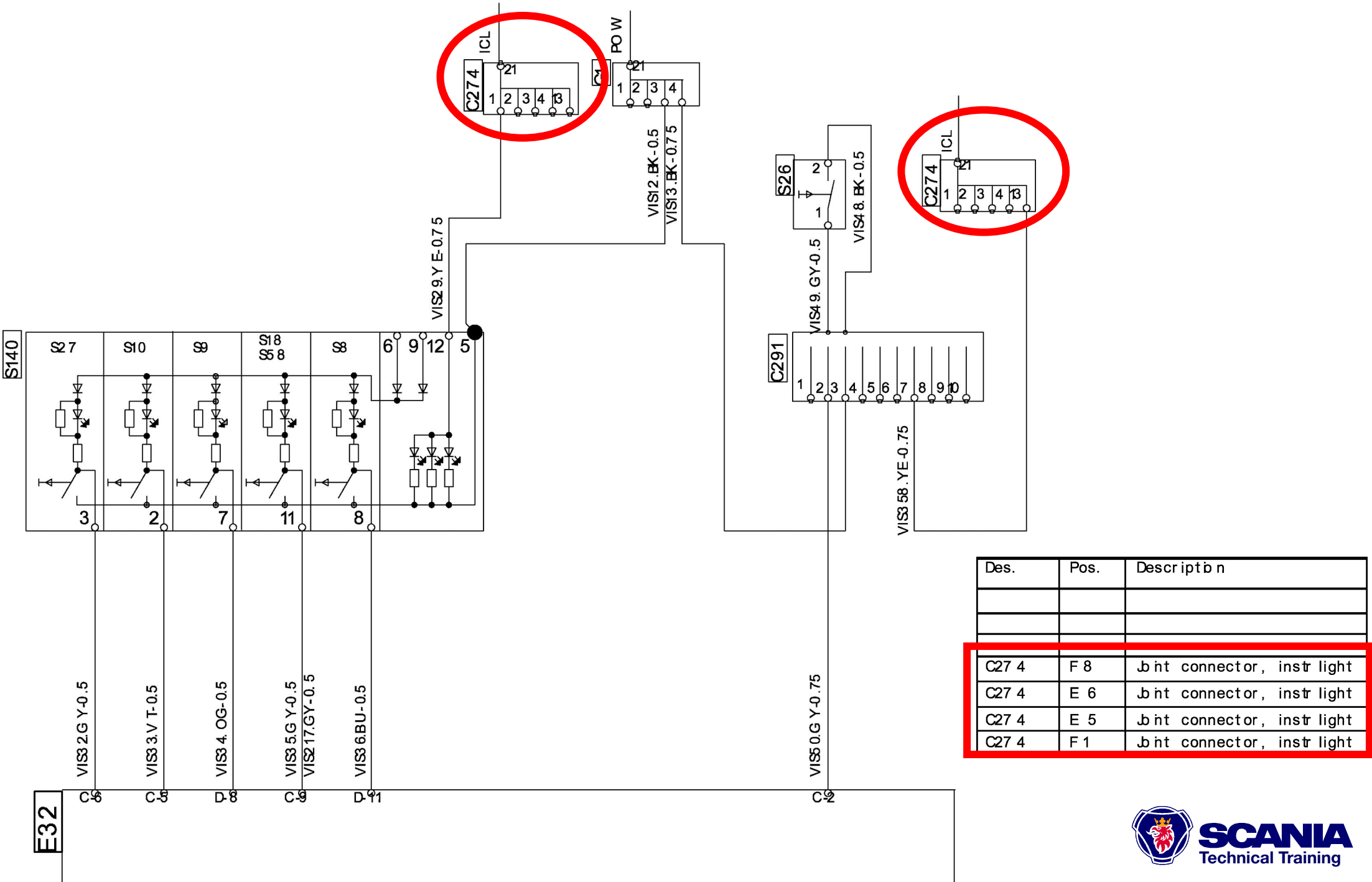

Обозначение разъема номером компонента

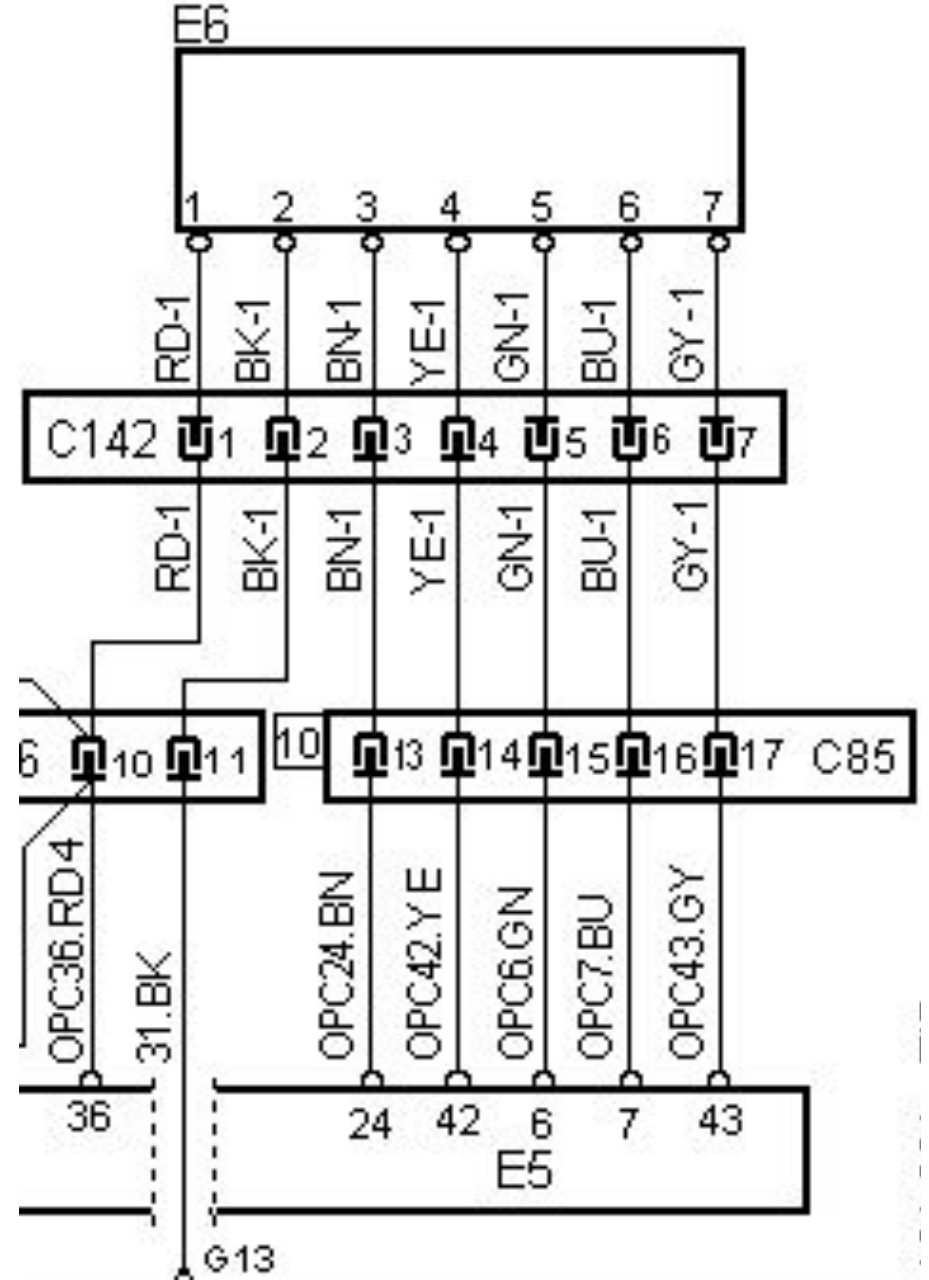
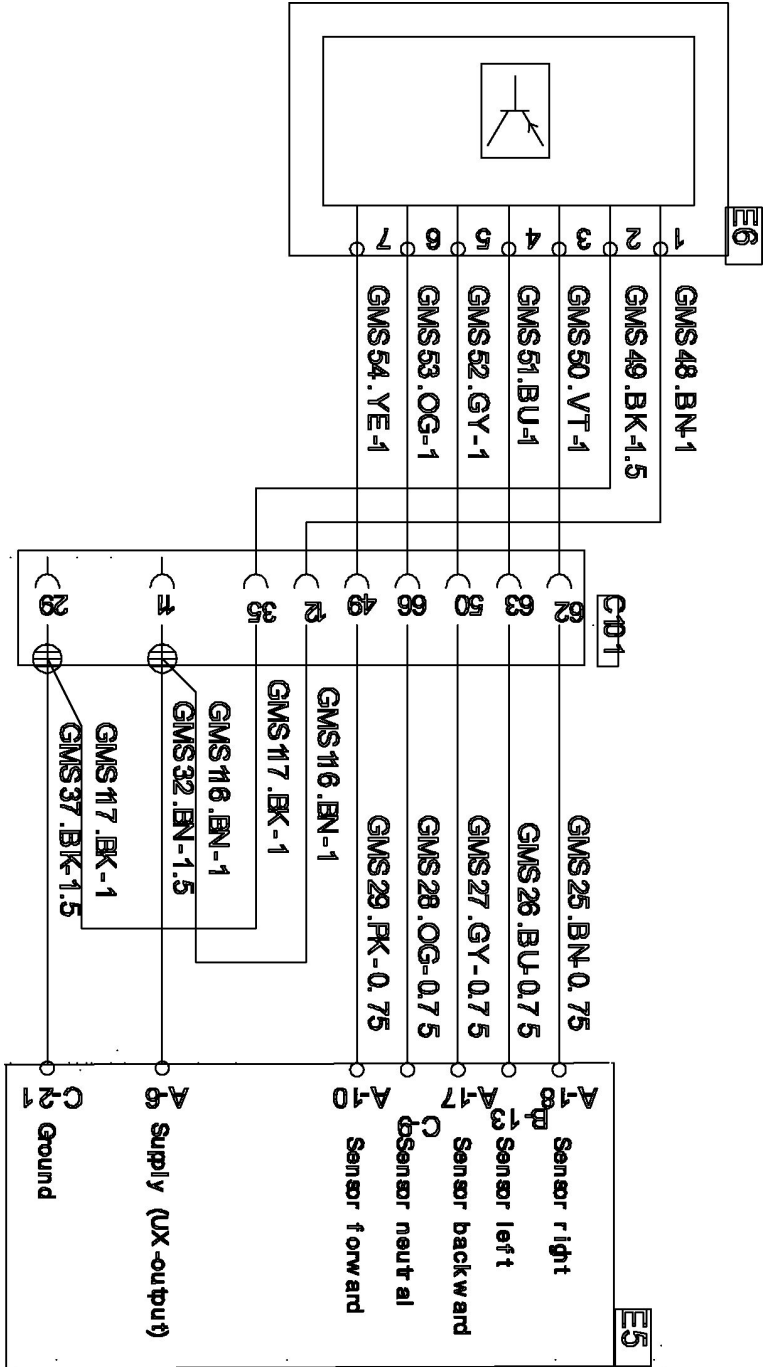

Цветовые обозначения проводов

Colour	Use
Yellow twisted with white	Yellow bus CAN H = yellow, CAN L = white.
Red twisted with white	Red bus CAN H = red, CAN L = white.
Green twisted with white	Green bus CAN H = green, CAN L = white.
Yellow	Instrument lighting
Red	30-supply 24V
Red-green	30-supply 12V
Green	15-supply 24V after fuse
Green-grey	15-supply 12V after fuse
White	15-supply/wake up
Black	31/ground

Wiring diagram ECU-system included

ACL
 AHS ATA (auxiliary heater)
 " WTA (auxiliary heater)
 " CTS (control unit)
 AUS AUS (radio system)
 ALT
 APS APS (air treatment)
 BMS BMS (ABS/EBS brake system)
 BWS BWS (bodybuilder interface)
 CBR
 CCS ACC (automatic climate system)
 COO COO (Coordinator)
 CSS CSS (crash safety)
 EMS EMS (engine management)
 FAS
 GMS GMS (gearbox-
 /retarder management)
 ICL ICL (instrument cluster)
 INL
 KIT

ECU-system included

Central lubrication
 Short-stop heater pump

 Radio system (Basic)
 Alert

 Wires for superstructure
 Communication radio

 Manual climate system

 FAS 2.0

 Internal lighting
 Kitchen equipment

Wiring diagram ECU-system included

KIT
 LAS LAS (locks and alarm)
 MIA
 MOP
 MIH
 POW
 "
 RDL
 REF
 ROH
 RTG RTG (gateway vehicle data)
 RTI RTI (PC-system)
 SCS
 SMS SMS (air suspension)
 SUA
 TAL
 TCO TCO (tachograph)
 VIS VIS (external lighting, etc)
 "
 WIW

ECU-system included

Kitchen equipment
 Manual central locking
 Rear-view mirror adjustment
 Mobile telephone
 Rear-view mirror heating
 Power supply
 Power supply ADR
 Diff lock operation
 Refrigerator
 Reflect

 Seat heating

 Sunvisor adjustment
 Tag axle lift

 Rotating beacon
 Headlamp level adjustment
 Window lifts