



ГОСУДАРСТВЕННЫЙ ТЕХНИЧЕСКИЙ УНИВЕРСИТЕТ

Institute of Nuclear Power Engineering and Applied Physics



Nizhny Novgorod State Technical University n.a. R. E. Alekseev

**Analysis of possible application of
high-temperature nuclear reactors to
contemporary large output steam
power plants on ships**

Made by:
student of
M16-YAE
D.N.Smirnov

Pressurized Water Reactor (PWR)

WORLD NUCLEAR
ASSOCIATION

A Pressurized Water Reactor (PWR)

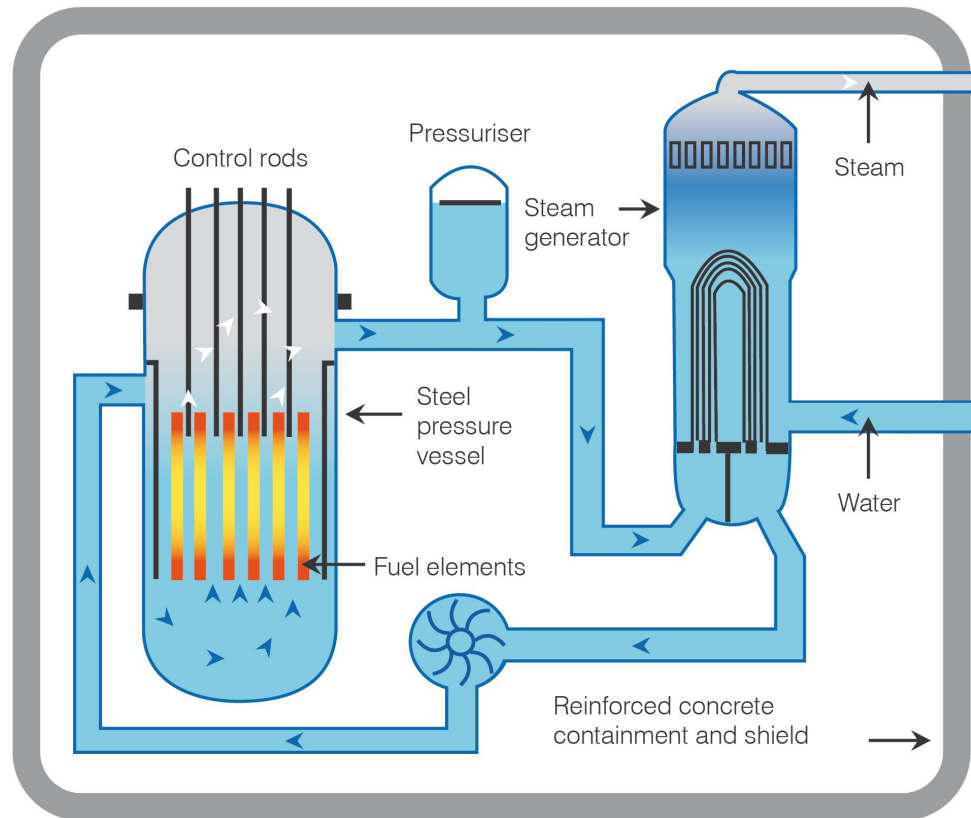

High Temperature Reactor (HTR)

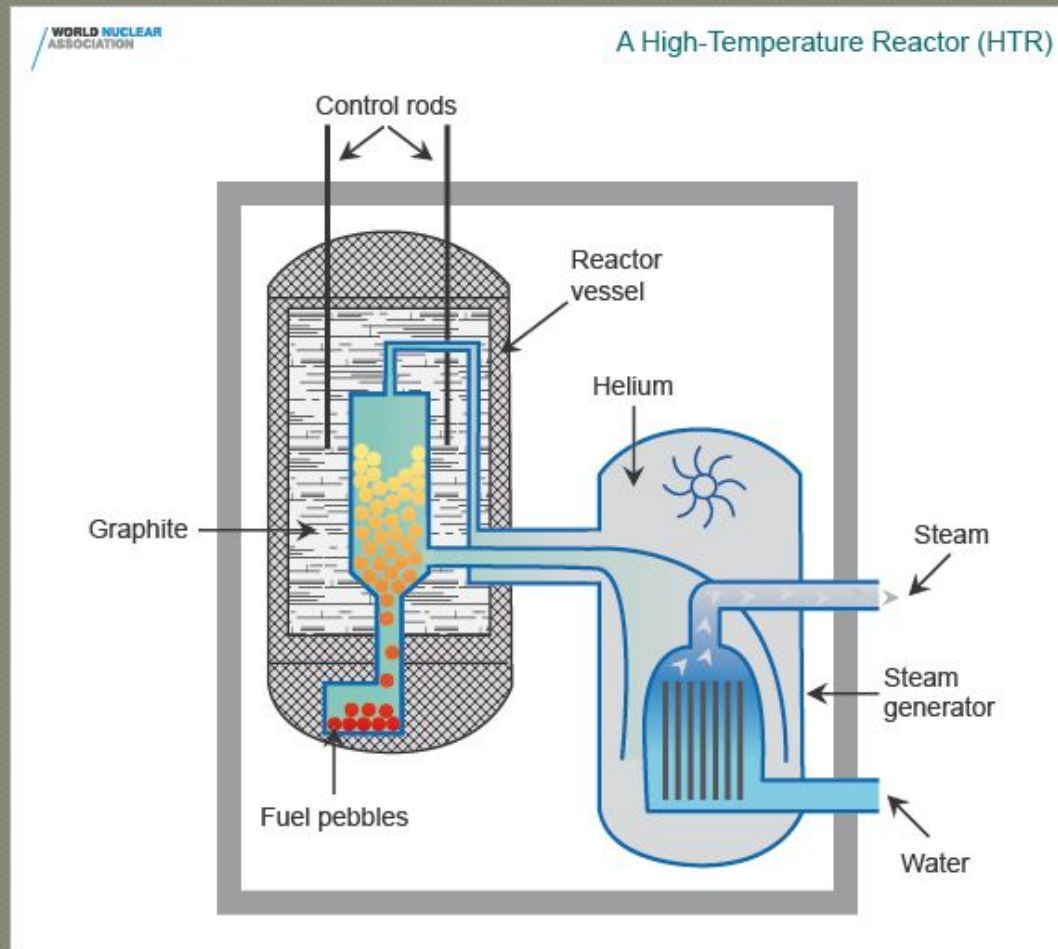

Types of presently used ship power plants

- **Pressurized Water Reactor (PWR)**
parameters of live steam in steam cycle: 300° C and 4 MPa
- **High Temperature Reactor (HTR)**
parameters of live steam in steam cycle: 535° C and 10 MPa

Simplified characteristics of reactivity losses as a result of Xe-135 poisoning during start-ups and power reduction

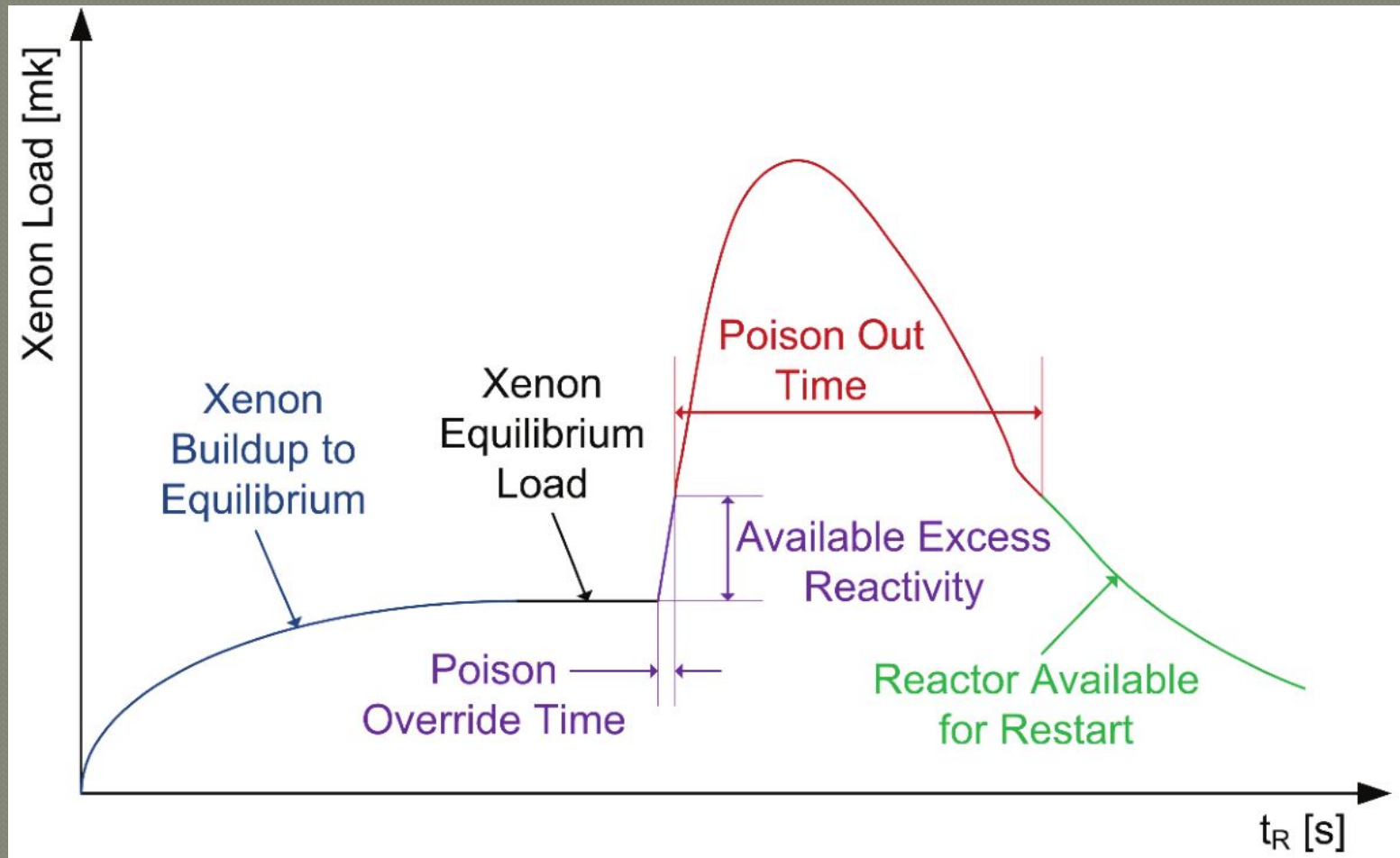

The “twin” system of ship power plant

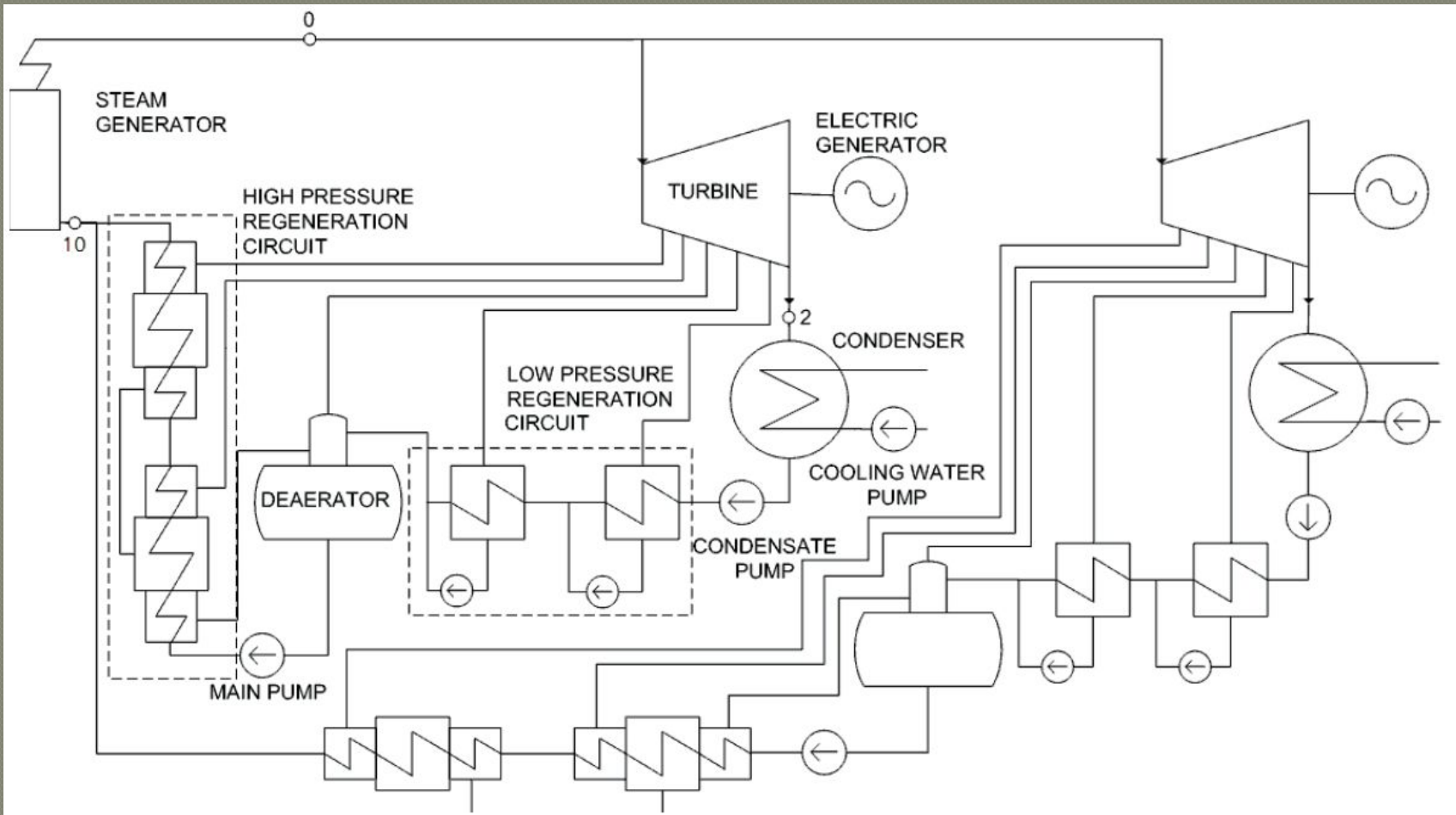

The cycle of power plant with interstage steam overheater

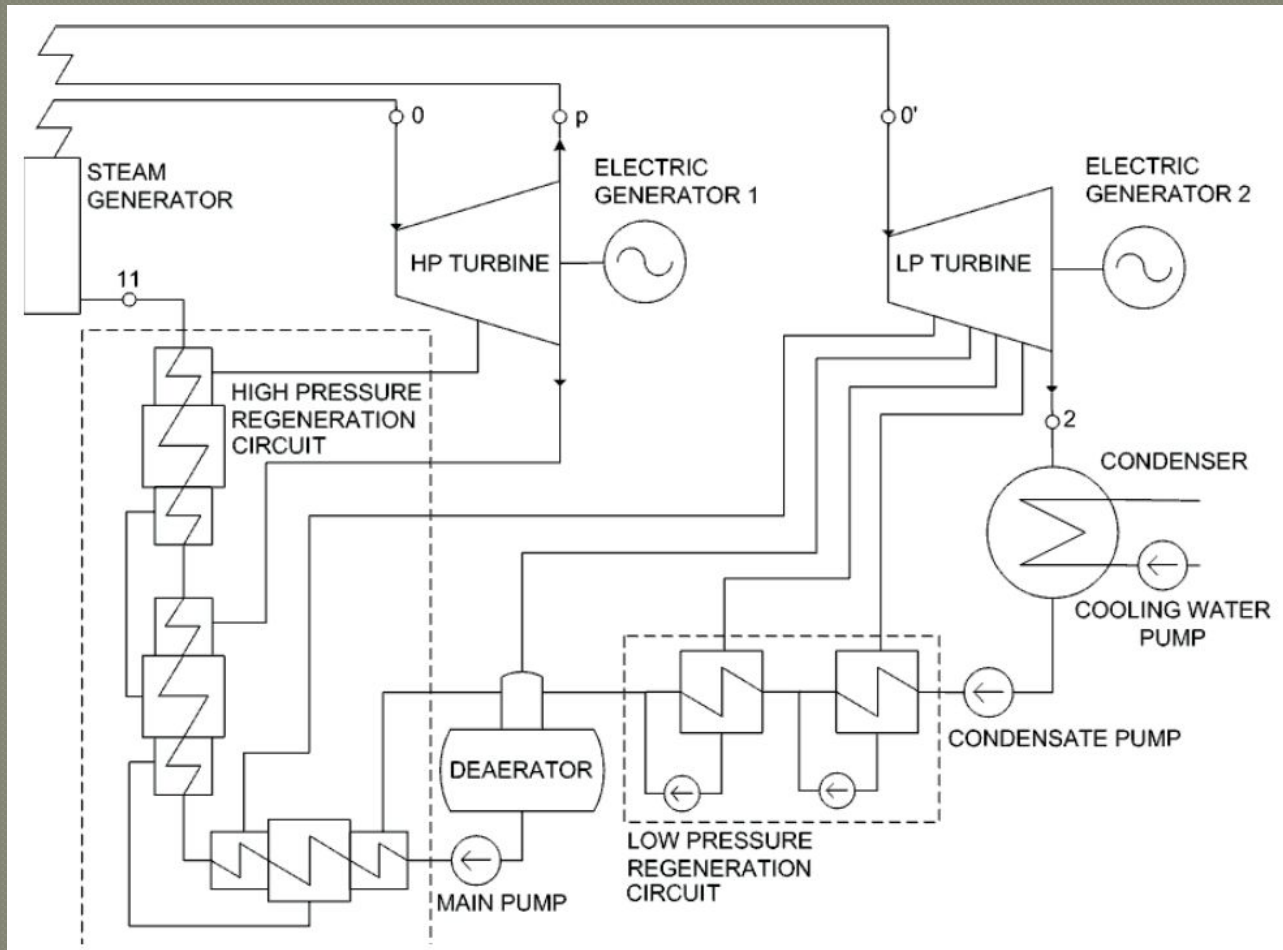

Results of analysis

Changes in the generator efficiency η_G , net electric efficiency η_{netto} , average mechanical efficiency of the turbines, η_T , the relative steam flux m_x/m_0 and the relative turbine inlet pressure in function of changes in the power plant load N_x/N_G for the “twin” cycle

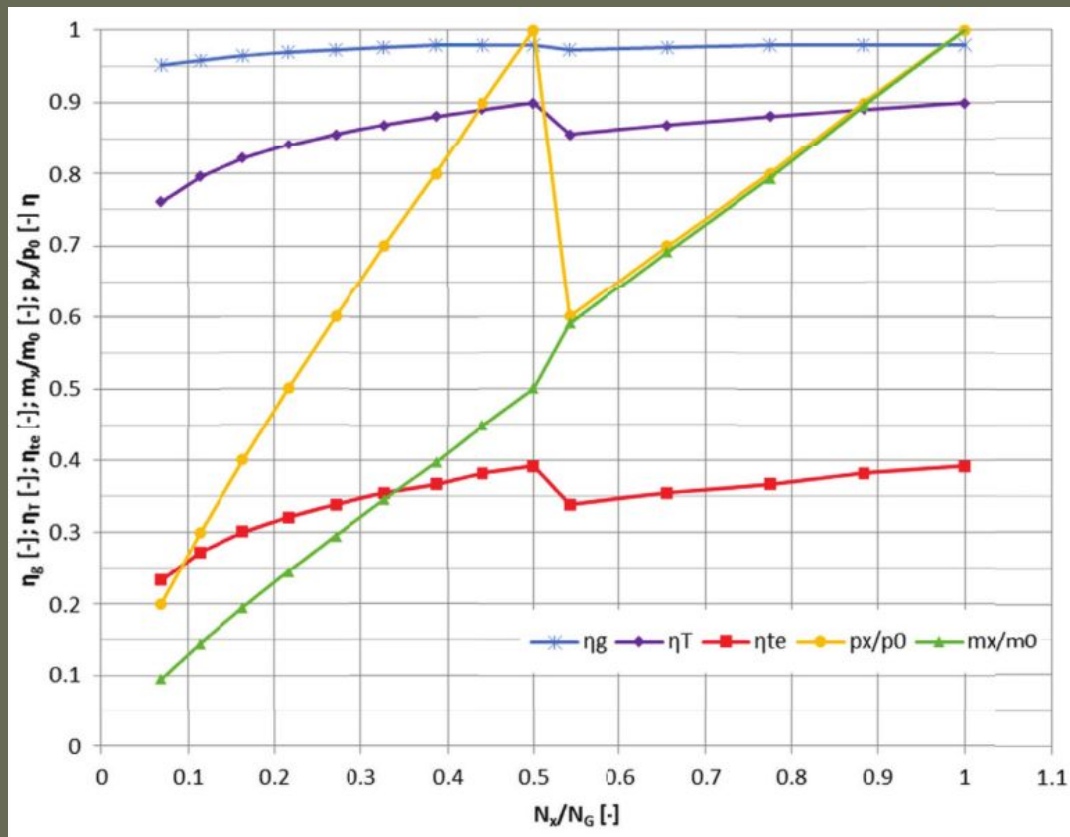

Results of analysis

Changes in the generator efficiency η_G , net electric efficiency η_{netto} , average mechanical efficiency of HP and LP part of the turbine, η_T , as well as the relative steam flux m_x/m_0 , all in function of change in the power plant load N_x/N_G for the cycle with interstage overheating

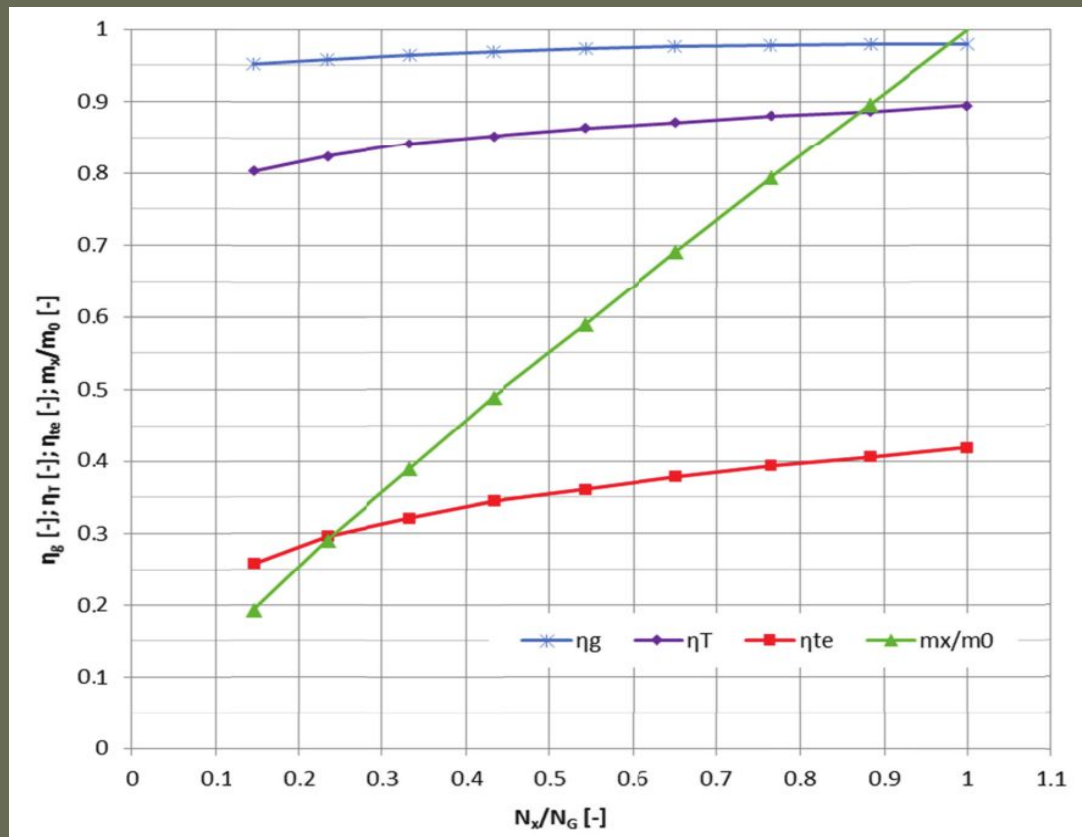

ABSTRACT

HTR reactors can effectively interact with thermodynamic cycles used at nuclear power plants at the present time.

The analysis of the efficiency characteristics that single-case steam turbines operating under a simple thermodynamic cycle, doubled or multiplied in ship power plant, are able to ensure a higher energy conversion efficiency of power plant at partial loads. The idea of application of high-temperature, graphite-moderated, helium-cooled nuclear reactors eliminates operational disadvantages of contemporary ship nuclear power plants by increasing their parameters over those of contemporary conventional steam power plants.

Application of HTR reactors improves hence profitability of ship nuclear power plants compared to today used PWR reactors, increases their safety and lowers hazards to the environment.

Thank you for
attention