

# Teoria Hibridizării Orbitalilor Atomici

Hibridizare  $sp^2$

Hibridizare  $sp$

Hibridizare  $sp^3$

Hibridizare  $d^3s$

Hibridizare  $sp^3d$

Hibridizare  $sp^3d^2$

Hibridizare  $sp^3d^3$

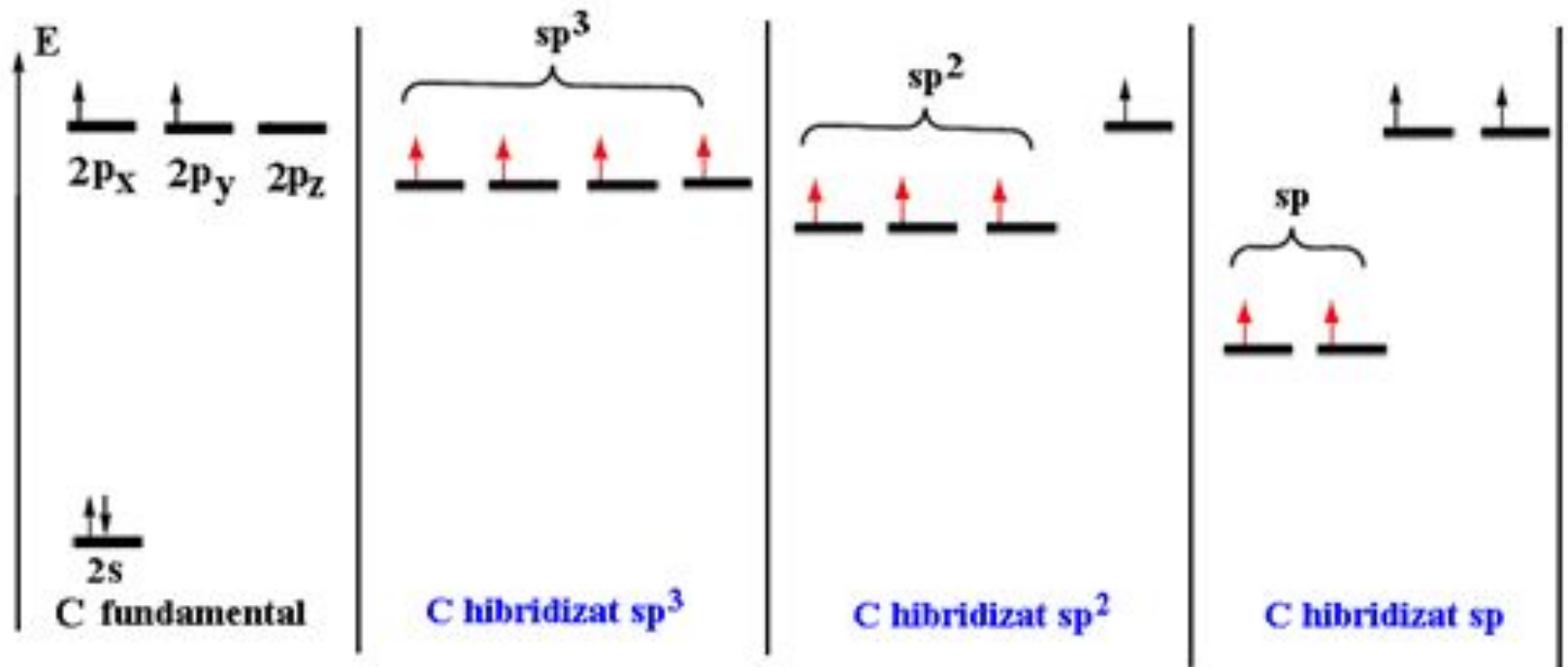

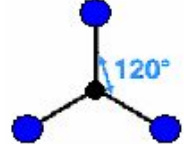
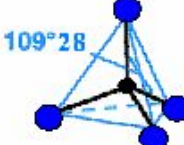
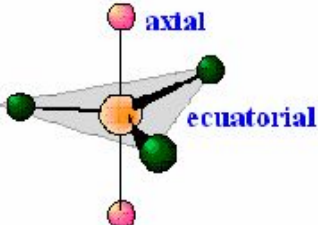
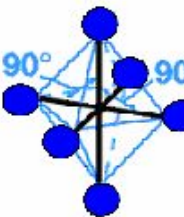
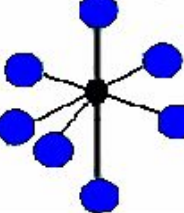

Fig. 3.16. Hibridizarea atomului de carbon.

<b>Număr de coordinare</b>	<b>Hibridizare</b>	<b>Geometrie</b>
<b>2</b>	<b>sp</b>	<b>Liniară</b>
<b>3</b>	<b>sp<sup>2</sup></b>	<b>Trigonală</b>
<b>4</b>	<b>sp<sup>3</sup></b>	<b>Tetraedrică</b>
<b>4</b>	<b>dsp<sup>2</sup></b>	<b>Plan-pătratică</b>
<b>5</b>	<b>dsp<sup>3</sup>, d<sup>3</sup>sp</b>	<b>Bipiramidal-trigonală</b>
<b>5</b>	<b>d<sup>2</sup>sp<sup>2</sup>, d<sup>4</sup>s</b>	<b>Piramidă pătratică</b>
<b>6</b>	<b>d<sup>2</sup>sp<sup>3</sup>, sp<sup>3</sup>d<sup>2</sup></b>	<b>Octaedrică</b>
<b>7</b>	<b>d<sup>3</sup>sp<sup>3</sup>, sp<sup>3</sup>d<sup>3</sup></b>	<b>Bipiramidal-pentagonală</b>

Tabel 3.2. Principalele tipuri de hibridizare și geometriile corespunzătoare.

Hibridizare	Geometrie	Exemple
sp	<p>Linara (unghiulara)</p>  <p>180°</p>	<p>BeCl<sub>2</sub> CO<sub>2</sub> C<sub>2</sub>H<sub>2</sub> HCN, O<sub>2</sub></p>
sp <sup>2</sup>	<p>Triunghiulara</p>  <p>120°</p>	<p>BF<sub>3</sub>, AlBr<sub>3</sub> BCl<sub>3</sub> NO<sub>3</sub><sup>-</sup> CO<sub>3</sub><sup>-2</sup> SO<sub>2</sub> C<sub>2</sub>H<sub>4</sub> O<sub>3</sub></p>
sp <sup>3</sup>	<p>Tetraedrica</p>  <p>109°28'</p>	<p>CH<sub>4</sub>, CCl<sub>4</sub>, NH<sub>4</sub><sup>+</sup> PO<sub>4</sub><sup>-3</sup>, SO<sub>4</sub><sup>-2</sup>, ClO<sub>4</sub><sup>-1</sup> NH<sub>3</sub>, H<sub>3</sub>O<sup>+</sup>, PCl<sub>3</sub> H<sub>2</sub>O, F<sub>2</sub>O C<sub>2</sub>H<sub>6</sub></p>
sp <sup>3</sup> d	<p>Bipiramida triunghiulara</p>  <p>axial ecuatorial</p>	<p>PCl<sub>5</sub> PF<sub>5</sub> Fe(CO)<sub>5</sub> SCl<sub>4</sub> SF<sub>4</sub> ICl<sub>3</sub> XeF<sub>2</sub> ClF<sub>3</sub></p>
sp <sup>3</sup> d <sup>2</sup>	<p>Octaedrica</p>  <p>90°</p>	<p>SF<sub>6</sub> XeF<sub>4</sub> ICl<sub>4</sub><sup>-</sup> XeOF<sub>4</sub> [AlF<sub>6</sub>]<sup>-1</sup> [PF<sub>6</sub>]<sup>-1</sup> ClF<sub>5</sub></p>
sp <sup>3</sup> d <sup>3</sup>	<p>Bipiramida pentagonala</p> 	<p>IF<sub>7</sub> XeF<sub>6</sub></p>

# Hibridizare sp

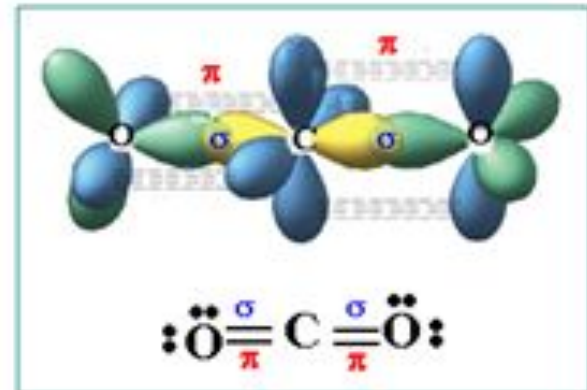
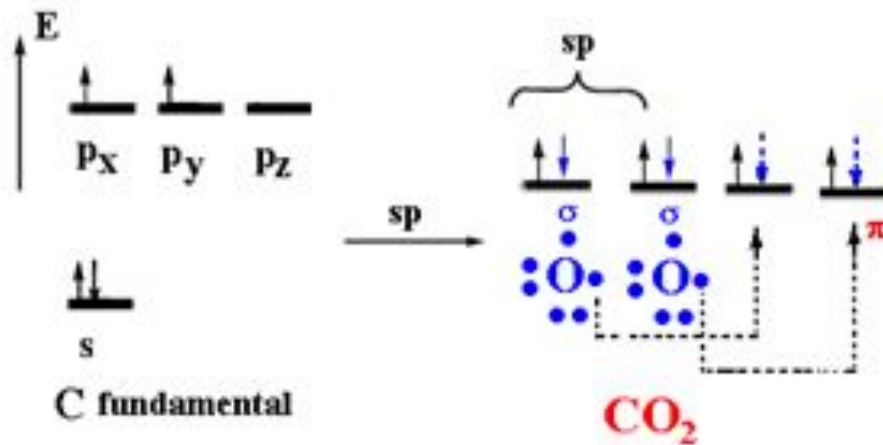
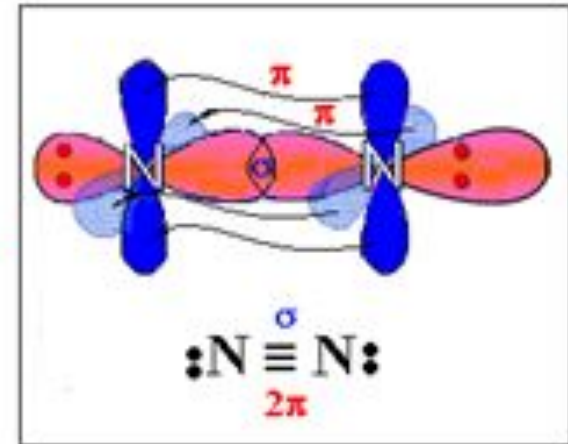
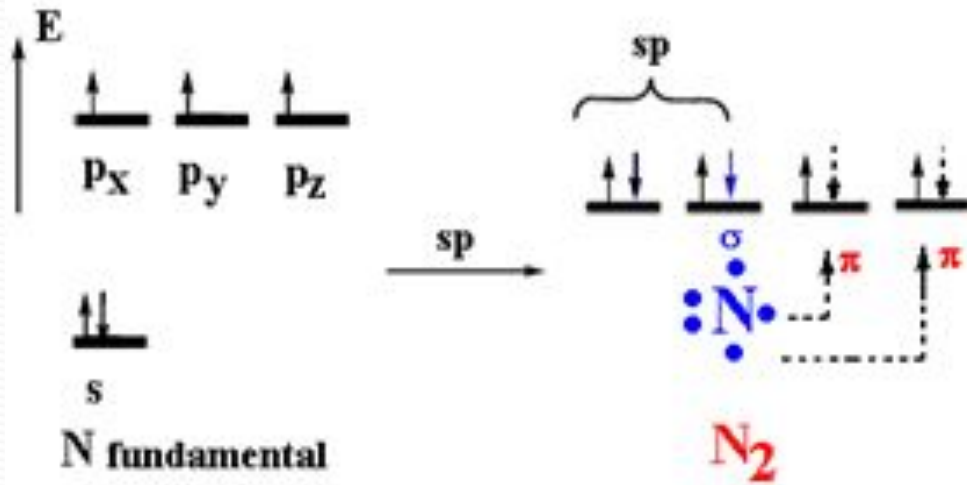

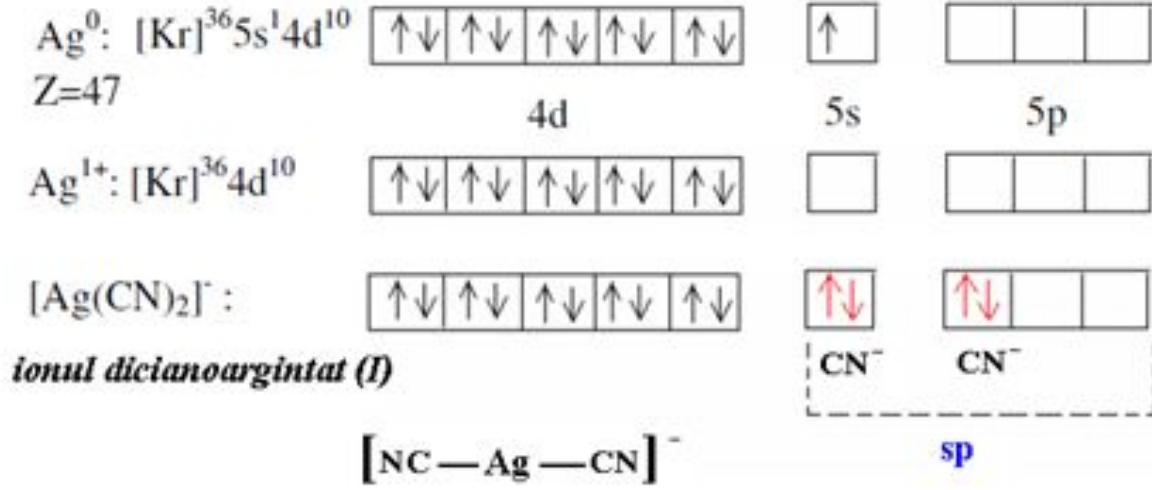

## 2. Hibridizare $sp^2$

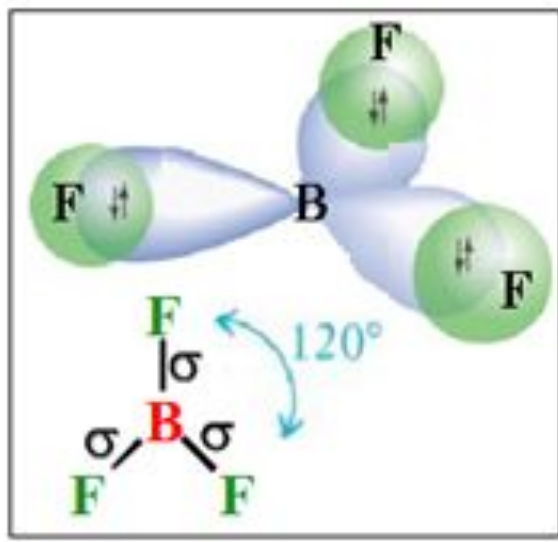
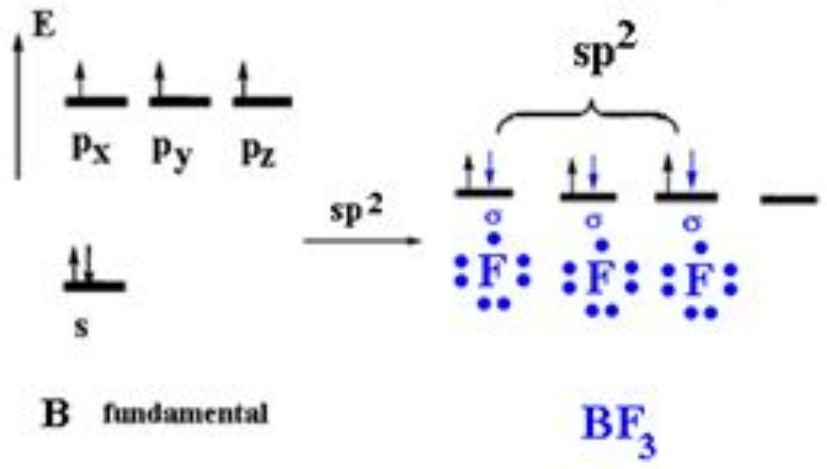

### 3. Hibridizare $sp^3$

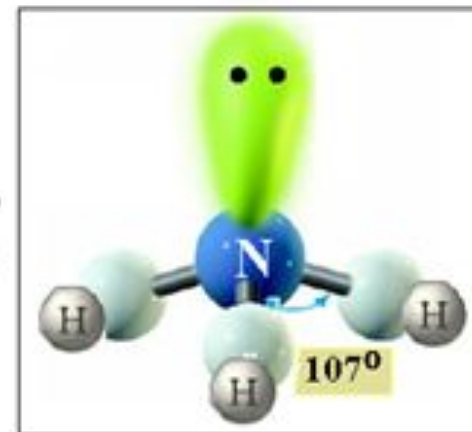
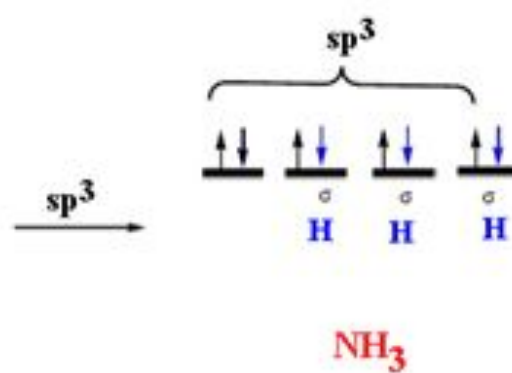
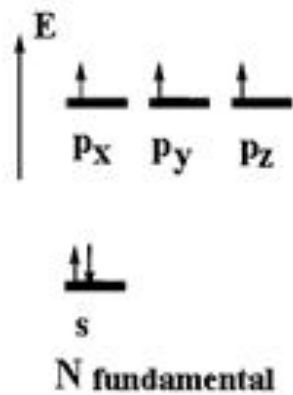
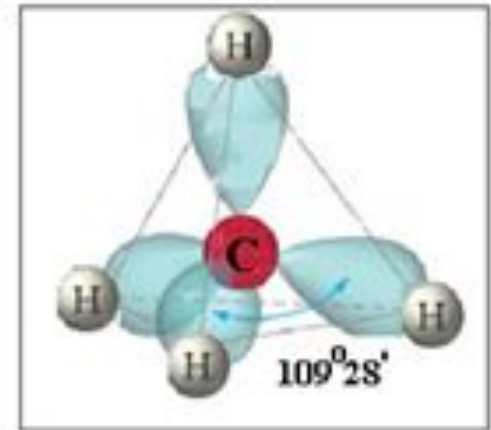
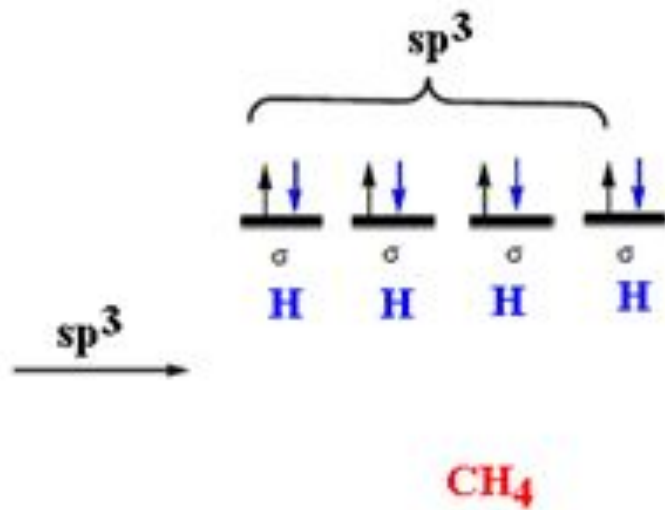
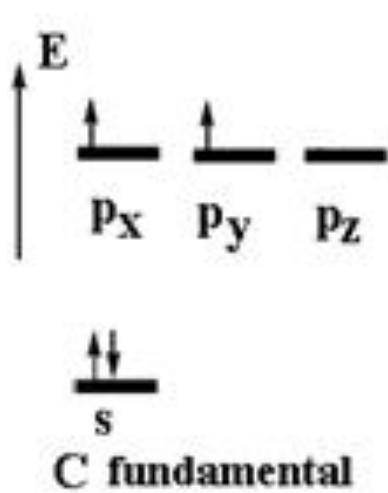



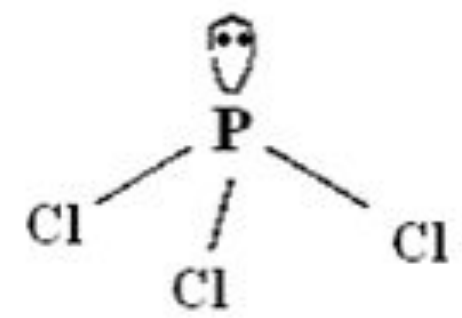
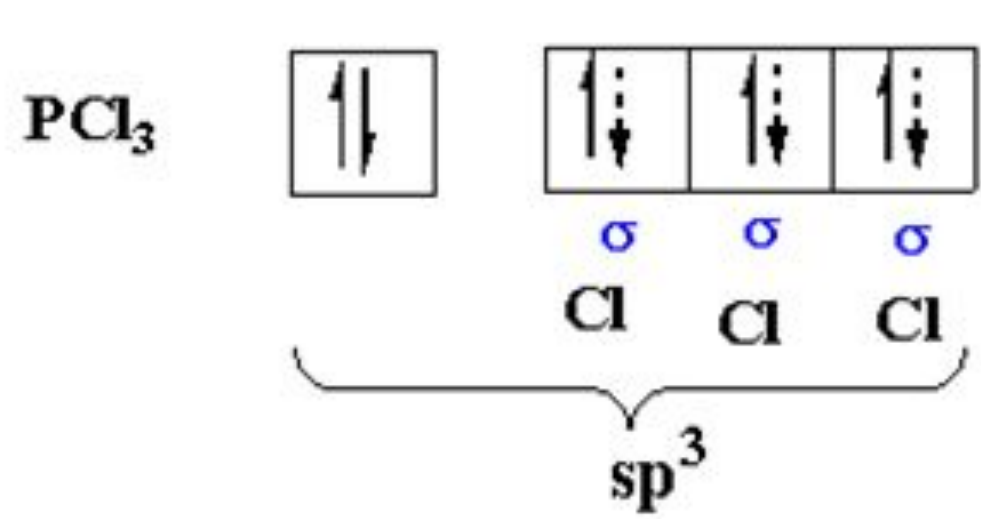
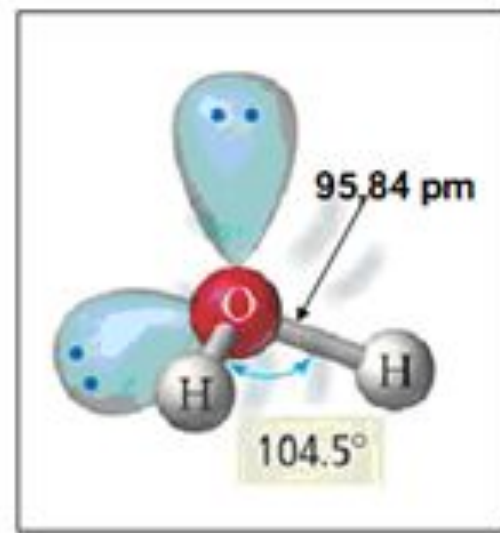
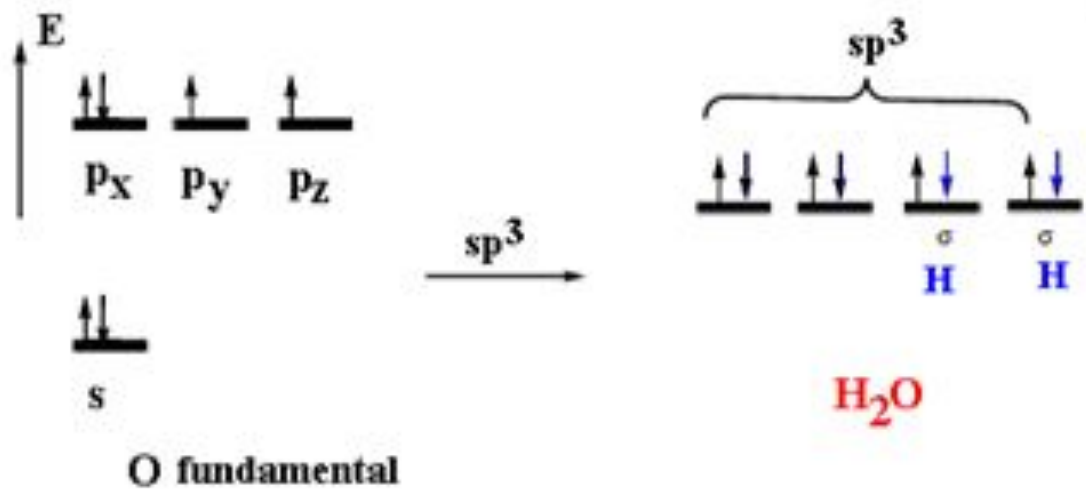



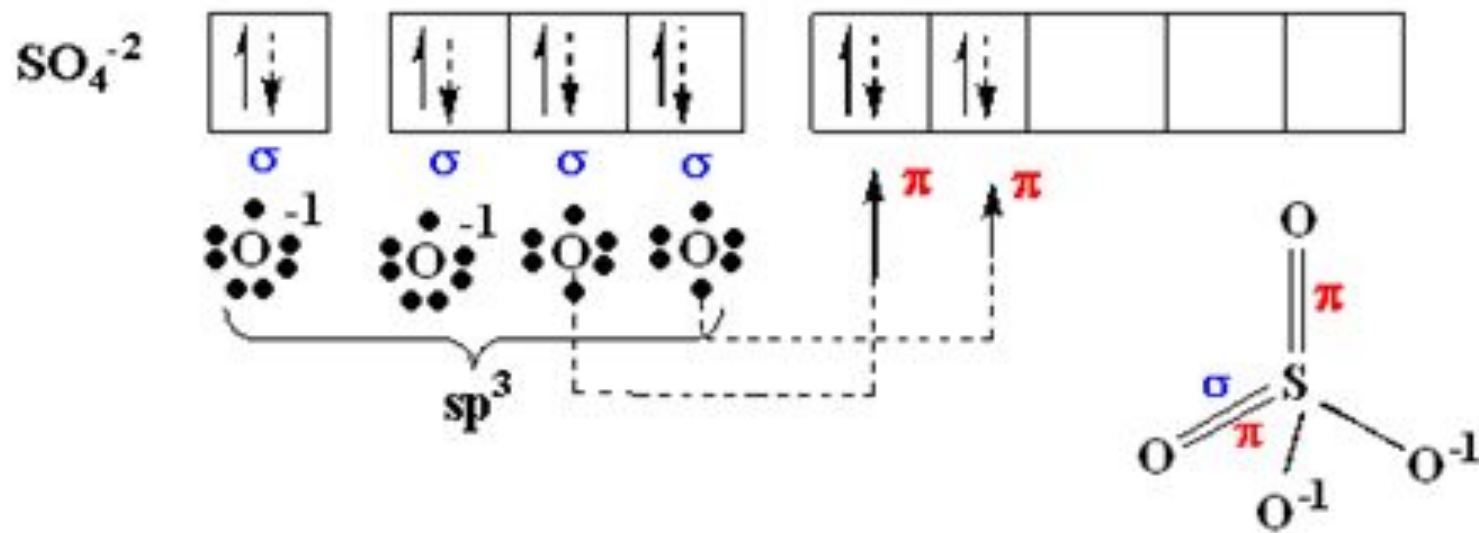
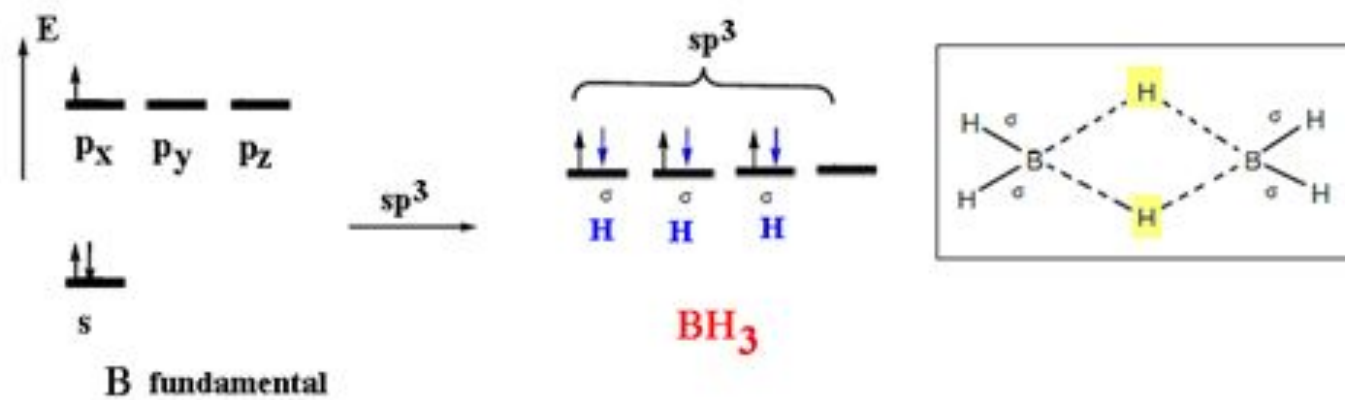

Aplicație: Determinați geometria și hibridizarea în:  $ClO_4^{-1}$ ,  $PO_4^{-3}$ .

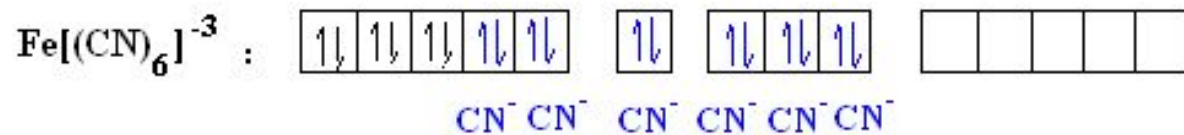
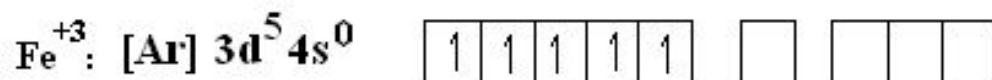
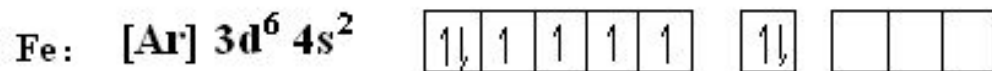

**d<sup>2</sup>sp<sup>3</sup>**

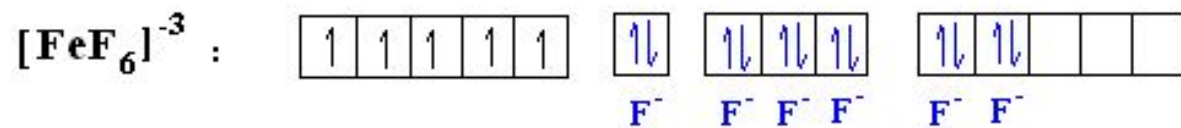

**sp<sup>3</sup>d<sup>2</sup>**

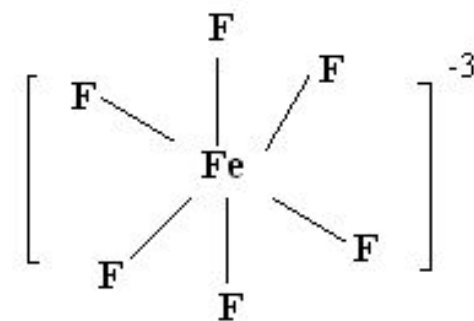
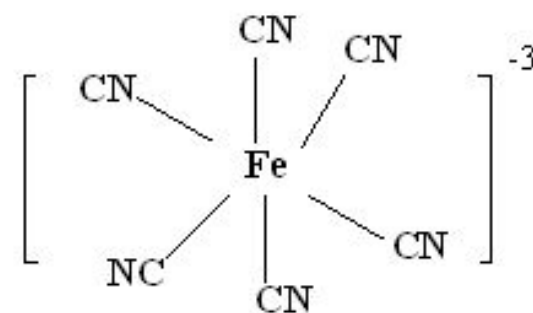

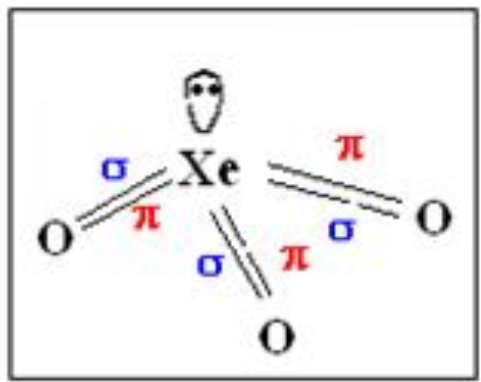
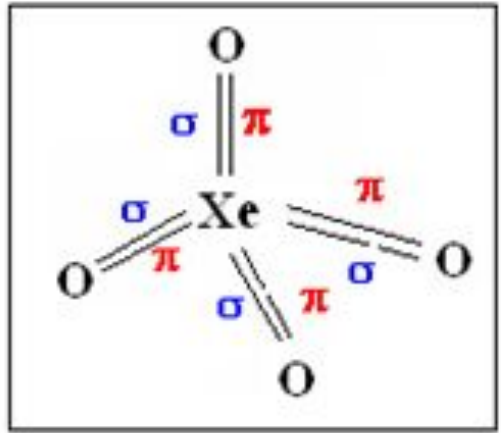
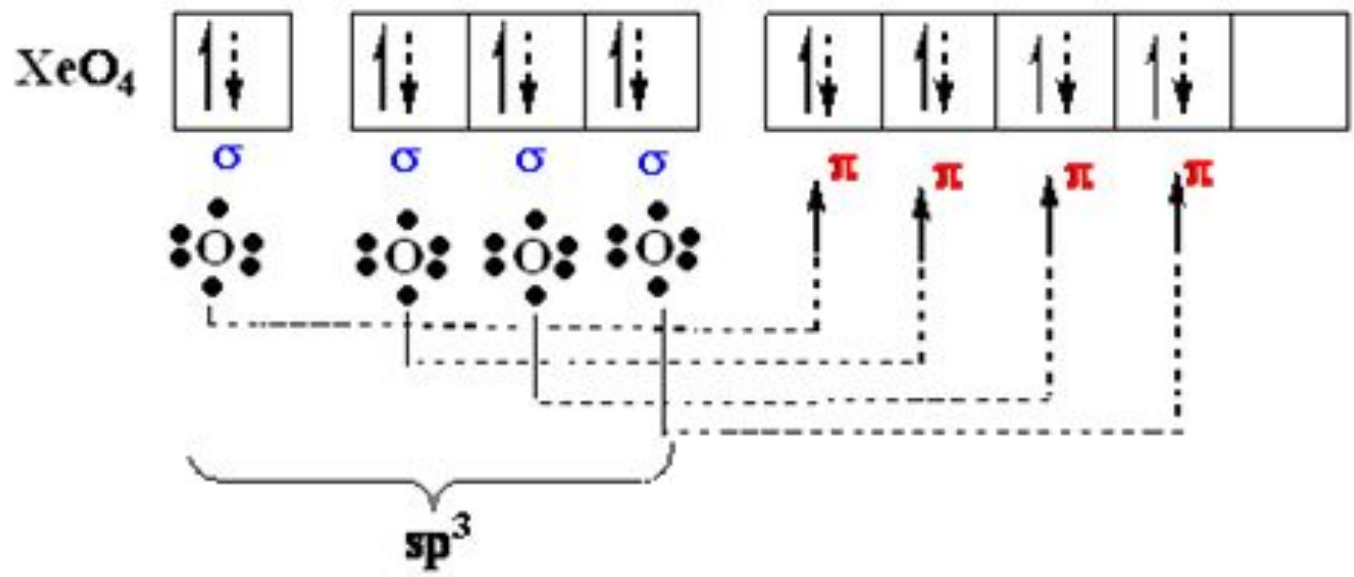

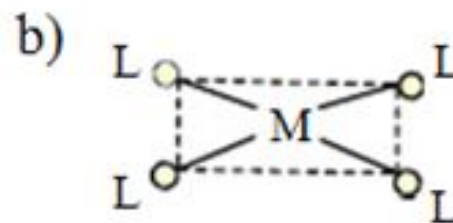
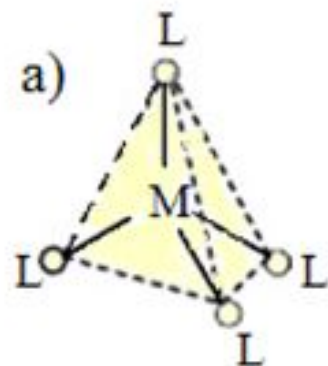

Geometrii caracteristice N.C.=4  
a) tetraedru; b) geometrie plan-pătrată

|

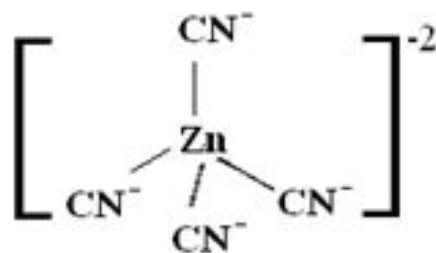
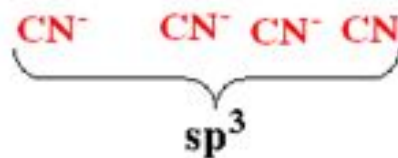
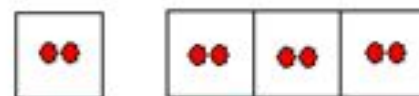
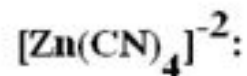
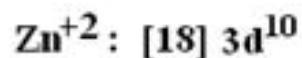
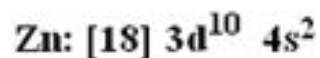

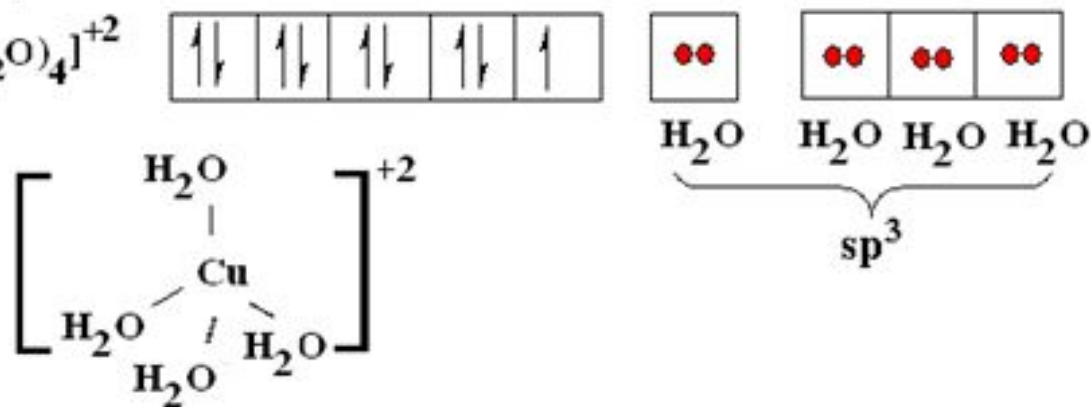
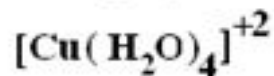
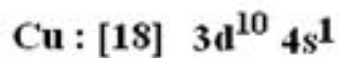
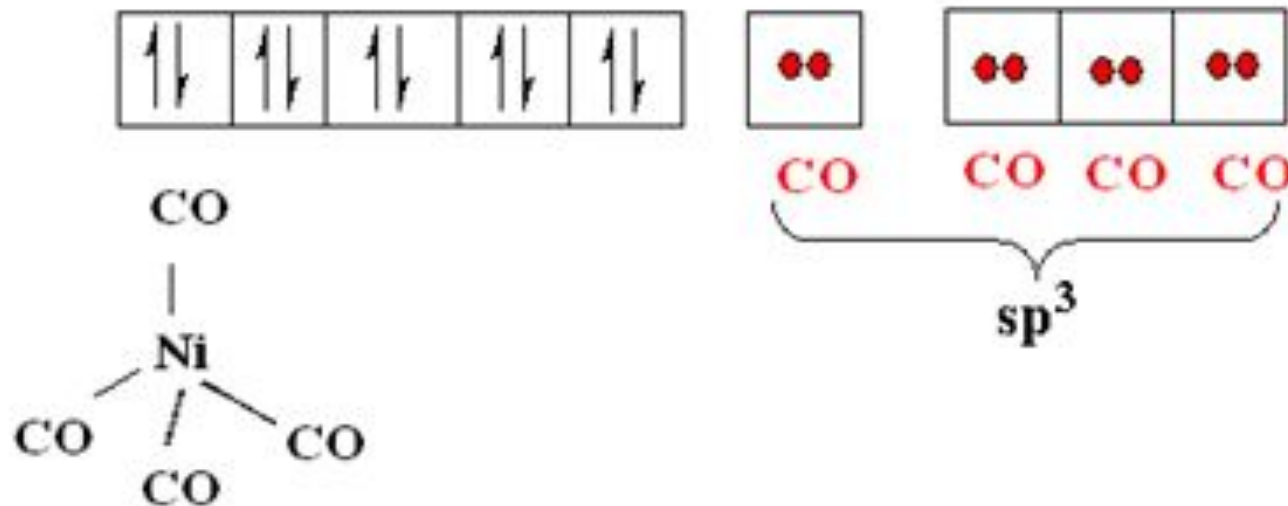
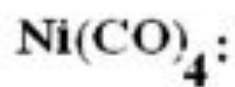
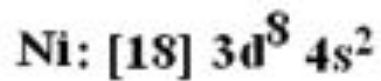

# Hibridizare $d^3s$

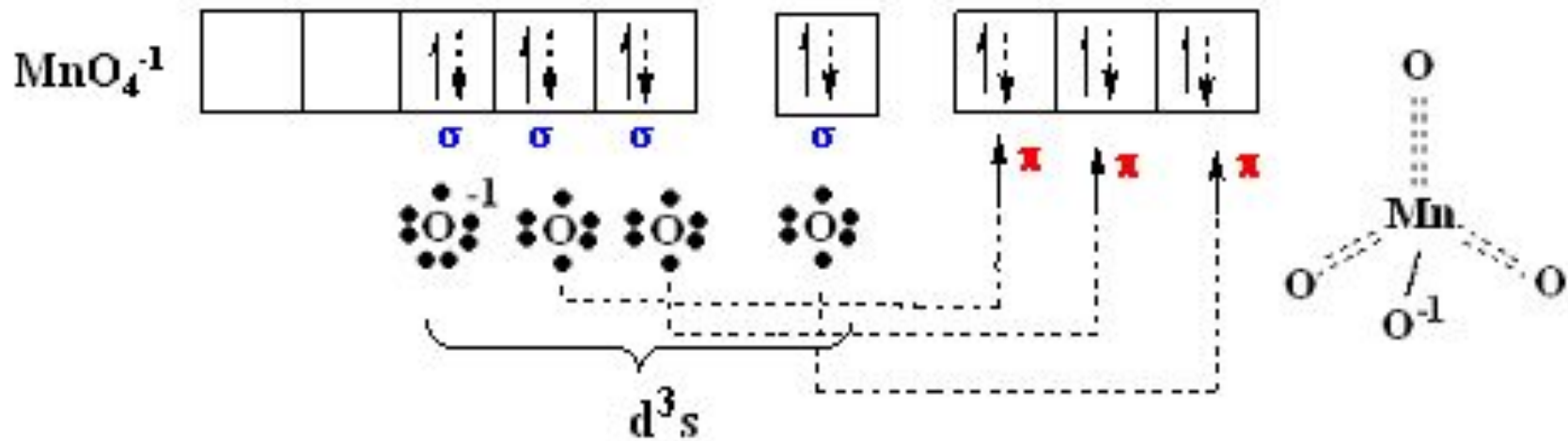
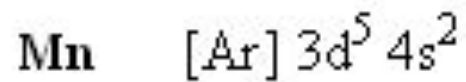

Aplicație: Determinați geometria și hibridizarea în:  $CrO_4^{-2}$ ,  $VO_4^{-3}$ .

# Hibridizare $sp^3d$

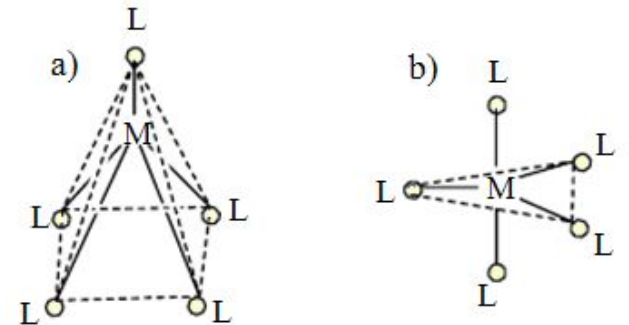
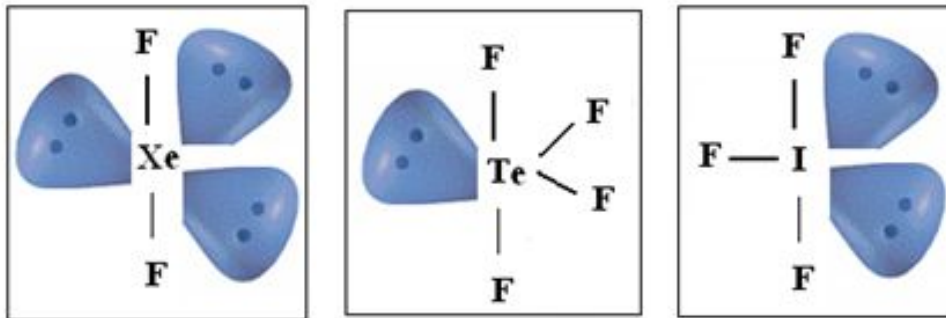
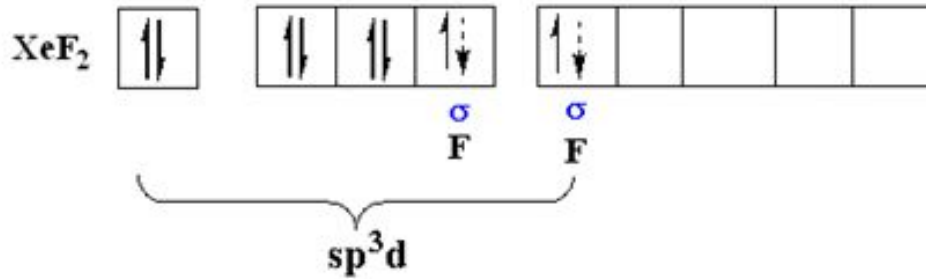
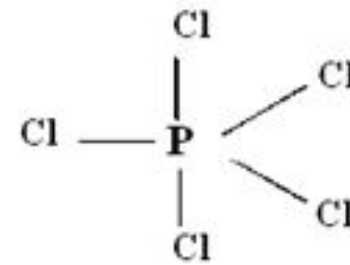
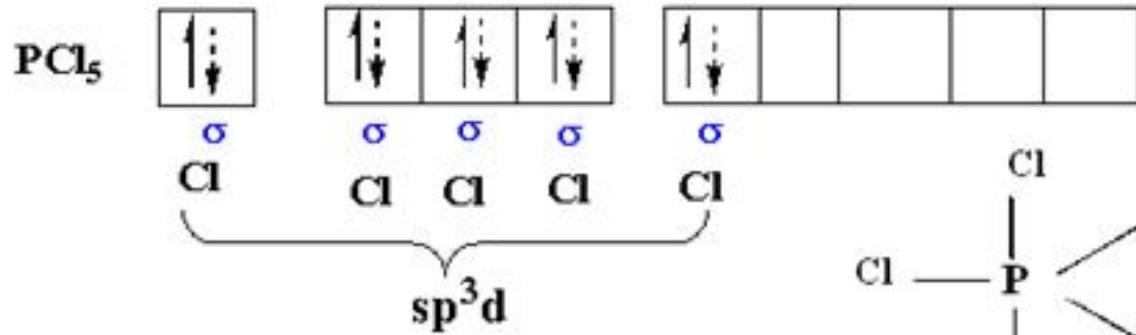

Geometrii caracteristice N.C.=5  
a) piramidă tetragonală; b) bipiramidă trigonală

Aplicație: Determinați geometria și hibridizarea în: XeF<sub>2</sub>, TeF<sub>4</sub>, IF<sub>3</sub>.



# Hibridizare $sp^3d^2$ și $d^2sp^3$

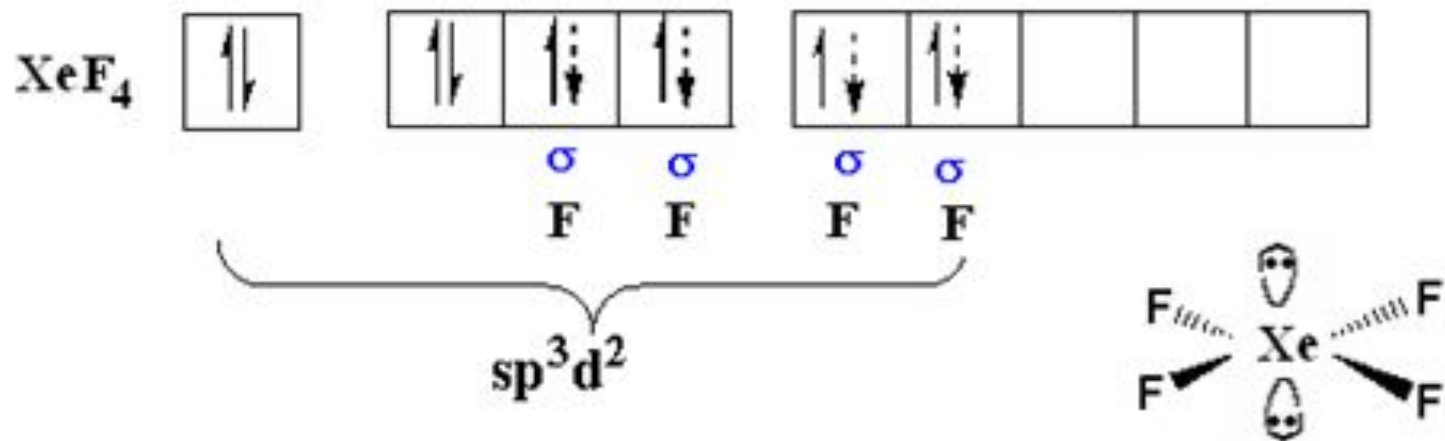
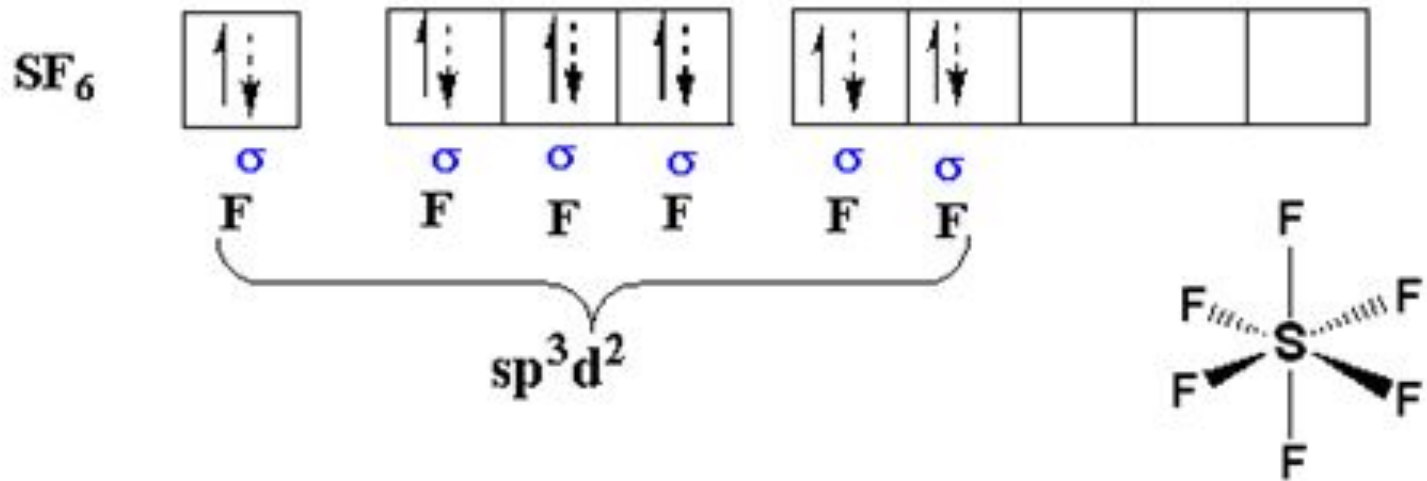

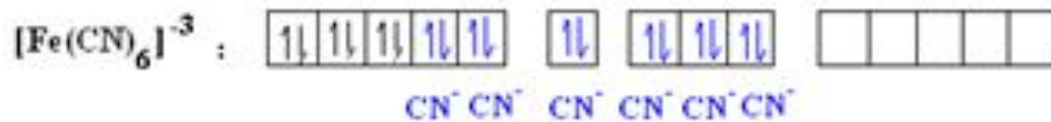
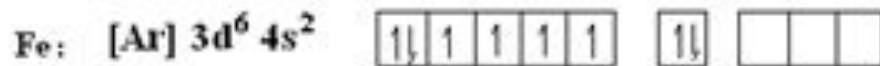

- complex de sferă interioară
- proprietăți diamagnetice

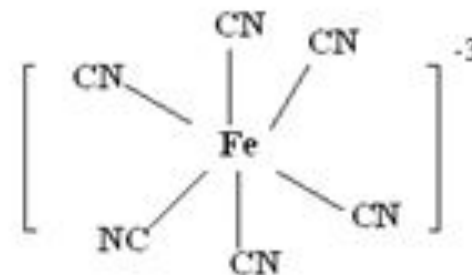

- complex de sferă exterioară
- proprietăți paramagnetice

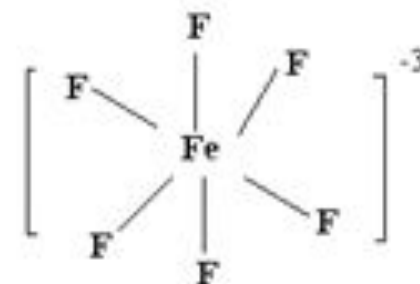

# Hibridizare $sp^3d^3$

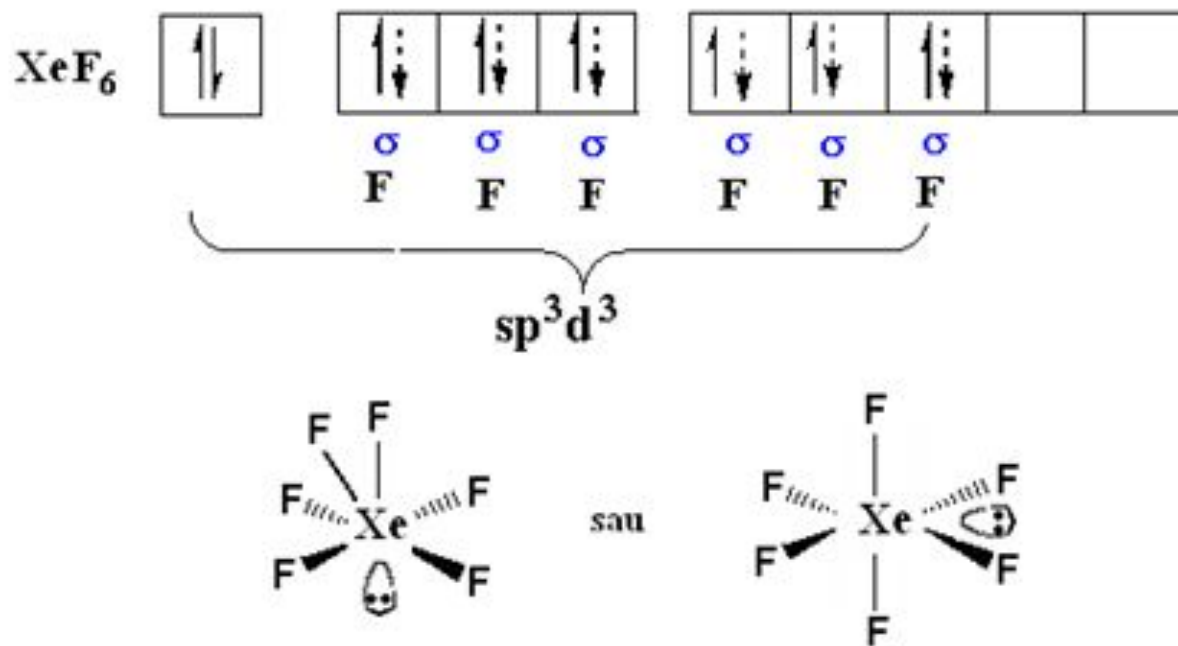
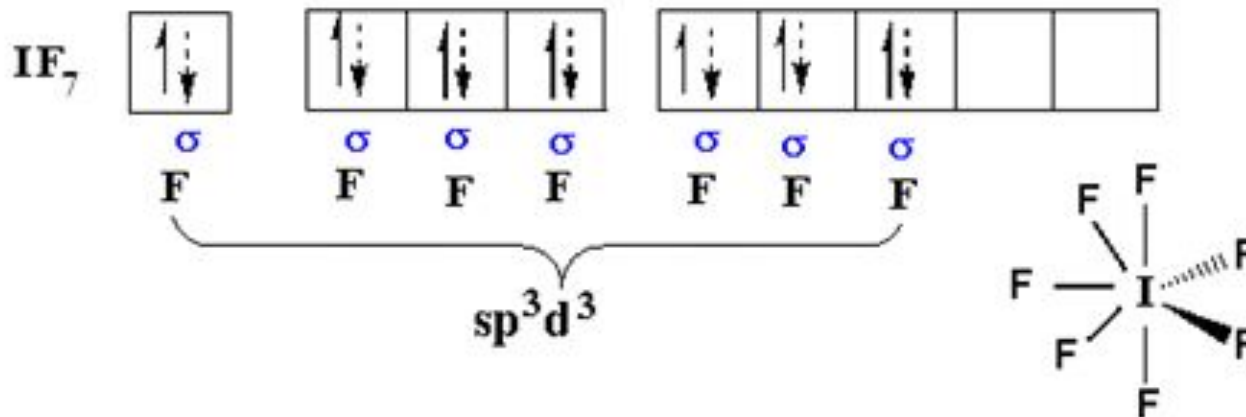

## Aplicații:

1. Determinați hibridizarea și geometria în următorii compuși:

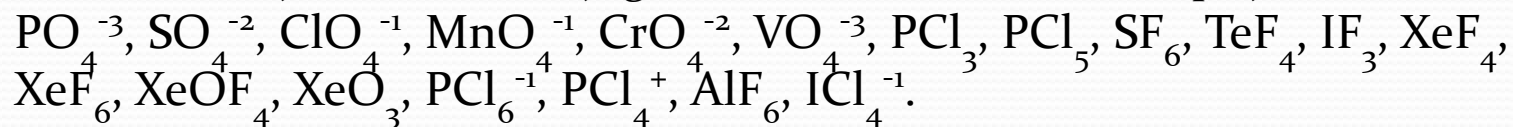

2. Modelați formarea legăturilor ionice din următorii compuși:



3. Modelați formarea legăturilor covalente în următoarele molecule:



4. Determinați hibridizarea și geometria în următorii compuși:

